

Instruction Sheet

Model MCATV56KB4



Customer Service Dept
2245 Delany Rd
Waukegan, IL 60087

Ph: 847/244-1800 • 800/323-4656
Fax: 847/244-1818 • 800/327-1698

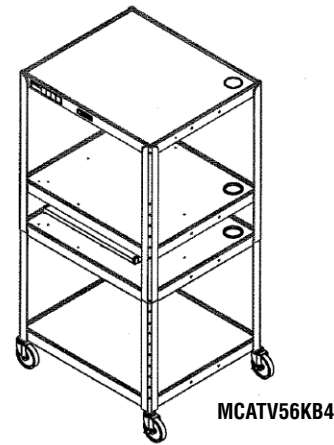

- PARTS LIST FOR KEYBOARD ASSEMBLY**
- 4 - L-brackets
 - 4 - Washers
 - 4 - Bolts
 - 4 - Nuts
 - 4 - Self tapping screws
 - 16 - Sheet metal screws
 - 2 - Runners
 - 1- Keyboard Shelf Rack

- PARTS LIST FOR CART ASSEMBLY**
- 1 - Bottom shelf assembly
 - 4 - Shelf supports
 - 12 - Bolts
 - 12 - Nuts
 - 1 - Top shelf
 - 1 - Middle shelf
 - 4 - Casters two with brake
 - 1- Rubber mat

Step 1

MOUSE SHELF ASSEMBLY

(Note: For the mouse shelf to pull out to the right, use the first set of holes on the left side and the third set of holes from the left. To pull out to left use first set of holes on right and third set of holes from right.)

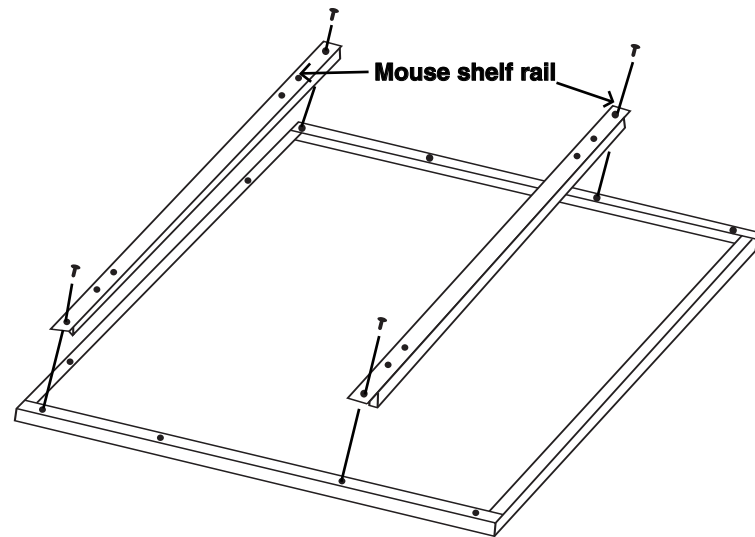

Attach the mouse shelf support bars to the first holes and third holes on the bottom of the keyboard shelf with 4-sheet screws. Then align the brackets on the mouse shelf to the holes on the support bars and attach using 8 sheet metal screws.

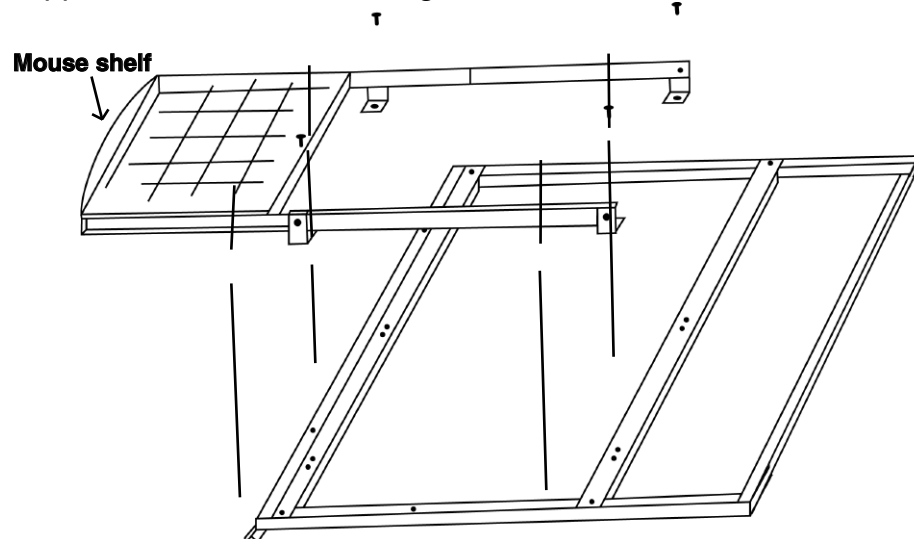

Step 2

Mount the four L-Brackets to the holes on the under side of the middle shelf using 4- bolts, 4- washers and 4- nuts (shelf can be mounted to pull out the side or the front, see diagram below). Be sure brackets are pointing outward. Then align the two threaded holes on the side of the runners to the hole on the brackets and attach with two pan head screws. Do the same to the other side.

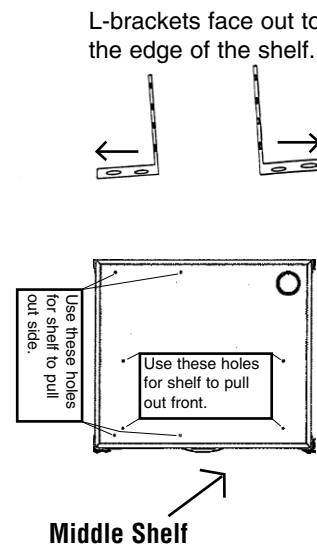

Step 3

Extend runners outward and align the holes on the side of the keyboard shelf to the first hole and last hole on the slides, and attach with two sheet metal screws on each side.

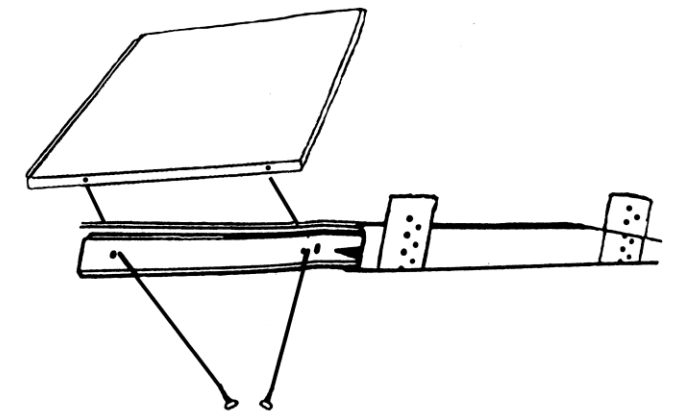

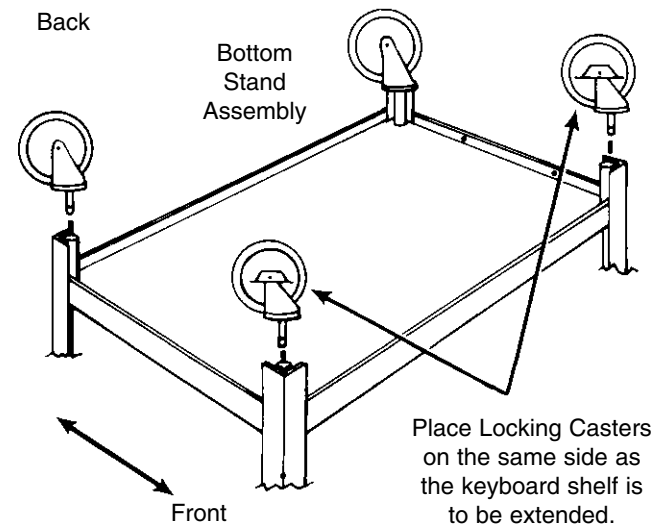

Step 4

Turn bottom stand assembly upside down on a smooth surface. Push the four casters firmly into the caster socket holes in bottom of each leg, as illustrated.

IMPORTANT: Casters must be fully seated. Tap firmly with a rubber mallet properly seat casters. Turn the bottom stand right side up.

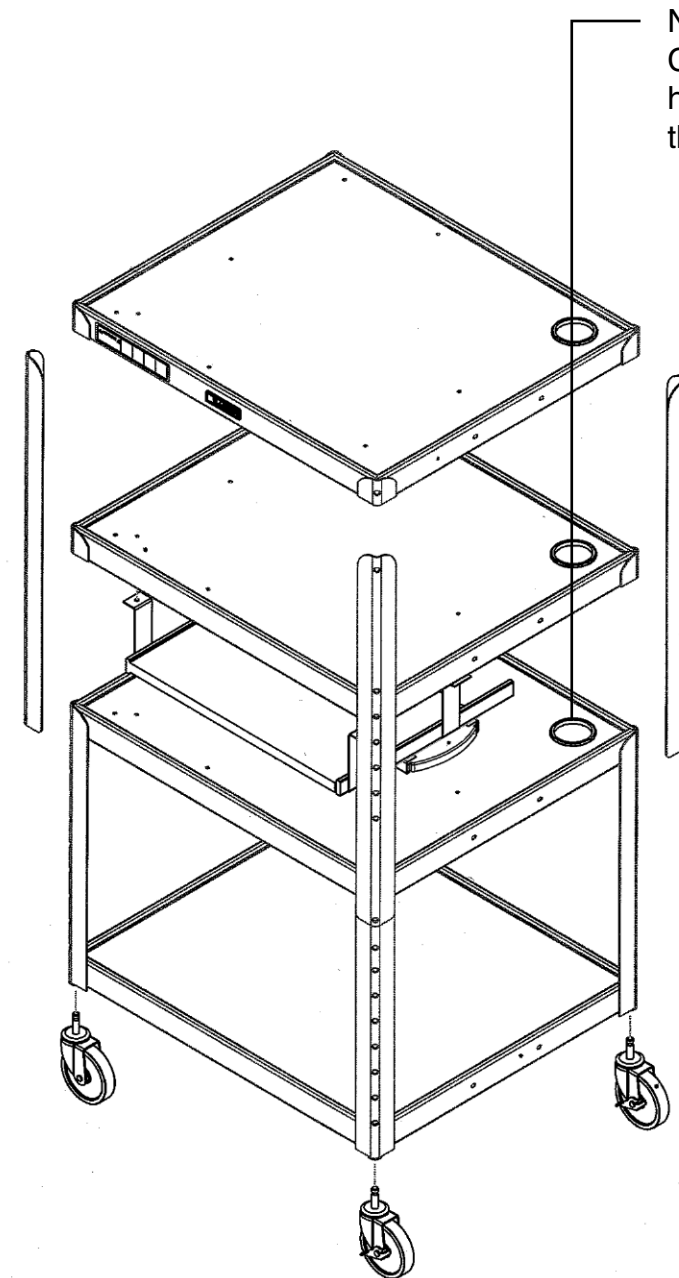

Note:
Cable pass through holes should all be in the same corner.

Step 5

Attach shelf supports to lower assembly at desired height using bolts and wing nuts. Attach middle shelf (with keyboard and mouse shelf) at desired height on shelf supports using 4 bolts and 4 nuts. Attach top shelf at the top of the shelf supports using 4 bolts and 4 nuts. Place rubber mat on top shelf, align hole in mat with cable pass through hole on shelf.

Note:
Put printer cable through the cable pass through holes first, it may not fit if other cables have already been placed through holes.