

Instruction Sheet

MMC56

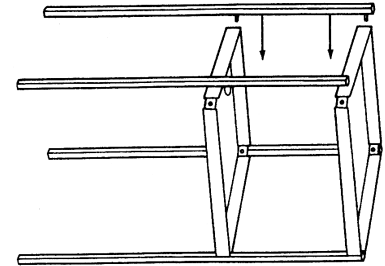

Customer service dept.
2245 Delany Rd
Waukegan, IL 60087
Ph: 847/244-1800 • 800/323-4656
Fax: 847/244-1818 • 800/327-1698

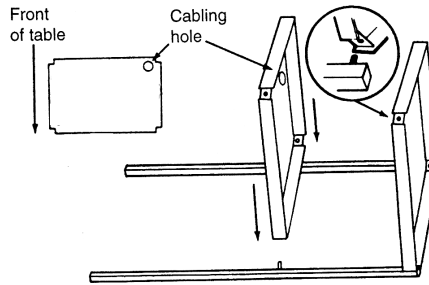
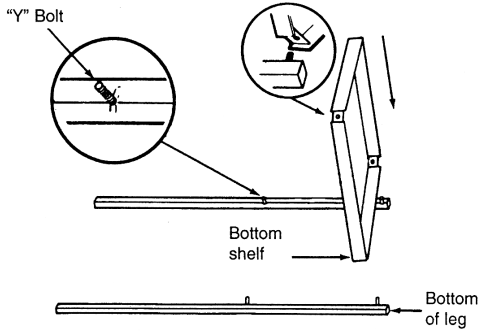

1. Lay two legs on flat surface as illustrated. Note: "Y" bolts on legs must all face inward and upward. The two holes in each leg must face toward each other on the short side of the table as shown. Locate the bottom shelf. It is the only shelf without a cabling hole.

2. Insert "Y" bolts that are welded to the bottom of the legs, into corners of the shortest side of bottom shelf with the two small holes, in shelf surface toward the front of table. Screw on keep nuts and finger tighten only. Locate center shelf with cable hole only. Position shortest side of shelf onto "Y" bolts on legs in the same manner as done with the bottom shelf. Screw on keep nuts and finger tighten.

3. Place the two remaining legs into the shelf corners of middle and bottom shelves. Screw on keep nuts and finger tighten.

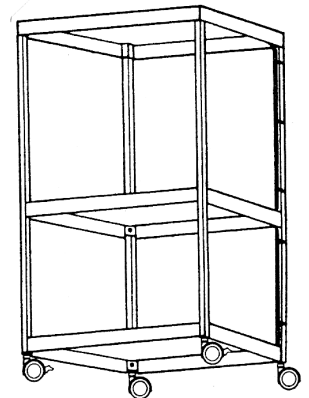
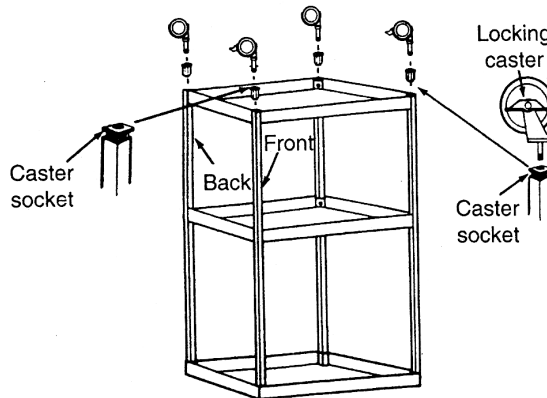
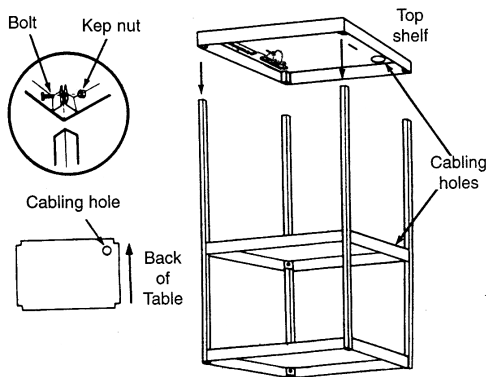

4. Turn table right side up and push top shelf onto the four legs. Important: Tap firmly with rubber mallet until completely seated. Insert hex head bolt in each corner leg bracket on the underside of top shelf as illustrated. Screw on keep nuts. Now tighten all nuts with wrench provided.

5. Turn table bottom side up and install caster sockets. Use rubber mallet to tap caster sockets into bottom of all four legs. Important: Casters must be fully seated. Tap firmly with rubber mallet to properly seat casters. Be certain to keep locking casters facing the front on the widest side of the table as illustrated.

6. Turn cart onto casters for remaining assembly.

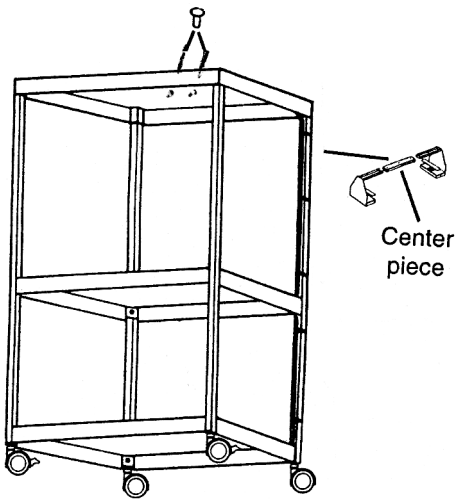

7. Starting from the top shelf, first attach VCR holder center piece to the top shelf using 2- $\frac{3}{4}$ " screws and 2- rubber washers (don't fully tighten) supplied with VCR bracket. Then insert VCR holder extension arms and fully tighten.

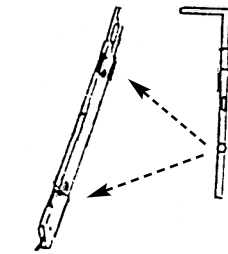

8. Attach 5" and 10" brackets to the 2 threaded holes on the side of the runners with the screws provided.

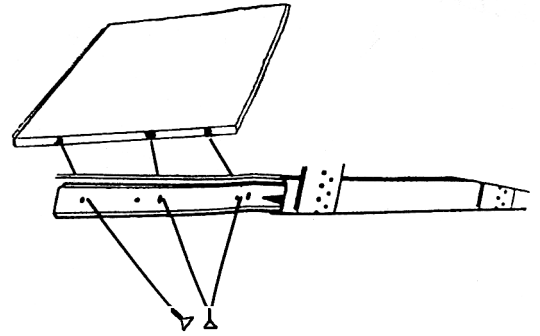

9. Extend the slides out from the runners and align the holes on the sides of the keyboards to the holes on the slides. Attach with sheet metal screws provided.

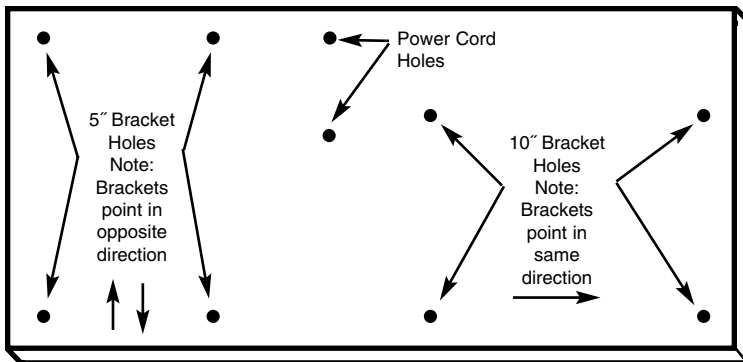

Top View of Middle Shelf

10. Once the keyboard, runners, and brackets are assembled, align the holes on the top of the brackets to the holes on the middle shelf and attach with 4 - $\frac{1}{2}$ " bolts and 4 nuts.

12. Insert one CPU holder into single hole and one into slotted holes. Tighten with wing nuts supplied.



Top View of Bottom Shelf

Power Assembly

11. Insert 2- $\frac{1}{2}$ " sheet metal screws into pre-drilled holes $\frac{3}{4}$ of the way in. Slide the back of the power assembly onto screws and lock into place.