

Instruction Sheet Model PC42KB



Customer Service Dept
2245 Delany Rd • Waukegan, IL 60087
Ph: 847/244-1800 • 800/323-4656
Fax: 847/244-1818 • 800/327-1698



PC42KB

Parts List

- 1 - Top shelf w/handle
- 1 - Middle shelf w/8 leg posts
- 1 - Bottom shelf w/caster sockets
- 1 - Set short legs
- 1 - Set long legs
- 5 - Casters (2 w/brake)
- 1 - Electric assembly
- 1 - Cord wrap
- 2 - Keyboard assemblies

Tools Required:
Rubber mallet

Illustration A

1. The electric unit should be assembled first. Cord wrap must be installed on leg before assembly of complete unit. See below.

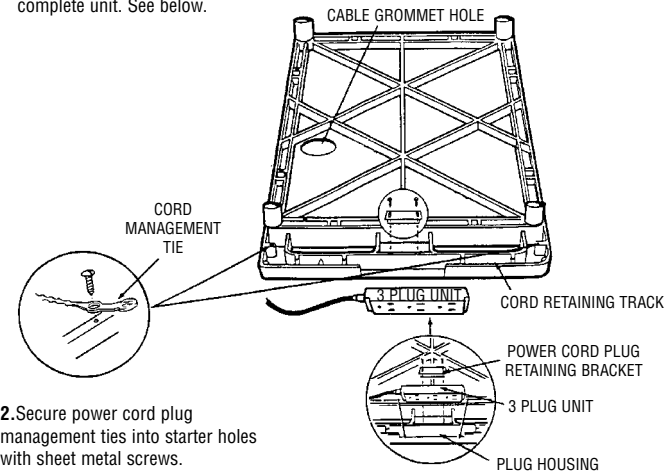

2. Secure power cord plug management ties into starter holes with sheet metal screws.

3. Firmly seat electric assembly 3 plug unit into handle plug housing as illustrated. Secure with power cord plug retaining bracket.

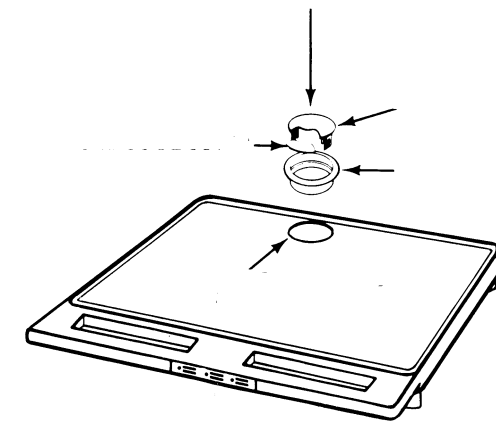

1. Install grommet ring by tapping into place with rubber mallet. Insert grommet cap as illustrated. For tables with electric assembly, snap off cord guide cover from grommet cap so equipment plug may be run through grommet plug unit, then insert grommet cap into grommet ring.

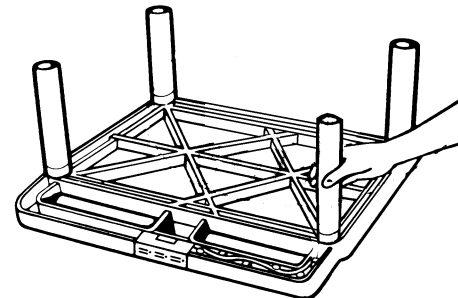

2. Lay top shelf (with handle) ribbed side up on a smooth surface. Push all 4 short legs onto leg posts.

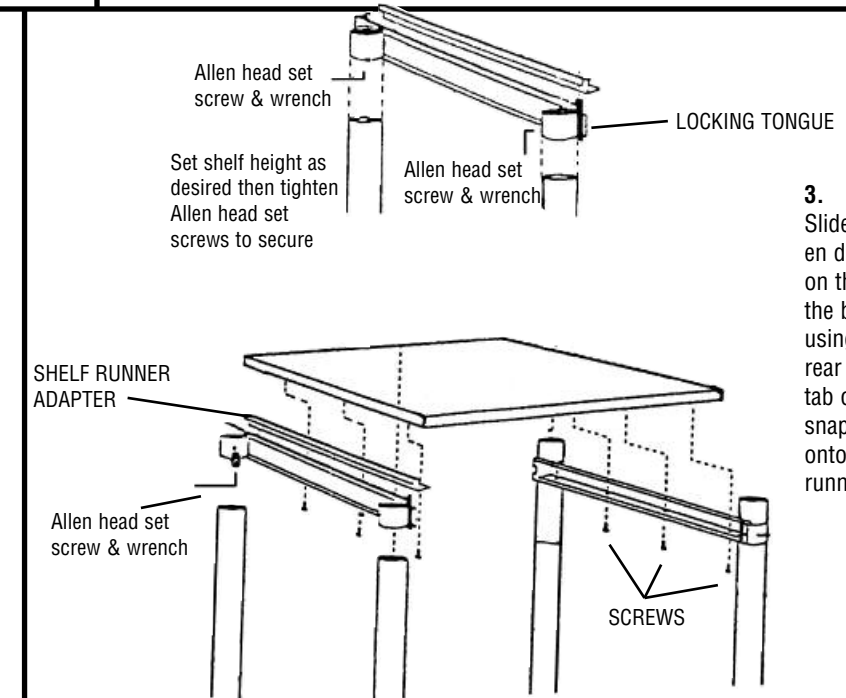

Set shelf height as desired then tighten Allen head set screws to secure

3. Slide runners onto the legs and tighten down to desired height. Align holes on the shelf adapters to the holes on the bottom of the keyboard and attach using six sheet metal screws. Slide the rear of the shelf adapters under the tab on the back of the runners and snap the front of the shelf adapters onto the back tongue on the front of runners.

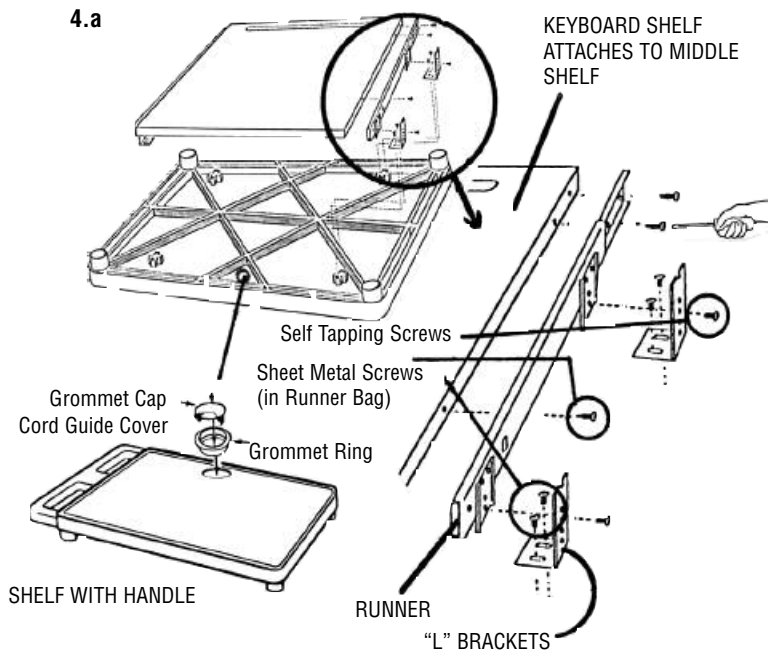

KEYBOARD SHELF ATTACHES TO MIDDLE SHELF

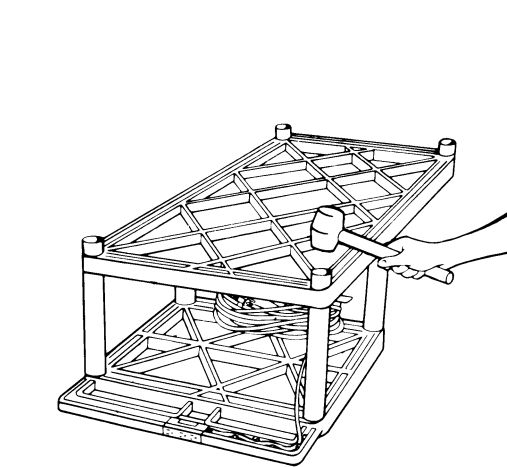

4. Position second shelf (with 8 leg posts) ribbed side up, over the 4 legs and insert leg posts into legs. Using a rubber mallet, firmly hammer bottom shelf into legs until all four legs are seated (flush) against the surfaces of both shelves. Attach keyboard (see step 4.a)

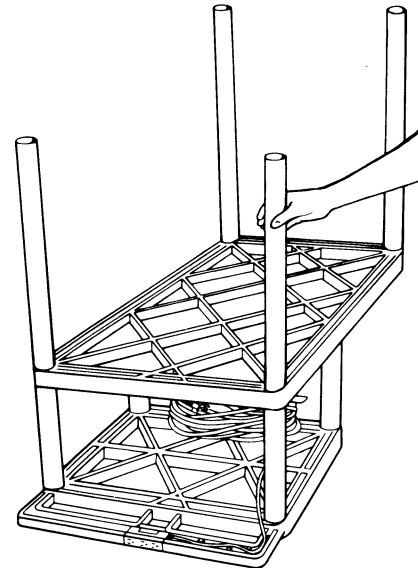

5. Push set of 4 long legs into leg posts of second shelf and firmly hammer until properly seated.

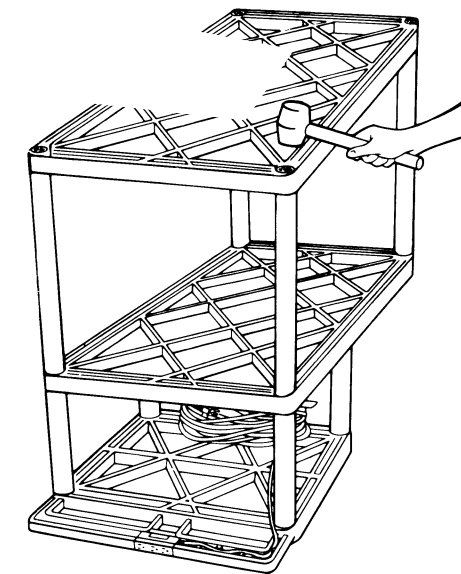

6. Position bottom shelf, ribbed side up, over the 4 long legs and insert leg posts into legs. Using a rubber mallet, firmly hammer bottom shelf into legs until all four legs are seated (flush) against the surfaces of both shelves.

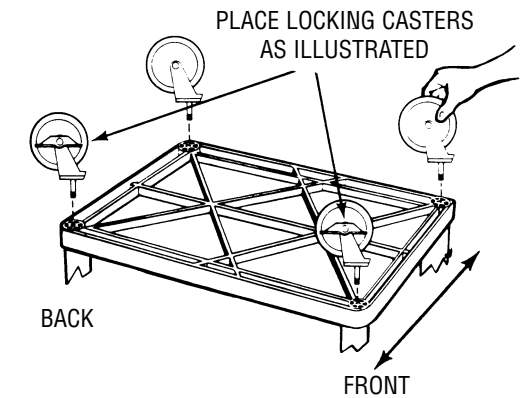

7. Push the four casters firmly into the holes in each corner of the bottom shelf. **Important:** casters must be fully seated. Tap firmly with rubber mallet to properly seat casters. Turn your table right side up. It is now ready for use.

Parts List