

Instruction Sheet

Endura Models PC44KBC



Customer Service Dept.
2245 Delany Road
Waukegan, IL 60087
Ph: 847/244-1800 • 800/323-4656
Fax: 847/244-1818 • 800/327-1698



PC44KBC

PARTS LIST

- | | |
|--------------------------------|--|
| 1 - Top Shelf | 4 - Self Tapping Screws (in Runner Pkg.) |
| 1 - Middle Shelves | 6 - 5/8" screws |
| 1 - Bottom Shelf | 14- Sheet Metal Screws (in Runner Pkg.) |
| 1 - Keyboard Shelf | 1 - Cabinet pack assembly |
| 2 - Runners | |
| 4 - "L" Brackets | |
| 1 - Power Cord-Surge Protected | |
| 8 - Legs | TOOLS REQUIRED: |
| 2 - Casters | 1 - Rubber Mallet (included) |
| 2 - Casters w/Brake | 1 - Slotted Screwdriver |
| | 1 - Phillips Screwdriver |

1

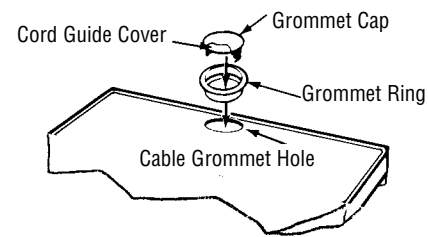

2

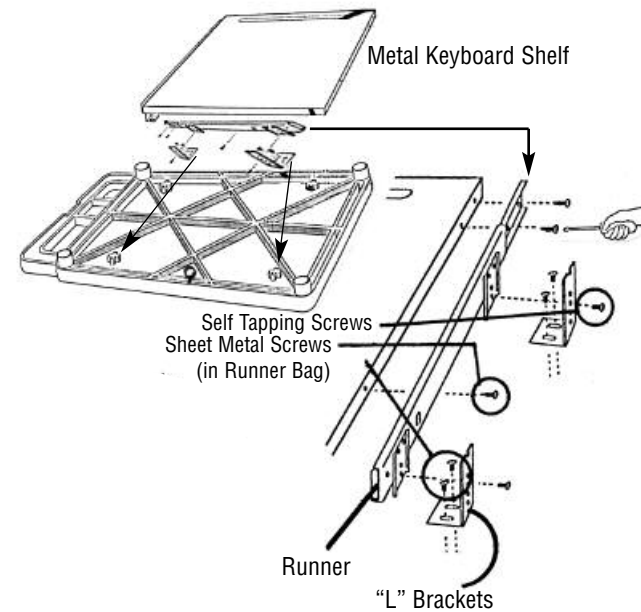

3

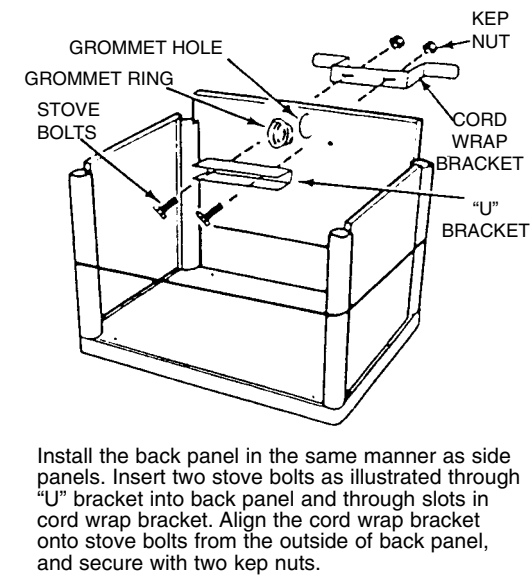

3

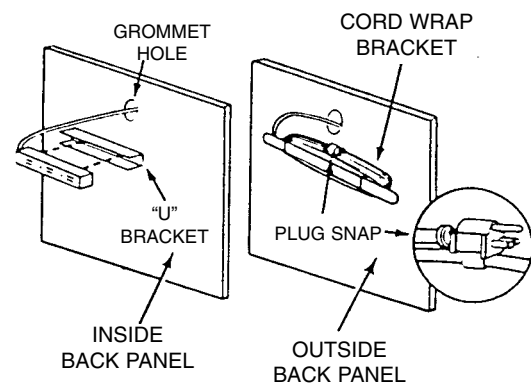

4

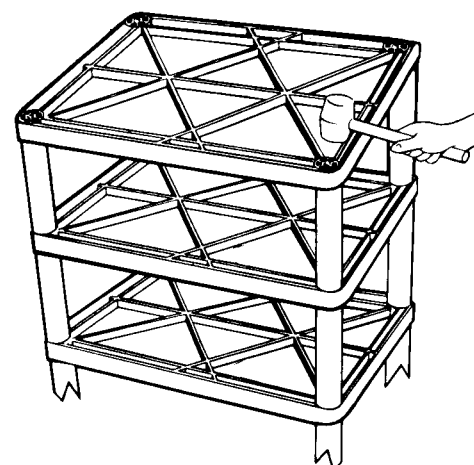

5

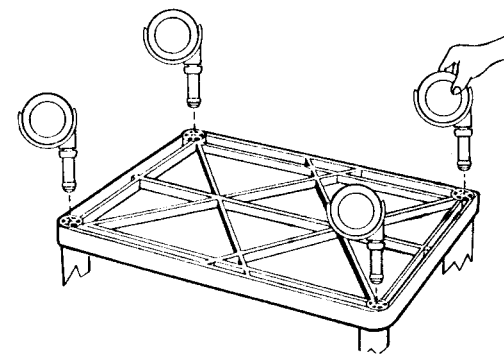

1. Install grommet ring into gromet hole on top shelf.
- 2A. To install metal pull-out shelf, first turn workstation middle shelf upside down, locate the four "L" bracket support members as shown in step 1.
- 2B. Secure "L" brackets to "L" bracket support members using two 5/8 sheet metal screws per bracket. Do not fully tighten screws at this time. **Note:** "L" brackets must face each other pointing in towards center of workstation shelf.
- 2C. Next, identify left runner from right runner. This is done by extending runner fully to locate the three holes used to attach to metal shelf. The portion of the runner with holes must face toward front of metal shelf. Turn metal shelf upside down and install runners on each side using three sheet metal screws on each side. **Note:** Remember all assembly is being done upside down. Position assembled shelf and runner between "L" brackets to determine proper spacing of "L" brackets. Carefully remove metal shelf and fully tighten "L" brackets.
- 2D. Use self tapping screws to secure runner to "L" brackets. For maximum clearance use hole on "L" bracket that is farthest away from workstation top shelf.
3. Install cabinet pack according to the instructions in the cabinet pack assembly box. Install electric assembly.
4. Turn right side up and install upper legs and top shelf with keyboard.
5. Install casters into each of the four corners. **Important:** Make sure casters are fully seated. Turn cart right side up. Your Endura is ready to use.

Press 3-outlet power cord into "U" bracket and feed remaining cord through grommet hole and wrap remaining cord around cord wrap bracket. For safety and neat appearance, secure cord plug to cord with plug snap.