

# Instruction Sheet - PSLP46



Customer Service Dept  
 2245 Delany Rd  
 Waukegan, IL 60087  
 Ph: 847/244-1800 • 800/323-4656  
 Fax: 847/244-1818 • 800/327-1698



## Parts List

- 1- Bottom shelf w/caster sockets
- 1- Top shelf w/handle
- 1 - Middle shelf
- 8- legs
- 1 - Pull out shelf assembly
- 4- Casters (2 with brakes)
- 1- Electric assembly

- Tools Required:**
- 1- Rubber mallet (supplied)
  - 1- screwdriver

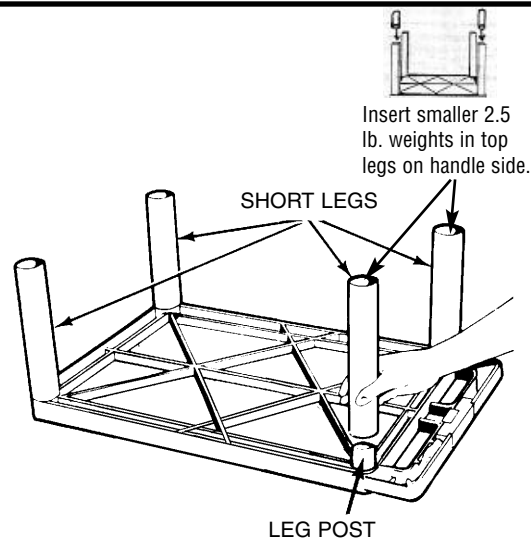

**1.** Install grommet ring and cap as illustrated in Step #1 above. Lay top shelf (with handle) ribbed side up on a smooth surface. Push all **4 short legs** onto leg posts.

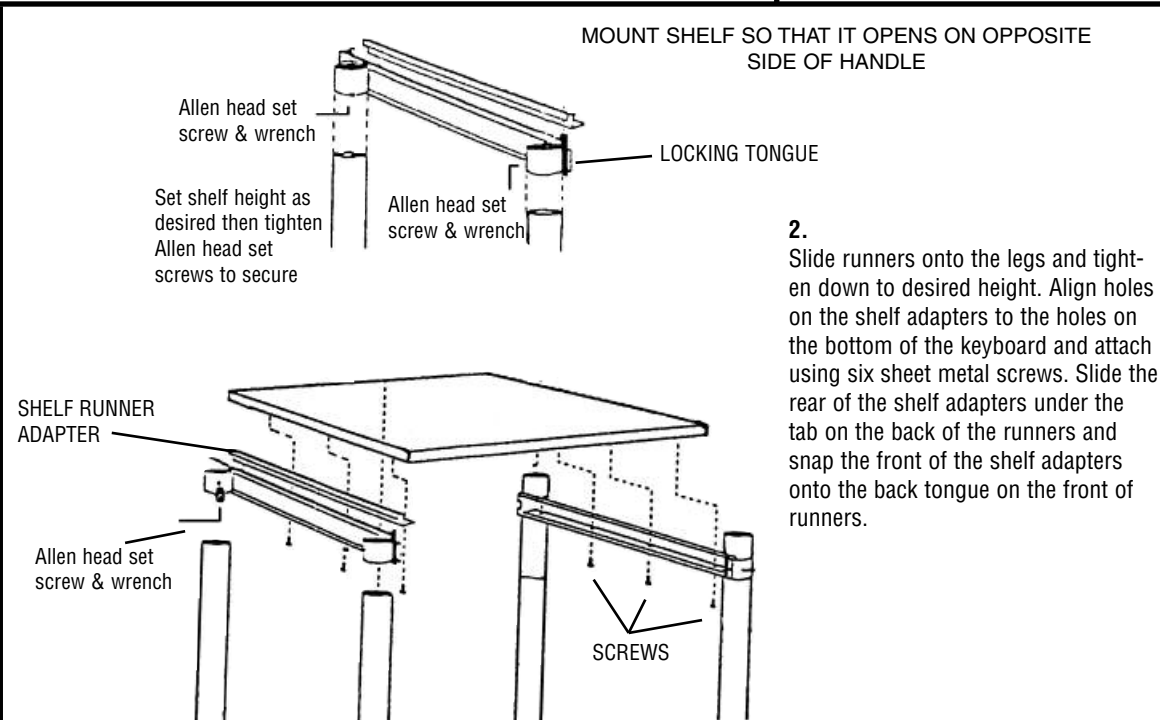

**2.** Slide runners onto the legs and tighten down to desired height. Align holes on the shelf adapters to the holes on the bottom of the keyboard and attach using six sheet metal screws. Slide the rear of the shelf adapters under the tab on the back of the runners and snap the front of the shelf adapters onto the back tongue on the front of runners.

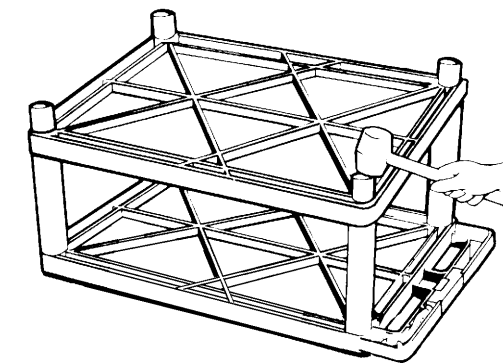

**3.** Position **center shelf** (with **8 leg posts**) ribbed side up over the 4 legs and insert leg posts into **short legs**. Using a rubber mallet, firmly hammer center shelf into legs until all four legs are seated (flush) against the surfaces of both shelves.

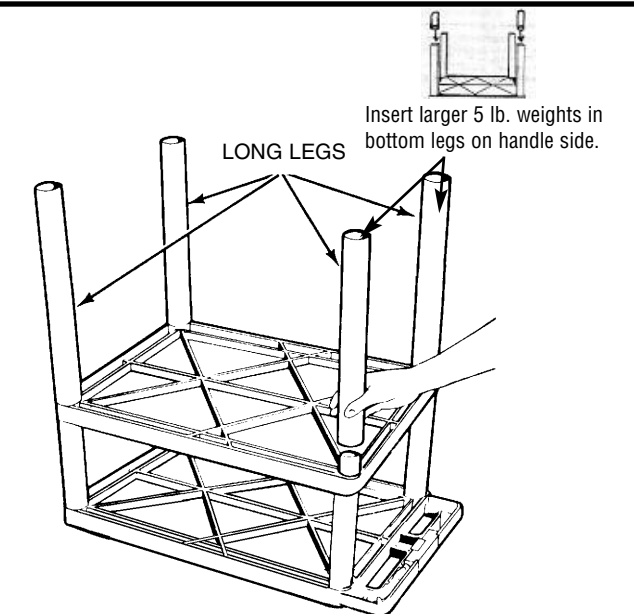

**4.** Push remaining **4 long legs** into leg posts of center shelf.

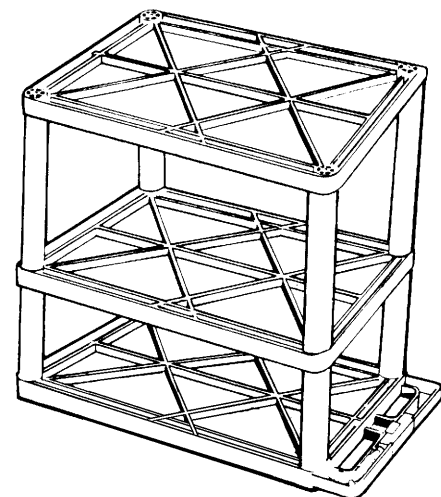

**5.** Position bottom shelf, ribbed side up, over the **4 long legs** and insert leg posts into long legs. Firmly hammer bottom shelf until seated onto all 4 legs.

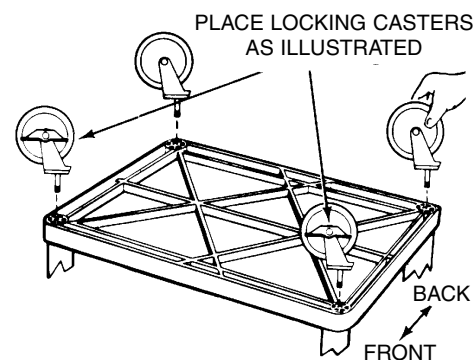

**6.** Push the four casters firmly into the holes in each corner of the bottom shelf. **Important:** Casters must be fully seated. Tap firmly with rubber mallet to properly seat casters. Turn your Endura Table right side up.

# Instructions For - Electrical Assembly Cable-Track™ Management System and Cord Wrap

Your Endura mobile equipment table incorporates the Cable-Track™ cord management system. This exclusive feature manages electrical cords, keeping them safely out of the way. This system includes a 3-outlet, 15 foot surge suppressing electric assembly (U.L. and C.S.A.

listed) which is built into the safety handle. Please review these instructions carefully to maximize the added safety provided by Luxor's Cable-Track™ cord management system.



## Parts List

|                                |                              |
|--------------------------------|------------------------------|
| 1 - Surge protected power cord | 1 - Power cord retainer clip |
| 1 - Cord wrap                  | 2 - "E"-clips                |
| 4 - Cord management ties       | 4 - Sheet metal screws       |

### ILLUSTRATION A

#### Important

1. The electrical unit should be assembled first.

Cord wrap must be installed on leg before assembly of complete unit.  
\*See below (See Illus. B).

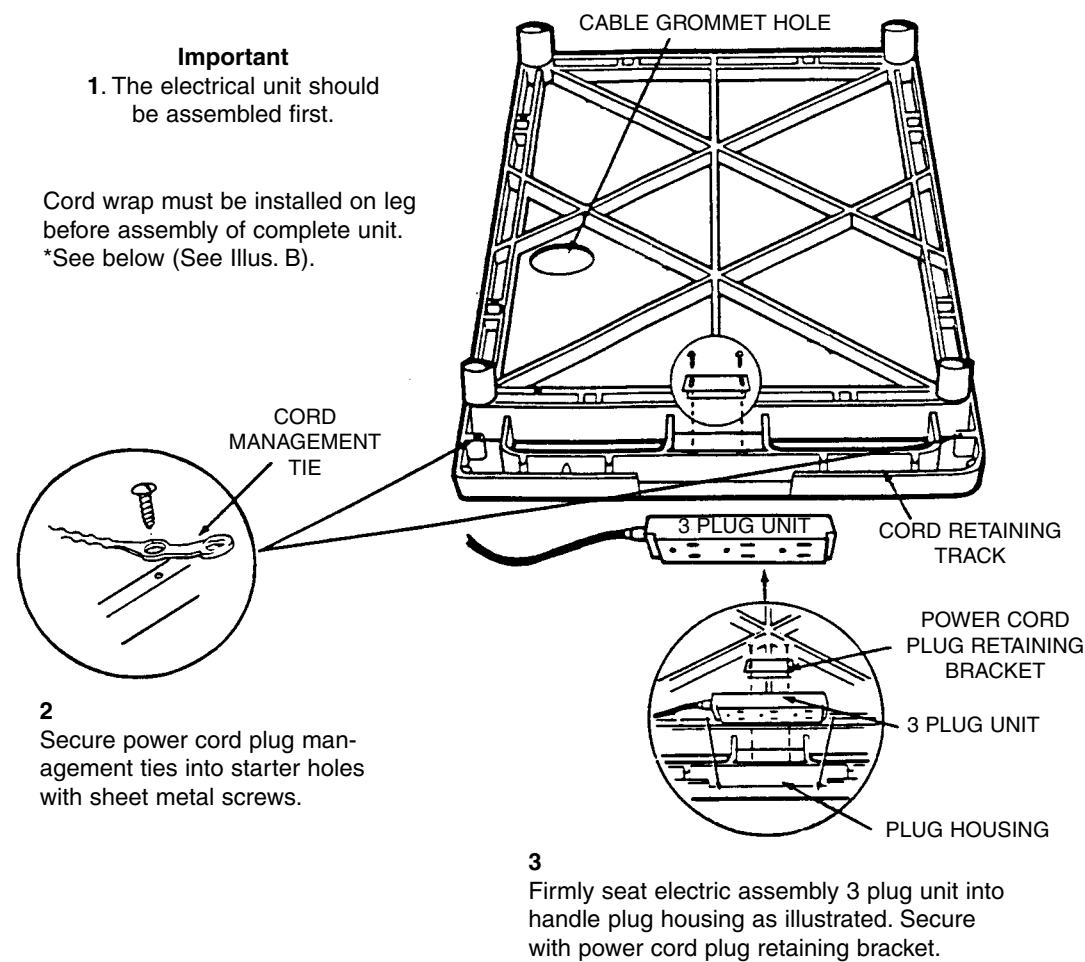

- 2 Secure power cord plug management ties into starter holes with sheet metal screws.

- 3 Firmly seat electric assembly 3 plug unit into handle plug housing as illustrated. Secure with power cord plug retaining bracket.

### ILLUSTRATION B

Install correct size leg on top shelf then slide cord wrap down over leg into position.

- 4 Thread power cord through cord retaining track, secure with cord management ties by wrapping tie around cord and fastening. Cut off any unnecessary extra length of tie. Wrap remaining cord around the cord wrap bracket. For safety and new appearance, secure cord plug to cord by utilizing plug snap.

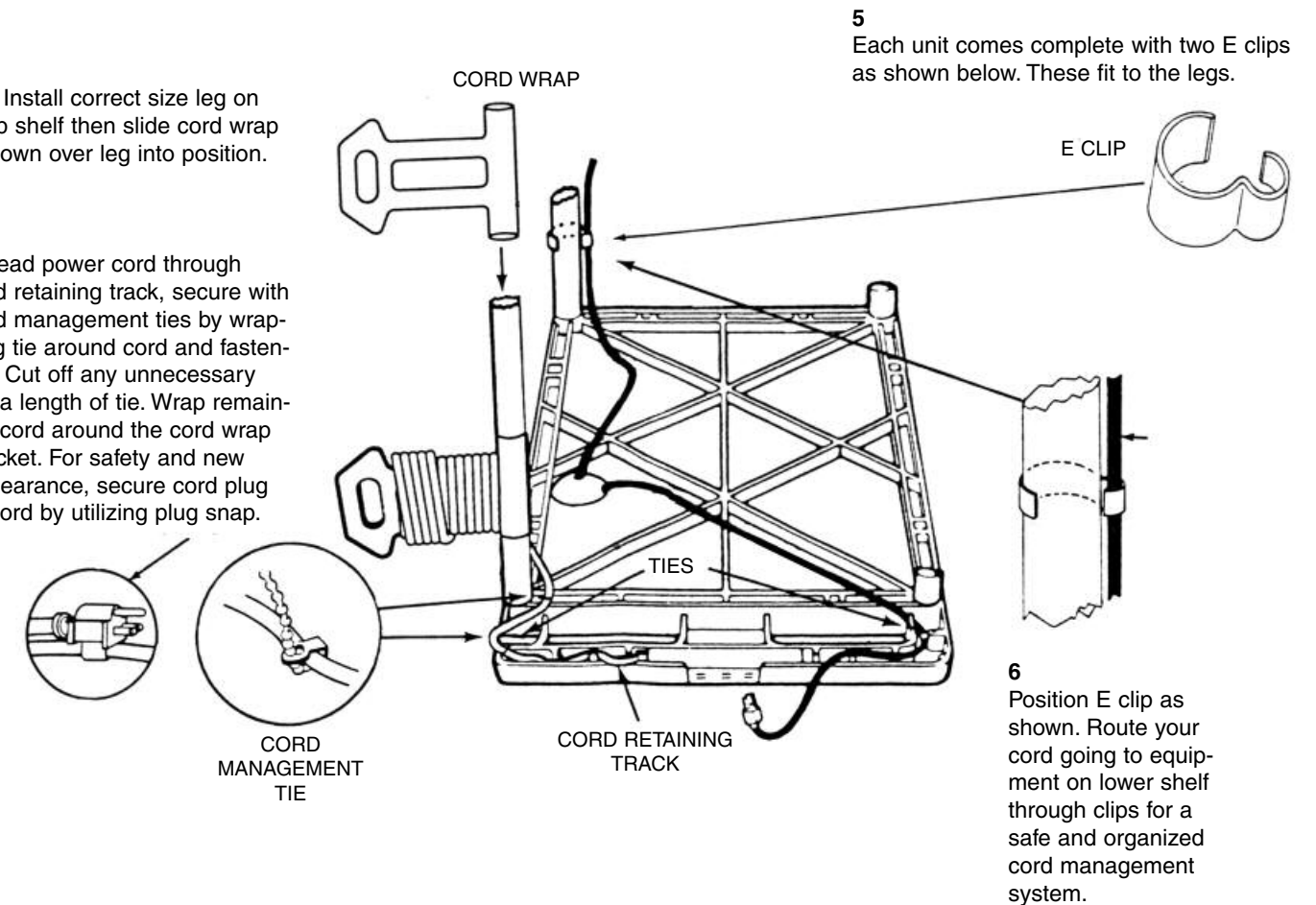

- 5 Each unit comes complete with two E clips as shown below. These fit to the legs.

- 6 Position E clip as shown. Route your cord going to equipment on lower shelf through clips for a safe and organized cord management system.