

Instruction Sheet

Models TL2435, TL2428, TL24P2, TL24P4 & TL28



Customer Service Dept
2245 Delany Rd
Waukegan, IL 60087
Ph: 847/244-1800 • 800/323-4656
Fax: 847/244-1818 • 800/327-1698



TL2435



TL24P4

- Model TL28**
- 1 - 24" x 30" Shelf
 - 3 - #10x1" Phillips Screws
 - 3 - Uprights
 - 1 - Base
 - 2 - Bullet Caps
 - 3 - Logo Caps
 - 3 - 3 1/2" Allen Head Bolts
 - 4 - Casters (2 w/brake)

- Models TL2428 and TL2425**
- 1 - 19" x 24" Shelf
 - 1 - 24" x 30" Shelf
 - 6 - #10x1" Phillips Screws
 - 3 - Uprights
 - 1 - Base
 - 2 - Bullet Caps
 - 3 - Logo Caps
 - 3 - 3 1/2" Allen Head Bolts
 - 4 - Casters (2 w/brake)

- Parts List**
- | | |
|---|---|
| Model TL24P2 | Model TL24P4 |
| 1 - 19" x 24" Shelf | 2 - 19" x 24" Shelf |
| 1 - 19" x 24" Shelf w/paper pass through slot | 2 - 19" x 24" Shelf w/paper pass through slot |
| 6 - #10x1" Phillips Screws | 12- #10x1" Phillips Screws |
| 3 - Uprights | 3 - Uprights |
| 1 - Base | 1 - Base |
| 2 - Bullet Caps | 2 - Bullet Caps |
| 3 - Logo Caps | 3 - Logo Caps |
| 3 - 3 1/2" Allen Head Bolts | 3 - 3 1/2" Allen Head Bolts |
| 4 - Casters (2 w/brake) | 4 - Casters (2 w/brake) |

- Optional Electric Assembly**
- 1 - Surge Protected Power Cord
 - 1 - "U" Bracket
 - 2 - Screws
- Tools Required:**
- Allen Wrench (supplied)
 - Screwdriver
 - Rubber Mallet

SPECIAL NOTE - SEE BELOW

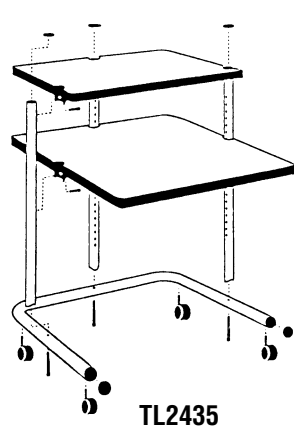

TL2435

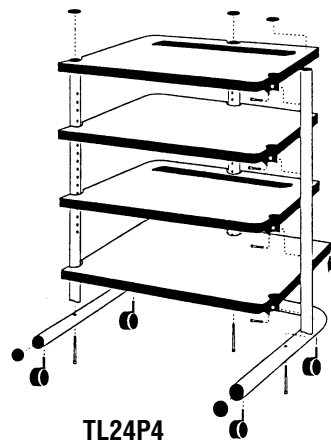

TL24P4

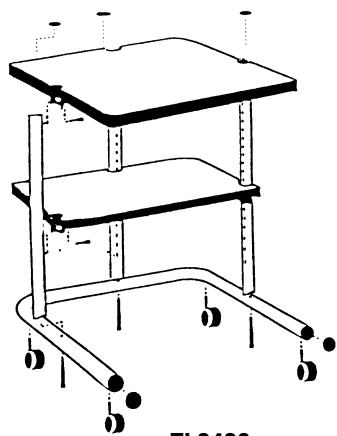

TL2428

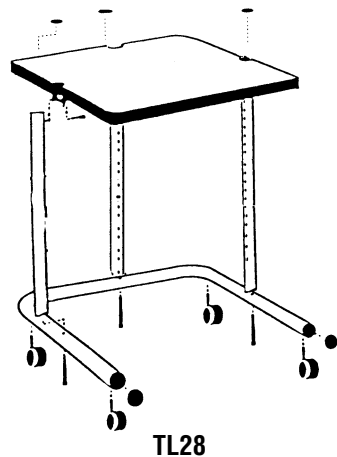

TL28

SPECIAL NOTE: Assembly for these units - TL2435, TL28, TL2428, TL24P2 and TL24P4 are the same. The number of shelves and the type of shelf for your model are the only things to be considered. The TL24P2 is pictured just for reference purposes during assembly of any of the five models.

TL-24-P2

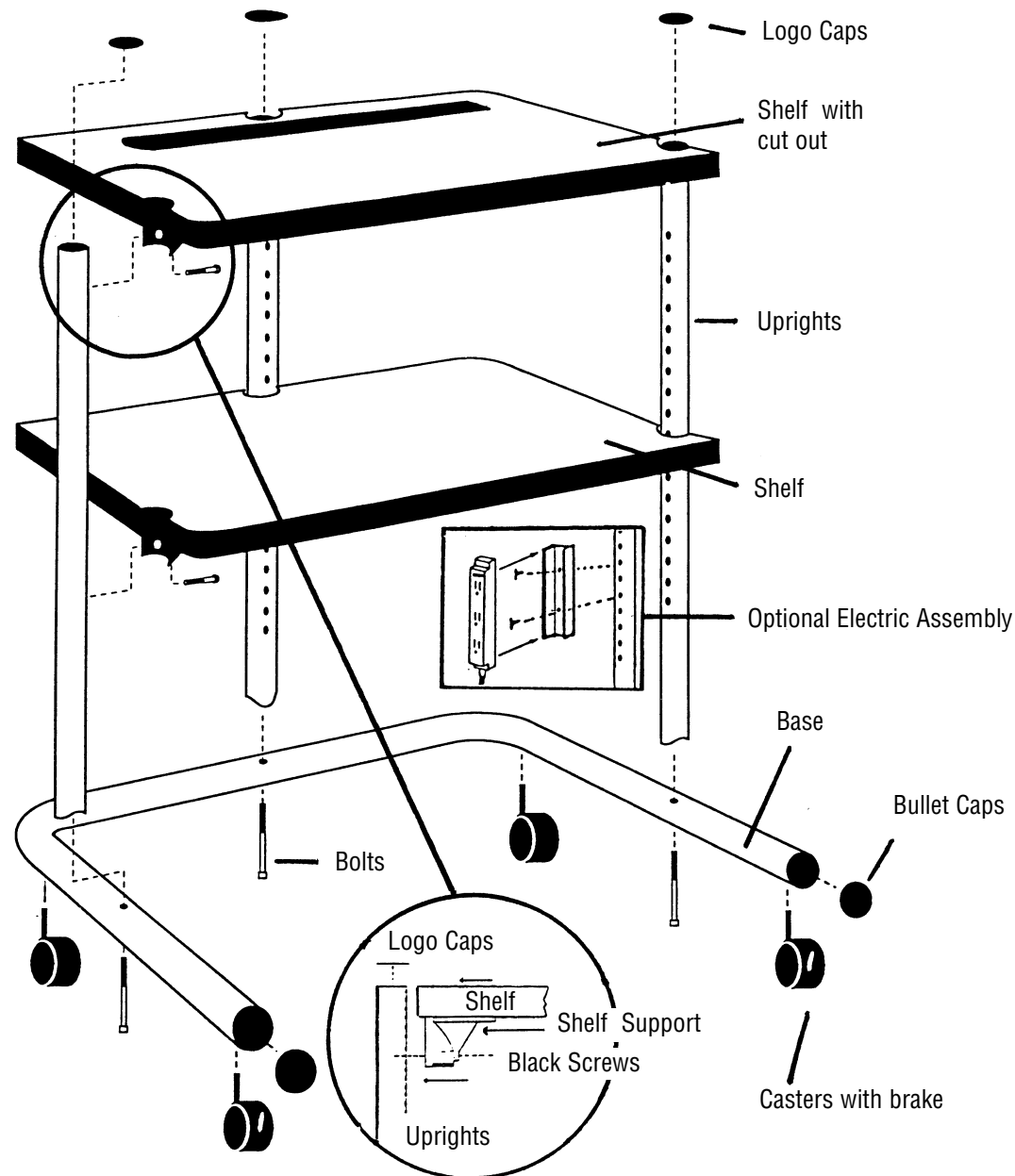

ASSEMBLY

1. Read special note at far left of this instruction sheet.
2. Separate and identify parts for your model.
3. Start by installing bullet caps into ends of base using rubber mallet if necessary. Then identify the top from the bottom on the 3 uprights. The bottom has a cut-away on the one end and the hole locations start at about 2 1/4" from that cut-away. The top of upright is flat. Install logo caps into top of upright.
4. Install casters into caster sockets on base. Casters with brake go in front. All four casters must be fully seated.
5. Attach all three uprights to base at this time. **Note:** Do not fully tighten yet and be sure that the holes on the uprights must face in so shelves can be attached later. The 3 uprights are attached to base using allen head bolts and allen wrench.
6. Lay assembled frame on the single rear upright. Base should be facing up. Attach top shelf for your model (see diagrams at far left for models TL2435, TL2428, TL24P4 or TL28) as shown in diagram using a black screw. **Note:** Only attach shelf to rear uprights at this time. Determine how far apart the remaining shelf or shelves should be and attach to the rear upright in similar fashion. Once you are certain of shelf distances then attach shelves to left and right uprights using black screws making sure you use the same hole locations on all three uprights. If the wrong hole locations are used, the shelves will sit crooked. Fully tighten all shelves to uprights at this time. Now go back and fully tighten the three allen head bolts using the allen wrench. Stand unit right side up. Unit is now ready for use.

OPTIONAL ELECTRIC ASSEMBLY

7. Take U bracket and install where you desire using two black screws. Insert suppressing power cord into U bracket. Assembly is now complete.