

Instruction Sheet

Models TVP-44C and TVP-44LTC



Customer Service Dept
2245 Delany Rd
Waukegan, IL 60087
Ph: 847/244-1800 • 800/323-4656
Fax: 847/244-1818 • 800/327-1698



Parts List

- | | |
|------------------------------|------------------------|
| 1 - TVP-44C or 1 - TVP-44LTC | 4 - Sure Grip Pads |
| 2 - Side Panels | 2 - Casters |
| 1 - Back Panel | 2 - Casters With Brake |
| 1 - Set of Doors | 16 - Caster Bolts |
| 1 - Handle | 16 - Nuts |
| 4 - Screws | 16 - Lock Washers |
| 1 - Power Cord | |

Tools Required:
1/2" Open End Wrench
Slotted Screwdriver

1 Turn your equipment table upside down.

INSTALL SWIVEL CASTERS ON END OF TABLE WITH HANDLE

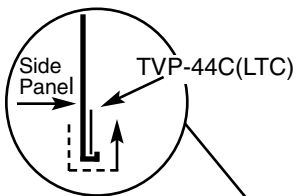

SIDE VIEW OF BACK AND LEFT AND RIGHT SIDES

TOP OF PANEL HAS LIP

BOLT HOLES

BOTTOM OF PANEL HAS BOLT HOLES

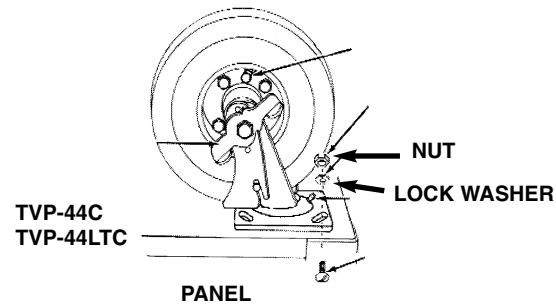
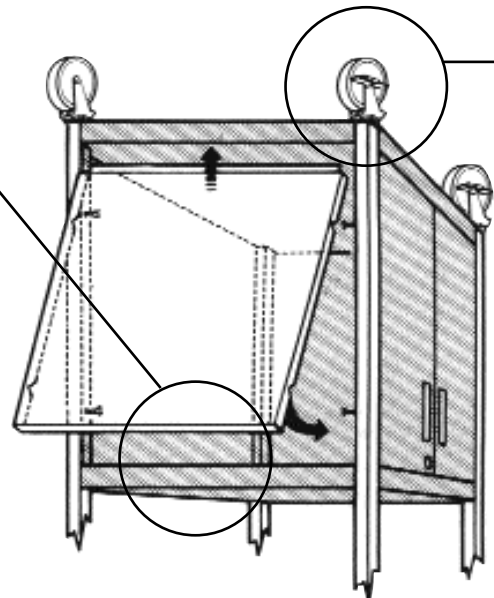

TVP-44C
TVP-44LTC

Bolt goes through hole in cabinet panel first, then through TVP unit then up through caster plate

Replacement parts may be purchased from your Luxor dealer should you encounter a problem with your pneumatic casters.

Part No.	Description
80111	Inner Tube only
80109	8" pneumatic wheel w/o brake
80110	8" pneumatic wheel w/ brake
80000	Tire only

2 SIDE VIEW OF DOOR

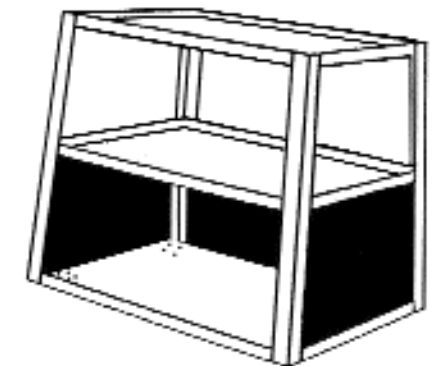
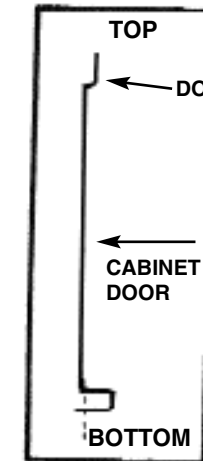

3

1. Affix Sure Grip Pads to the top shelf of monitor table under foot pattern of equipment placed on table to keep equipment from sliding when unit is being moved. To install pads, remove backing and stick to top of surface.

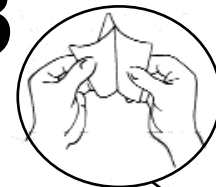

SLOT FOR OPTIONAL SAFETY BELT

SURE GRIP PADS

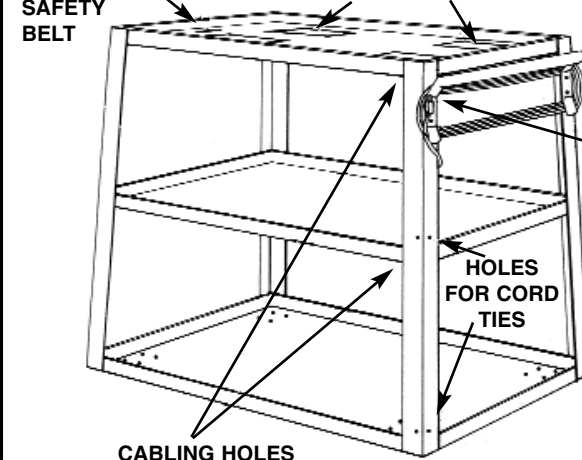

CABLING HOLES

HOLES FOR CORD TIES

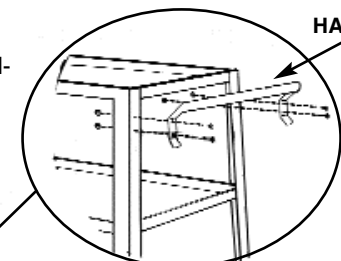

2. Position push handle over mounting holes in end of table and secure with 4 small screws and nuts.

HANDLE

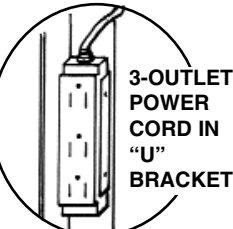

3-OUTLET POWER CORD IN "U" BRACKET

PLUG SNAP

3. Press 3-outlet power cord head into "U" bracket mounted on table leg and wrap remaining cord around handle. For safety and neat appearance, secure cord plug to cord with plug snap

Assembly

- Separate and identify parts. Turn unit upside down. Take back panel and put bottom section in first then hook the top lip of back panel around shelf as illustrated. Take caster bolt, and from inside of cabinet, push through panel, then through TVP Table, then up through plate of caster. Secure with lock washer and nut. NOTE: The side with the handle holes (see step 3) is the side that must get the casters with brake. At this point just put one bolt in the casters. Then when back and sides are in place install door in the same manner.
- Door doesn't have a lip (see door side view step 2). Secure door with bolt, washer and nut. Now all remaining bolts can be installed. Turn unit right side up.
- Install handle using 4 screws. then tap power assembly into "U" bracket and wrap cord around handle. Use plug snap to secure cord. Place sure grip pads on top shelf of TVP44C(LTC) directly under foot pattern of equipment to be put on unit. Unit is now ready for use.