



H. Wilson Company

Phone (800) 245-7224

Fax (800) 245-8224

WPTV28E/ WPTV28CE WPTV42E/ WPTV42CE

Mobile Plasma Mount

Parts List:

- (1) Top shelf with handle & 4 bosses
- (1) Bottom Shelf with caster inserts and four bosses
- (1) Electrical Assembly if 'E' model was purchased
- (2) 4" Swivel casters with brake
- (2) 4" swivel casters

WPTV42C Model Additional Parts:

- (4) Straight Legs/no channels
- (4) Fluted Legs w/channels
- (1) Middle shelf with 8 leg bosses
- (1) Cabinet Pack

WPTV42E Model Additional Parts:

- (8) Straight Legs/no channels
- (1) Middle shelf with 8 leg bosses

WPTV28C Model Additional Parts:

- (4) Fluted Legs w/channels
- (1) Middle shelf with 8 leg bosses
- (1) Cabinet Pack

WPTV28E Model Additional Parts:

- (4) Straight Legs/no channels
- (1) Middle shelf with 8 leg bosses

*****NOTE: Fluted legs should be placed over bosses with the fluted channels towards each other, facing in.**

1. Place top shelf on firm surface, underside up. For WPTV28CE use fluted legs at this time. For WPTV42CE, use straight legs at this time. Insert legs onto leg bosses. Press fit as much as possible with hands. Tap firmly with rubber mallet if necessary.

2. If making a WPTV28CE, your table has no middle shelf, please proceed to step 4. Otherwise, position middle shelf, underside up, onto legs. Press fit as much as possible with hands. Using rubber mallet, firmly seat legs into shelf.

3. FOR WPTV42CE ONLY - Place 16½" fluted legs onto leg bosses. Press fit as much as possible with hands. Seat firmly with rubber mallet.

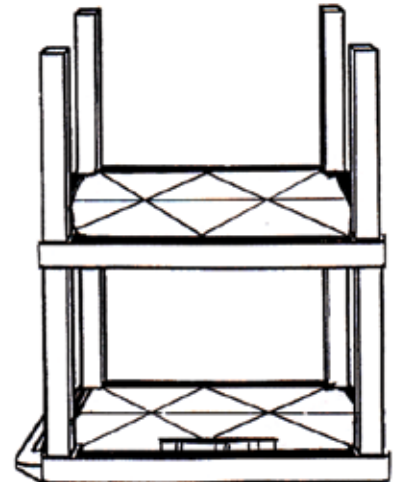
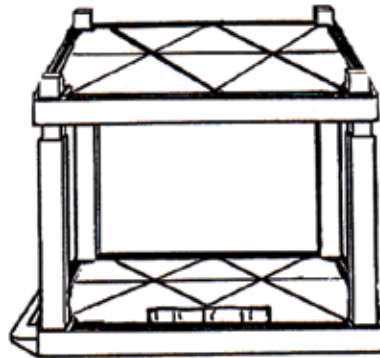
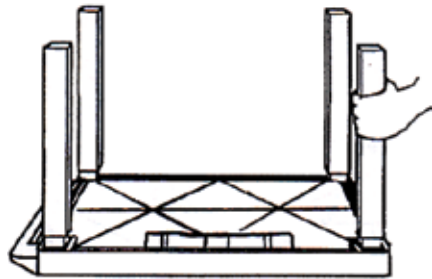

Step 4: Locate back panel and slide down into grooves of the 2 back legs (same side as electrical bracket on top shelf). Take the two side panels, slide into place. Take front panel and slide into place positioned so that the lock will be on the left.

5. Position bottom shelf, underside up, onto legs. Firmly seat shelf onto legs using rubber mallet.

6. Insert casters into caster sockets, making sure that you have the two locking casters in the caster sockets on the 18" long side of the cart that has the handle.

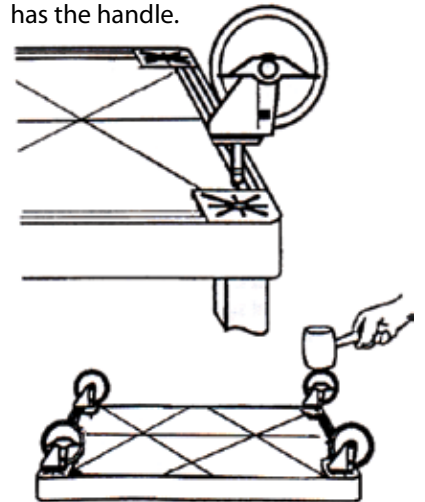
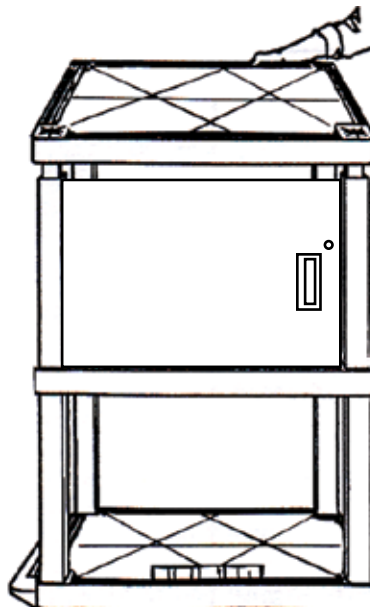
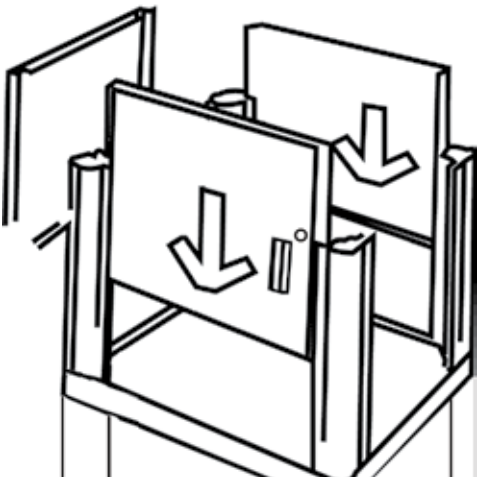

To attach the electrical assembly, please see the instructions included with the assembly.

Parts for WPSMS

- (1) Base
- (2) Poles
- (1) Mounting Bracket for Pedestal
- (4) 3 1/4" Machine Bolts
- (4) Self-locking Nuts
- (4) 5/16 -18" Bolts
- (4) Washers
- (4) Nuts

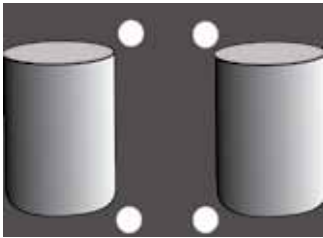

**Mounting Bracket
for Pedestal**



Instructions:

1. Put base on middle shelf secure with bolts. *Please note base has been redesigned with a rectangle base instead of the 'W' shown in photos. This does not change the assembly.
2. Place poles through the holes in the top shelf and seat in the uprights on the base. Secure with bolts.
3. Place mounting bracket for Pedestal over pole ends at desired height. Secure with bolts.
4. Open box for WFST, Single Stud Plasma Mount, and take out the Large plate, Attach to Pedestal Mounting Bracket, by lining up the 4 holes and securing with (4) 5/16-18" bolts, washers and nuts.
5. Put mounting arms onto back of TV and secure with appropriate hardware (included with WFST mount).
6. Follow instructions included with WFST mount.