

ASSEMBLY INSTRUCTIONS FOR LAMINATOR CARTS

WTV28CE

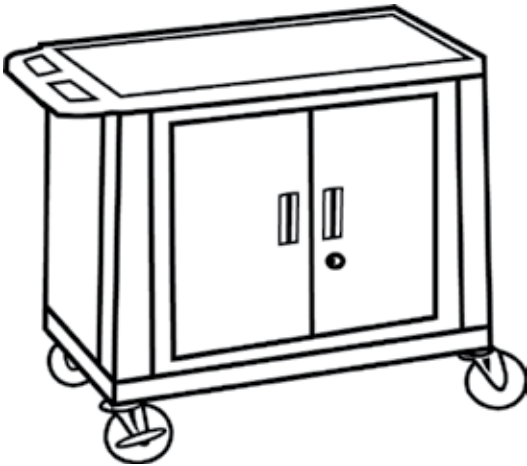

PARTS LIST:

- | | |
|---|----------------------------|
| 1. (1) Top shelf (with handle) | 6. (1) Electrical assembly |
| 2. (1) Bottom shelf (with caster inserts) | 7. (1) Back Panel |
| 3. (4) Fluted Legs | 8. (2) Side Panels |
| 4. (2) 4" Swivel casters (with brake) | 9. (1) Door Panel |
| 5. (2) 4" Swivel casters (without brake) | |

For your convenience: The electrical assembly, if ordered, should be attached to the top shelf before beginning the regular assembly of the table.

Please refer to the instructions included with the electrical assembly.

*Please Note: Rubber mallet not included.

STEP 1: Place bottom shelf upside down (ribbed surface up) on a level and firm floor surface. Insert the stems of the 4 casters into the holes in the four caster posts. Tap casters into socket with rubber mallet* until fully seated. (FIGURE 1)

STEP 2: Place the four fluted legs over the corner posts so that the channels face each other. The legs have notches on both ends. The end with the shorter notch should be placed over the bosses on the lower shelf. Use a rubber mallet* to tap legs into place. make sure that legs are even and fully seated. (FIGURE 2)

STEP 3: Locate back panel and slide down into grooves of the 2 back legs. Take the two side panels, slide into place. Take front panel and slide into place with the lock positioned as shown. (FIGURE 3)

STEP 4: Take top shelf and place onto legs so that the bosses are fitting into the holes in the top of the legs. The top shelf should be placed over the longer notches. Be sure that the ribbed side is facing down. Push shelf down as far as you can by hand. Gently tap with mallet* if necessary. (FIGURE 4)

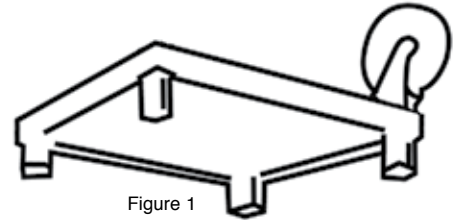

Figure 1

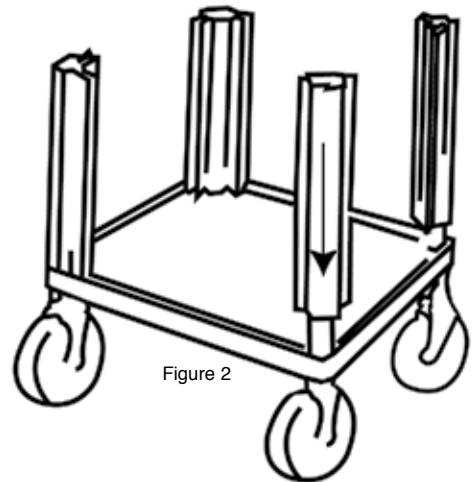

Figure 2

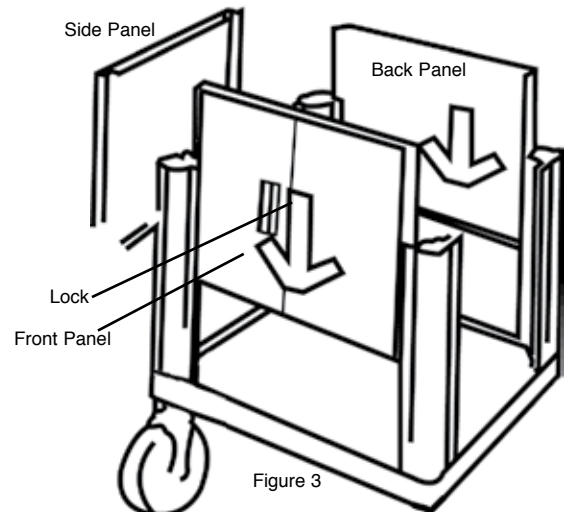

Figure 3

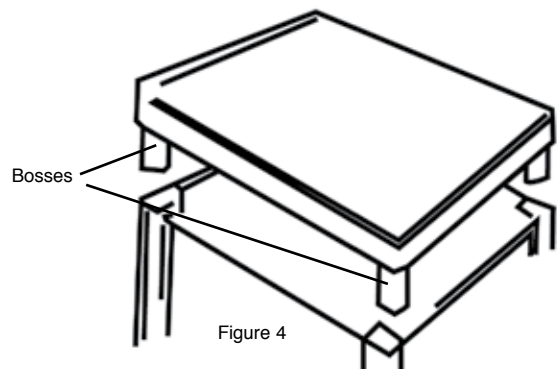

Figure 4



H. Wilson Company
2245 Delany Road
Waukegan, IL 60087
Phone (800) 245-7224
Fax (800) 245-8224