



H. Wilson Company
 555 West Taft Drive
 South Holland, IL 60473
 (800) 245-7224
 sales@hwilson.com

WT16, WT26, WT34, WT42 & WT1642 Tuffy Cart Assembly Instructions

Parts List:

- (1) Top shelf with handle
- (1) Middle shelf with 8 leg bosses
- (1) Bottom Shelf with caster inserts and four bosses
- (1) Electrical Assembly if 'E' model was purchased

- (4) 8 1/2" Legs
- (8) 16 1/2" legs
- (3) Cable Management Clips
- (2) 4" Swivel casters with brake
- (2) 4" swivel casters

Required Tools
 (not included)



Rubber Mallet

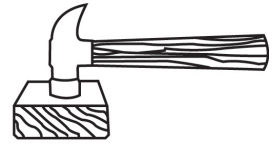

Optional: metal hammer with block of wood to cushion impact.

| TO MAKE A | ASSEMBLED HEIGHT | USE THESE LEGS | USE THESE SHELVES |
|-----------|------------------|------------------------|----------------------|
| WT16 | 16 1/2" | 8 1/2" | TOP & BOTTOM |
| WT26 | 24 1/2" | 16 1/2" | TOP & BOTTOM |
| WT34 | 34" | 1 SET 8 1/2" & 16 1/2" | TOP, MIDDLE & BOTTOM |
| WT42 | 42 1/2" | 2 SETS OF 16 1/2" | TOP, MIDDLE & BOTTOM |

1. Place top shelf on firm surface, underside up. Insert legs onto leg bosses. Press fit as much as possible with hands. Tap firmly with rubber mallet if necessary. For WT16, WT26 & WT34 use 8 1/2" legs at this time. For WT42, use 16 1/2" legs at this time.

2. If making a WT16 or WT26, your table has no middle shelf, please proceed to step 4. Otherwise, position middle shelf, underside up, onto legs. Press fit as much as possible with hands. Using rubber mallet, firmly seat legs into shelf.

3. FOR WT34 & WT42 ONLY - Place 16 1/2" legs onto leg bosses. Press fit as much as possible with hands. Seat firmly with rubber mallet.

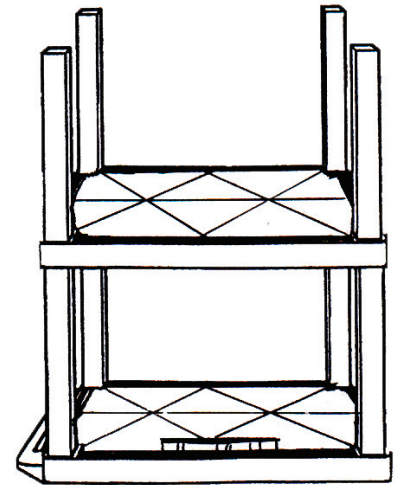
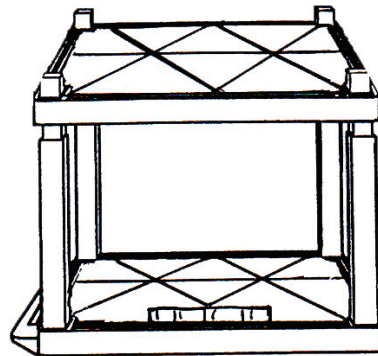
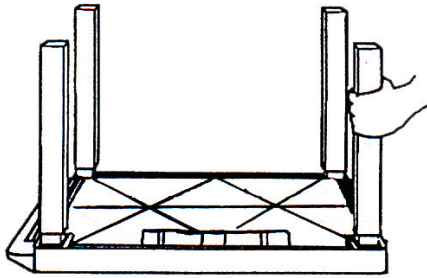

4. Position bottom shelf, underside up, onto legs. Firmly seat shelf onto legs using rubber mallet.

5. Insert casters into caster sockets, making sure that you have the two locking casters in the caster sockets on the 18" long side of the cart that has the handle.

To attach the electrical assembly, please see the instructions included with the assembly.

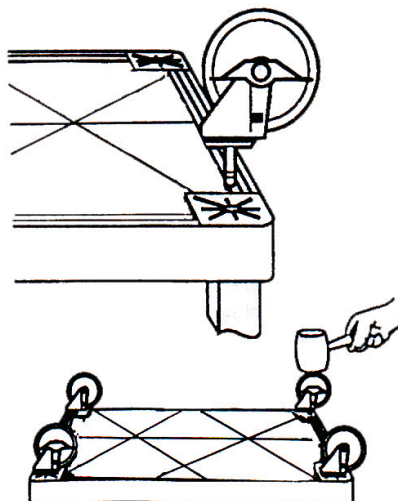
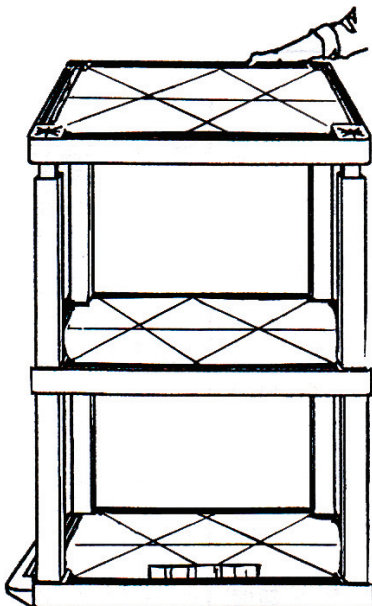

Note: You may have extra legs after assembly is finished, depending on the height you choose to make your cart.