



Virco, Inc.
2027 Harpers Way
Torrance, Ca 90501

Virco, Inc.
Highway 65, South
Conway, AR 72032

Customer Service: (800) 448 - 4726

KAVP2418ADJ Adjustable Height Plastic AV Cart

Parts List:

- (1) Top shelf with handle
- (1) Middle shelf with 8 leg bosses
- (1) Bottom Shelf with caster inserts
- (1) Set of 4 - 8" legs
- (2) Set of 4 - 16" legs
- (3) Cable Management Clips
- (2) 4" Swivel casters with brake
- (2) 4" swivel casters

Required Tools
(not included)

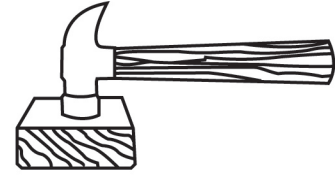

Optional: metal hammer with block of wood to cushion impact.

1. Place top shelf on firm surface, underside up. Insert legs onto leg bosses. Pound firmly with rubber mallet. (To make a 16" or 34" high cart use 8" legs at this time. For 26" or 42" heights, use 16" legs.) If making a 16" or 26" high cart, proceed to step 4 and set middle shelf aside.

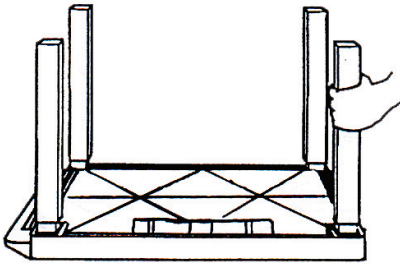

2. If not using middle shelf, proceed to step 4. Otherwise, position middle shelf, underside up, onto legs. Using rubber mallet, firmly seat legs into shelf.

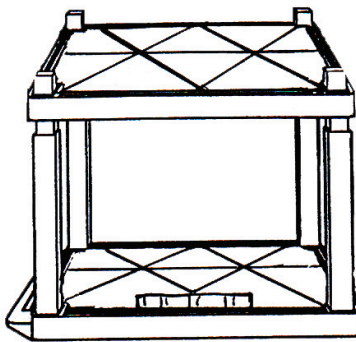

3. Place remaining legs onto leg bosses. Seat firmly with rubber mallet.

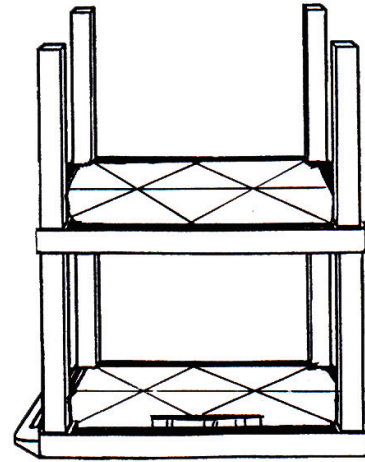

4. Position bottom shelf, underside up, onto legs. Firmly seat shelf onto legs using rubber mallet.

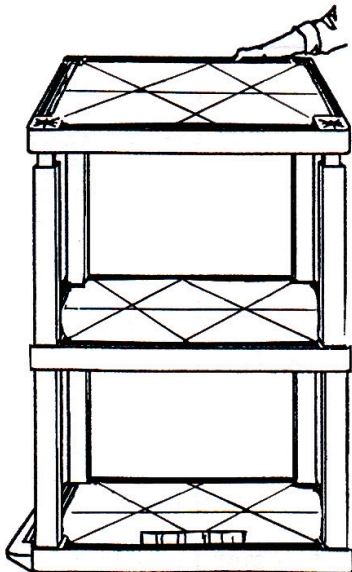

5. Insert casters into caster sockets, making sure that you have the two locking casters in the caster sockets on the 18" long side of the cart that has the handle. Fully seat casters with mallet.

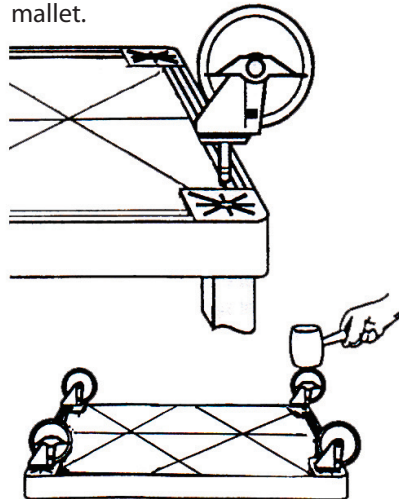

Turn Cart Right Side Up To Attach Electrical Assembly

Install Electrical Assembly

1. Turn cart upright so that molded electrical bracket is facing you.
2. Place Metal Cordwrap onto the molded electrical bracket and align all screw holes.
3. Place the two screws through the inner holes of the electrical.
4. Place the electrical, with the two screws through the specified holes of the cordwrap and mounting bracket.
5. Secure screws with wingnuts.

