



Virco, Inc.
2027 Harpers Way
Torrance, Ca 90501

Virco, Inc.
Highway 65, South
Conway, AR 72032

Customer Service: (800) 448 - 4726

KAVP322754 **Wide-body Plastic AV Cart**

Parts List:

- (1) Top shelf with handle
- (1) Middle shelf with 8 leg bosses
- (1) Bottom Shelf with caster inserts
- (1) Set of 4 - curved legs
- (2) Set of 4 - straight legs
- (3) Cable Management Clips
- (2) 4" Swivel casters with brake
- (2) 4" swivel casters

Required Tools
(not included)



Rubber Mallet

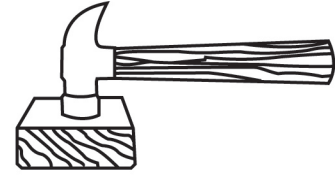

Optional: metal hammer with block of wood to cushion impact.

1. Place top shelf on firm surface, underside up. Insert curved legs onto leg bosses as shown in diagram below. The legs need to curve out towards the shorter edge of the top shelf to accommodate the wider middle shelf. Pound firmly with rubber mallet.

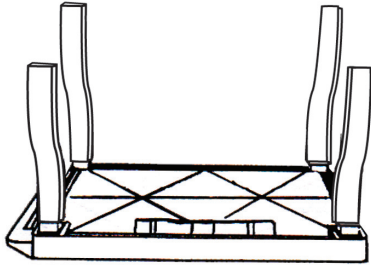

2. Position middle shelf, underside up, onto legs. Using rubber mallet, firmly seat legs into shelf.

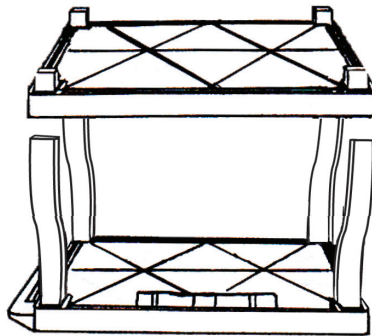

3. Place remaining straight legs onto leg bosses. Seat firmly with rubber mallet.

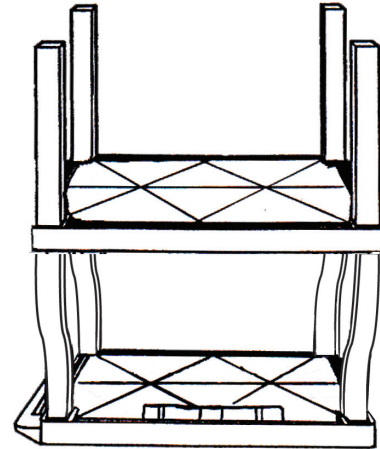

4. Position bottom shelf, underside up, onto legs. Firmly seat shelf onto legs using rubber mallet.

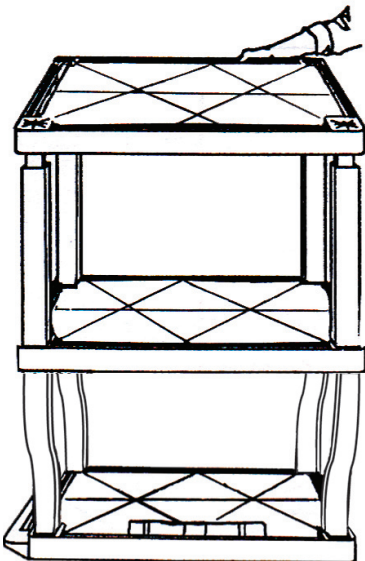

5. Insert casters into caster sockets, making sure that you have the two locking casters in the caster sockets on the 24" / 27" long side of the cart that has the handle. Fully seat casters with mallet.

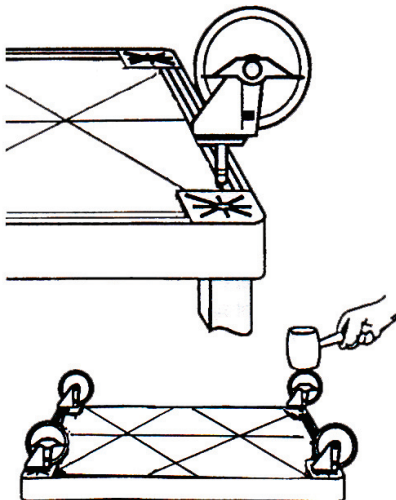

Turn Cart Right Side Up To Attach Electrical Assembly

Install Electrical Assembly

- 1. Turn cart upright so that molded electrical bracket is facing you.
- 2. Place Metal Cordwrap onto the molded electrical bracket and align all screw holes.
- 3. Place the two screws through the inner holes of the electrical.
- 4. Place the electrical, with the two screws through the specified holes of the cordwrap and mounting bracket.
- 5. Secure screws with wingnuts.

