



Virco, Inc.
2027 Harpers Way
Torrance, Ca 90501
Customer Service: (800) 448 - 4726

Virco, Inc.
Highway 65, South
Conway, AR 72032

KAVUL322848 **Widebase Video Cart**

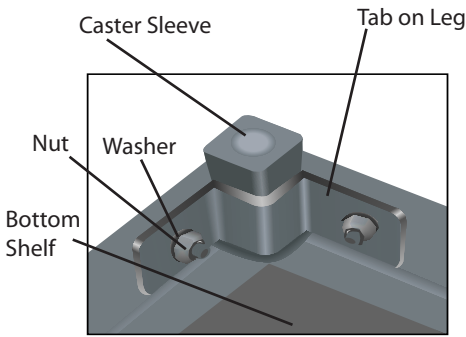

Figure 2

PARTS LIST

1. (4) casters
2. (4) legs (2 SETS OF 2 MATCHING)
3. (24 each) screws, locknuts and washers.
4. (1) Top shelf with logo & grommet hole.
5. (1) Electrical Assembly
6. (1) Middle shelf (no logo, larger than top shelf, no grommet hole)
7. (1) Bottom shelf (no logo, larger than top shelf, no grommet hole) Has 2 small oval holes in the front of the shelf.

You will need the following tools: 10mm Wrench Rubber Mallet Phillips screwdriver

READ INSTRUCTIONS BEFORE BEGINNING - TWO PEOPLE NEED TO ASSEMBLE THE CART

1. There are four legs, two sets of two matching (due to the holes in the legs for cabinet door attachment. Make sure that the *holes in the legs are facing towards each other*.

KEEP CART ON SIDE WHEN POSITIONING SHELVES - JUST TIGHTEN BOLTS BY HAND UNTIL ALL THREE SHELVES ARE CORRECTLY POSITIONED

2. Place two matching legs on the ground. There must be one tab flat to the floor and one upwards, **TABS ON THE FLOOR ARE POINTED TOWARDS EACH OTHER.**

3. Fit the bottom shelf (WIDER side of shelf) over the tabs next to the caster sleeves (see figure 2) making sure that the tabs are fitted underneath the shelf (see figure 1 & 2).

6. Take screws and fit through the holes on shelves and leg tab with the head of the bolt on the outside of the shelf. (There is a **SQUARE** base built on the screw to fit with the **SQUARE** hole on the shelf. **THE SCREWS MUST FIT INTO THIS**

SQUARE PROPERLY OR YOUR CART WILL NOT BE ASSEMBLED CORRECTLY SEE FIGURE 3) Put washers over the ends of the screws and tighten with locknuts. (Just tighten by hand at first or it will be difficult to fit middle and top shelves).

4. Repeat steps 2, 3 and 4 with the middle and top shelves (WIDER side of shelves over tabs) ensuring that the small holes in the front of the bottom shelf are opposite to the grommet hole in the top shelf.

5. Take the other two matching legs and fit onto the three shelves with the tabs underneath the shelves.

7. Using the wrench or socket wrench, tighten all locknuts until very secure, making sure that the square on the bolt is seated in the hole on the leg.

8. Turn cart upside down. Using the rubber mallet, insert casters into caster sleeve. Tap until firmly in place.

9. Turn cart right side up. Please check to make sure that all screws and locknuts are tightened properly.

10. Follow enclosed electrical assembly attachment instructions

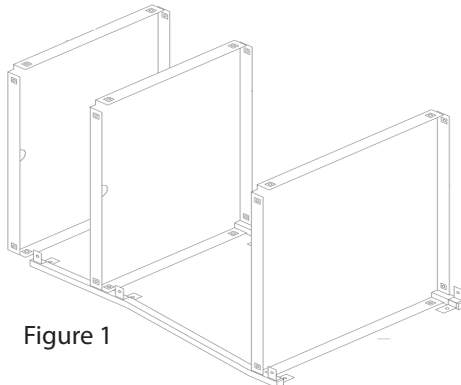

Figure 1

Figure 3

