



Virco, Inc.  
2027 Harpers Way  
Torrance, Ca 90501

Virco, Inc.  
Highway 65, South  
Conway, AR 72032

**Customer Service: (800) 448 - 4726**

# **KCABP322744** **Wide-body** **Plastic AV Cart** **With Cabinet**

**Parts List:**

- (1) Top shelf with handle
- (1) Middle shelf with 8 leg bosses
- (1) Bottom Shelf with caster inserts
- (1) Set of 4 - curved legs
- (1) Set of 4 - 16" fluted legs
- (3) Cable Management Clips
- (2) 4" Swivel casters with brake

- (2) 4" swivel casters
- (1) Cabinet Pack with a front, back & 2 side panels

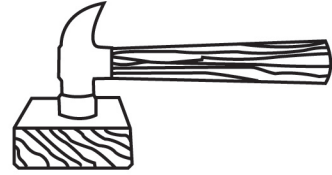
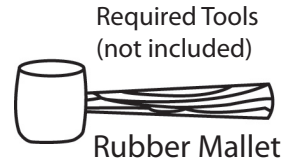

Optional: metal hammer with block of wood to cushion impact.

1. Place top shelf on firm surface, underside up. Insert curved legs onto leg bosses as shown in diagram below. The legs need to curve out towards the shorter edge of the top shelf to accommodate the wider middle shelf. Pound firmly with rubber mallet.

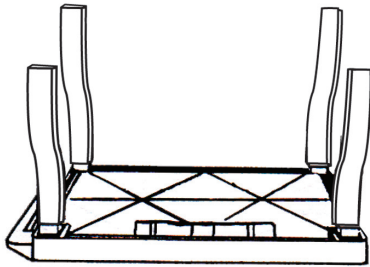

2. If not using middle shelf, proceed to step 4. Otherwise, position middle shelf, underside up, onto legs. Using rubber mallet, firmly seat legs into shelf.

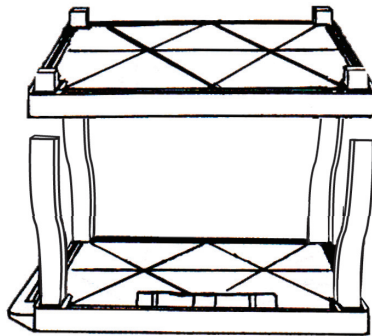

3. Place fluted legs onto leg bosses making sure that the flutes (channels) line up with the shelf edges, facing inwards. Seat firmly with rubber mallet.

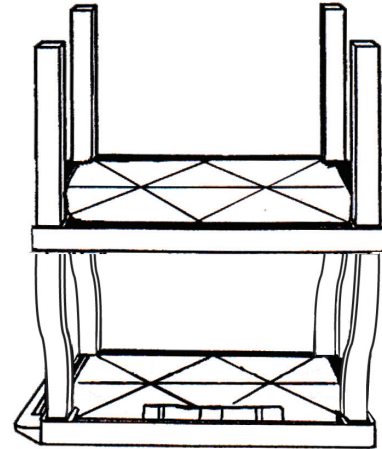

4. Slide cabinet panels into flutes on legs as shown below. Make sure that the back panel with the grommet hole is opposite the front panel. The two side panels are to be positioned on the shorter side of the shelf.

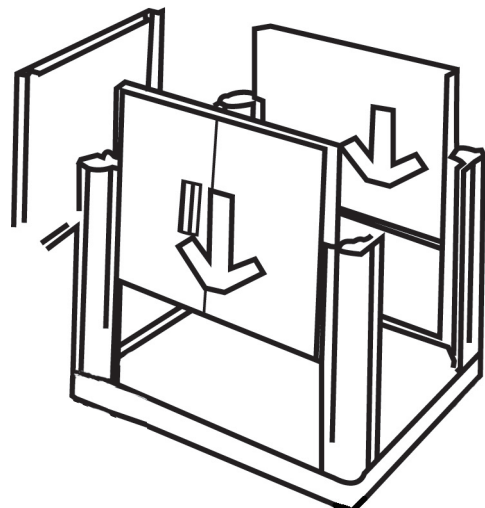

5. Place bottom shelf bosses into the holes in the fluted legs. Fully seat with mallet. Insert casters into caster sockets, making sure that you have the two locking casters in the caster sockets on the 18" long side of the cart that has the handle. Fully seat casters with mallet.

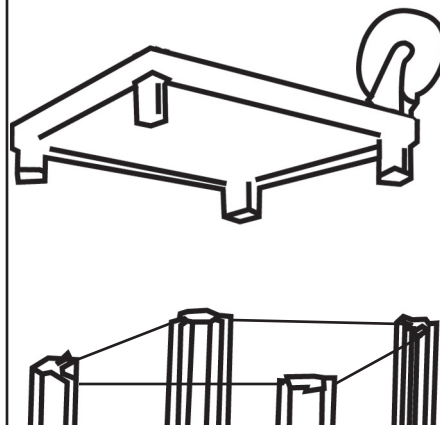

Turn Cart Right Side Up To Attach Electrical Assembly

Install Electrical Assembly

- 1.) Turn cart upright so that molded electrical bracket is facing you.
- 2.) Place Metal Cordwrap onto the molded electrical bracket and align all screw holes.
- 3.) Place the two screws through the inner holes of the electrical.
- 4.) Place the electrical, with the two screws through the specified holes of the cordwrap and mounting bracket.
- 5.) Secure screws with wingnuts.

