



H. Wilson Company

555 West Taft Drive
South Holland, IL 60473
Phone: (800) 245-7224
Fax: (800) 245-8224
Email: sales@hwilson.com
Visit: www.hwilson.com

REVISED 6/08

WPS4E & WPS4BRE

NOTE: The 'BR' in the model number is a color designation. WPS4E is the same unit as WPS4BRE. WPS4CE is the same as WPS4BRCE. Model numbers in the instructions do not have the color designation

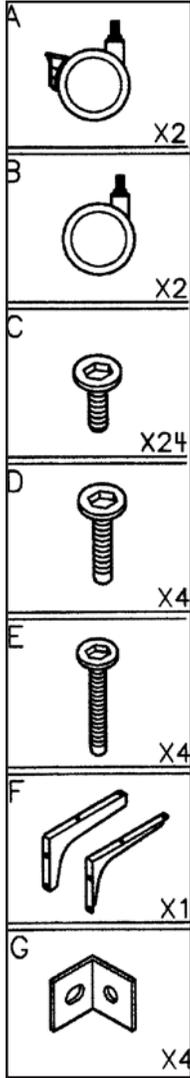

Parts List

- (1) Top Shelf (18"W x 16"L)
 - (1) Adjustable Shelf (18"W x 18"L)
 - (1) Middle Shelf (15"W x 15"L)
 - (1) Bottom Shelf (15"W x 30 1/2"L)
 - (1) Modesty Panel (18"L x 16 1/2"W)
 - (1) Left Side Frame
 - (1) Right Side Frame
 - (4) Plastic Plugs
 - (4) Stickers
 - (1) Wrench
 - (4) Flat Washers
 - (4) Spring Washers
 - A. (2) Locking 3" Casters
 - B. (2) Non-locking 3" Casters
 - C. (24) 3/4" Panhead Screws
 - D. (4) 2" Flathead Screws
 - E. (4) 2" Panhead Screws
 - F. (2) Support Brackets for Second Shelf
 - G. (4) Small Brackets for Top Shelf
 - H. (4) Locking Nuts
- Allen Wrench Included



Important Assembly Tip:
When assembling a WPS4E OR a WPS4CE, do not tighten the screws all the way down. Leave them approximately 1/2 turn out. When unit is fully assembled, tighten screws all the way. This will allow the unit to line up correctly.

If you have purchased a unit with a cabinet please refer to WPS4CE, Cabinet Instructions on Page 2.

Instructions for Open Shelf (No Cabinet):

1. Take one of the side frames and lay flat. Attach bottom shelf to side frame using (2) 2" flathead screws & locknuts. Take frame assembly and position it so that the side panel is resting on the back edge and the shelf is in a vertical position. Attach the second side frame panel to the bottom shelf. (Figure 1)
2. To attach the casters, insert first the spring washer, then the flat washer over the stem in the caster. Screw in threaded caster. Do the same for all (4) casters, making sure that the locking casters are on the same side. Tighten casters with wrench that is provided. (See Image #1)
3. Take Modesty Panel (18" x 16 1/2") and attach using (8) 3/4" screws (C). (See Image #4). Attach to side of panels where the bottom shelf extends further out.
4. Attach middle shelf (15" x 15") (one flat side/one rounded side) using (4) 2" screws (E). Put screws through the guide holes that are on the side panels making sure that flat side of shelf is flush with the side where the bottom shelf extends further out. (See Image #2)
5. Take top shelf (18" x 16") and attach the (4) small "L" shaped brackets (G) to the underside of the shelf. (See Image #3) The brackets have two different style holes on them (perfectly round and oval). Attach the round side to the bottom of the shelf using (4) 3/4" (C) screws, making sure that the other side of the bracket is facing towards the outside of the shelf. When attaching shelf to top of side panels make sure the "L" brackets line up with the pre-drilled holes on the side panels. Attach using (4) 3/4" screws (C).

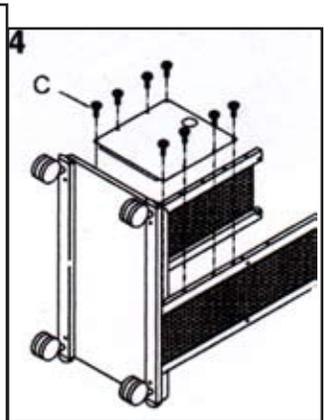
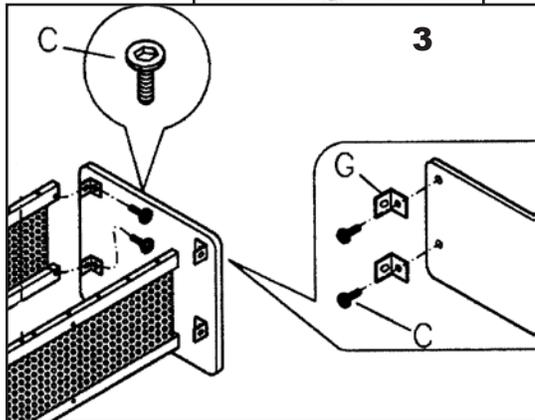
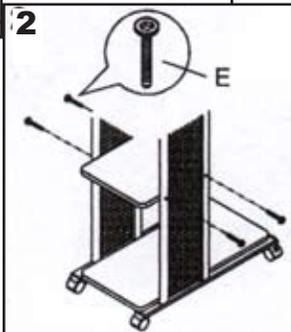
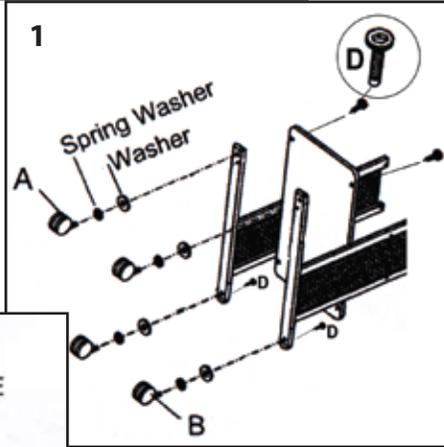

6. Take adjustable shelf (18" x 18") and attach the (2) large "L" support brackets (F) using (4) 3/4" screws (C) making sure that the smooth side of the bracket is facing the outside of the shelf. Then take adjustable shelf and attach to the panels at the desired height using (4) 3/4" screws. (If you would like the adjustable shelf lower, you may take out the top (2) screws of the Modesty Panel and line up the bottom hole of the brackets with the top hole of the Modesty Panel and attach using the 3/4" screws). (Image #5)

7. Insert the (4) grommets into the holes on the bottom shelf. Place sticker over the smaller hole. (Image #6)

Electrical Option: If you received the unit with an electrical assembly you may attach the electrical assembly vertically on the outside or inside of the side panels. Attaching with the screws and wing nuts provided with the electrical packet.

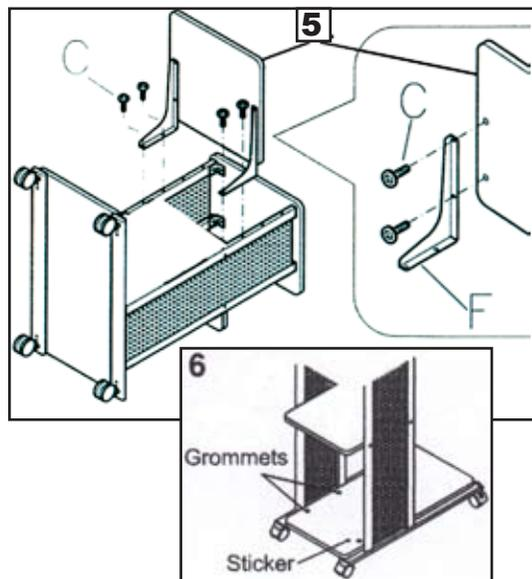

WPS4CE & WPS4BRCE Presentation Station with Cabinet



Instructions:

1. Take one of the side frames and lay flat. Attach bottom shelf to side frame using (2) 2" flathead screws & locknuts. Take frame assembly and position it so that the side panel is resting on the back edge and the shelf is in a vertical position. Attach the second side frame panel to the bottom shelf. (Figure 1)
2. To attach the casters, insert first the spring washer, then the flat washer over the stem in the caster. Screw in threaded caster. Do the same for all (4) casters, making sure that the locking casters are on the same side. Tighten casters with wrench that is provided. (See Image #1)
3. Take Middle Shelf (Cabinet Top Shelf 15" x 15") and using (2) chipboard screws (J) insert the magnetic catch (I) into the pre-drilled holes in the shelf. (See Image #2 on next page)

Parts List

- (1) Top Shelf (18"W x 16"L)
- (1) Adjustable Shelf (18"W x 18"L)
- (1) Middle Shelf (15"W x 15"L)
(Cabinet Top)
- (1) Bottom Shelf (15"W x 30 1/2"L)
- (1) Cabinet Left Side Panel
(18 1/4"L x 13 3/4"W)
- (1) Cabinet Right Side Panel
(18 1/4"L x 13 3/4"W)
- (1) Door Panel (25"L x 13 1/4"W)
- (1) Left Side Frame
- (1) Right Side Frame
- (1) Modesty Panel
- (4) Spring Washers
- (4) Flat Washers
- (1) Wrench

- A. (2) Locking 3" Casters
- B. (2) Non-locking 3" Casters
- C. (24) 3/4" Panhead Screws
- D. (4) 2" Flathead Screws
- E. (4) 2" Panhead Screws
- F. (2) Support Brackets for Second Shelf
- G. (4) Small Brackets for Top Shelf
- H. (2) Spindles
- I. (1) Magnetic Catch and Strip
- J. (6) Chipboard Screws
- K. (1) Cam Lock
- L. (2) 5/32" Screws for Handle
- M. (1) Handle

| | |
|---|---|
| A  X2 | H  X2 |
| B  X2 | I  X1 |
| C  X24 | J  X6 |
| D  X4 | K  X1 |
| E  X4 | L  X2 |
| F  X1 | M  X1 |
| G  X4 | |

Instructions (cont.)

4. Take Modesty Panel (18" x 16 1/2") and attach using (8) 3/4" screws (C). (See Image #3). Attach to side of panels where the bottom shelf extends further out.

5. Take the Door Panel (25"L x 13 1/4"W) and using (2) chipboard screws (J) mount the metal magnetic strip (I) to the door and screw into the predrilled holes. Next take the door handle (M) and (2) 5/32" screws (L) and screw the handle to the door. Take the cam lock (K) and insert it into the predrilled hole on the upper corner of the door. Using (2) chipboard screws (J) attach the cam lock into place. (See Image #4).

6. Take the door and insert two spindles (H), one on top of door and one on the bottom of door. Now take the left cabinet side panel and the right cabinet side panel, line the wood dowels up with the holes in the shelves. Next take the door panel and line the bottom spindle up with the hole in the bottom shelf. Take the cabinet top shelf and place on top of the two side panels and the door making sure to line up the spindle on the door with the hole on the underside of the top shelf. (See Image #5)

7. Once everything is lined up take the (4) 2" screws (E) and secure the top shelf through the holes in the metal side panels, two screws on each side. (See Image #6)

8. Take top shelf (18" x 16") and attach the (4) small "L" shaped brackets (G) to the underside of the shelf. (See Image #7) The brackets have two different style holes on them (perfectly round and oval). Attach the round side to the bottom of the shelf using (4) 3/4" screws, (C) making sure that the other side of the bracket is facing towards the outside of the shelf. When attaching shelf to top of side panels make sure the "L" brackets line up with the pre-drilled holes on the side panels. Attach using (4) 3/4" screws (C).

9. Take adjustable shelf (18" x 18") and attach the (2) large "L" support brackets using (4) 3/4" (C) screws making sure that the smooth side of the bracket is facing the outside of the shelf. Then take adjustable shelf and attach to the panels at the desired height using (4) 3/4" (C) screws. (See Image #8)

Electrical Option: If you received the unit with an electrical assembly you may attach the electrical assembly vertically on the outside or inside of the side panels. Attaching with the screws and wing nuts provided with the electrical packet.

