



H. Wilson Company  
 555 West Taft Drive  
 South Holland, IL 60473  
 Phone: (800) 245-7224  
 Fax: (800) 245-8224

# WE/WEW CARTS

You will need the following tools: 10mm Wrench Rubber Mallet Phillips screwdriver

## PARTS COMMON TO ALL CARTS:

1. (4) casters
2. (4) legs (2 SETS OF 2 MATCHING)
3. (24 each) screws, locknuts and washers.
4. (1) Top shelf with logo & grommet hole.
5. (1) Electrical Assembly

## ADDITIONAL FOR WE CARTS

6. (1) Middle shelf (no logo, no grommet hole)
7. (1) Bottom shelf (no logo, shelf, no grommet hole with 2 small holes in the front for attaching door stop plate if ordering cabinet model)

## ADDITIONAL FOR WEW CARTS

6. (1) Middle shelf (no logo, larger than top shelf, no grommet hole)
7. (1) Bottom shelf (no logo, larger than top shelf, no grommet hole with 2 small holes in the front for attaching door stop plate if ordering cabinet model)

## ADDITIONAL FOR CABINET MODEL CARTS

8. (2) Cabinet Doors (left & right hinge and screws for attachment)
9. (1) Left Cabinet Panel (top of panel is formed to fit under middle shelf.)
10. (1) Right Cabinet Panel (top of panel is formed to fit under middle shelf.)
11. (1) Rear Cabinet Panel (top of panel is formed to fit under middle shelf and has a cable management hole.)
12. (1ea) Upper & Lower Door Stop Plate & packaged screws for attachment.

Assembly Hints:

### **READ INSTRUCTIONS BEFORE BEGINNING**

### **TWO PEOPLE NEED TO ASSEMBLE THE CART**

1. There are four legs, two sets of two matching (due to the holes in the legs for cabinet door attachment. These holes are there even if you do not have a cabinet cart as legs are standardized. Make sure that the *holes in the legs are facing towards each other* where the cabinet doors will be attached

### **KEEP CART ON SIDE WHEN POSITIONING SHELVES - DO NOT ATTACH LEGS TO MIDDLE & BOTTOM SHELVES ON CABINET MODEL UNTIL ATTACHING CABINET!!!**

2. Place two matching legs on the ground as shown in figure 1. There must be one tab flat to the floor and one upwards, TABS ON THE FLOOR ARE POINTED TOWARDS EACH OTHER (see figure 1 & 2).
3. Fit the bottom shelf (WIDER side of shelf) over the tabs next to the caster sleeves (see figure 3) making sure that the tabs are fitted underneath the shelf (see figure 1 & 3).
4. Repeat steps 2 and 3 with the middle and top shelf (WIDER side) ensuring that the small holes in the front of the bottom shelf are opposite to the grommet hole in the top shelf.
5. Take the other two matching legs and fit onto the three shelves with the tabs underneath the shelves.

### **IF YOU HAVE A CABINET MODEL STOP HERE AND PROCEED TO STEP 10 ON NEXT PAGE.**

6. Take screws and fit through the holes on shelves and leg tab with the head of the bolt on the outside of the shelf. (There is a square base built on the screw to fit with the hole on the shelf.) Put washers over the ends of the screws and tighten with locknuts. (Just tighten by hand at first). \*\*\*IF YOU DO NOT HAVE A CABINET MODEL, YOU MAY DO THIS STEP AS THE SHELVES ARE BEING PUT ON THE LEGS.
7. Using the wrench or socket wrench, tighten all locknuts until very secure.
8. Turn cart upside down. Using the rubber mallet, insert casters into caster sleeve. Tap until firmly in place.
9. Turn cart right side up. Please check to make sure that all screws and locknuts are tightened properly.

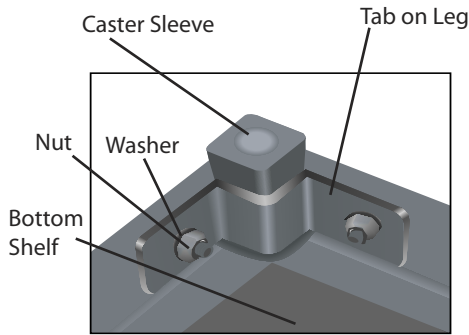

Figure 3

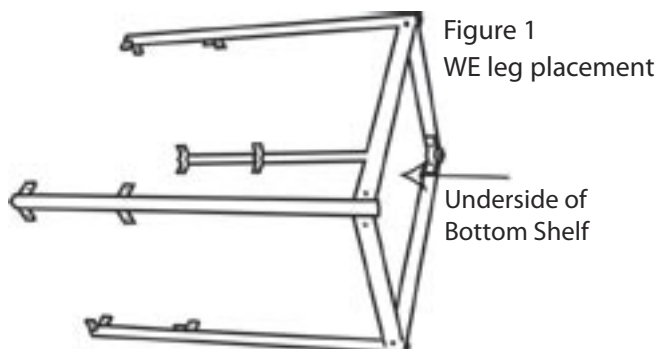

Figure 1  
WE leg placement

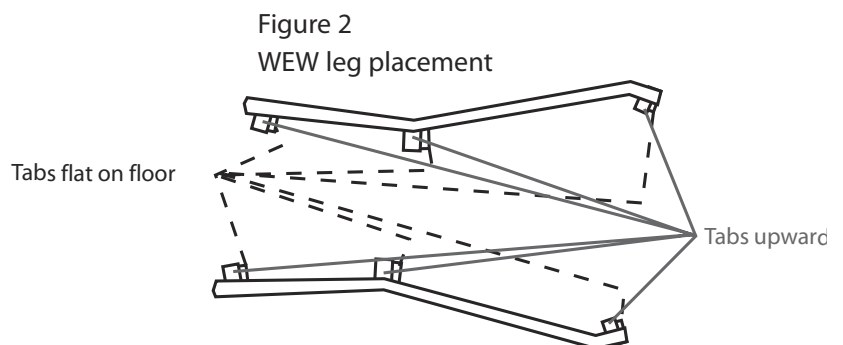

Figure 2  
WEW leg placement

### CABINET MODEL INSTRUCTIONS:

10. Take screws and fit through the holes on TOP SHELF ONLY and leg tab with the head of the bolt on the outside of the shelf. (There is a square base built on the screw to fit with the hole on the shelf.) Put washers over the ends of the screws underneath the shelf and tighten with locknuts. (Just tighten by hand at first).
11. Line up the predrilled holes on the Door Stop Plate to the holes on the front of the bottom shelf & attach with the included black screws so that the part that stops the cabinet door is inset from the edge of the shelf, flush with the raised part of the shelf. Figure 4

Figure 4



12. The right & left & rear panels are shaped so that the top of the panel will fit UNDER THE MIDDLE SHELF and the bottom of the panel will fit OVER THE OUTSIDE of the bottom shelf (see photo below and side view outline to the right) Rear panel has cable management hole closer to the upper edge of the panel, use this as a guide to find the top edge.



One at a time, (rear panel first) put top edge of panel under MIDDLE SHELF bottom of panel over the outside of the BOTTOM SHELF. Attach with screws, washers and locknuts as described in step 9 except the screw will be going through the holes on the cabinet panel & the hole on the shelf. Repeat with other two panels. Attach upper door stop in between the middle shelf and the leg tabs with screws, nuts & bolts.

***\*BEFORE attaching Cabinet doors, put the Upper Door Stop Plate between the front of middle shelf and the leg tabs and attach with screws.***



Cabinet Doors open outward (left & right hinge). Line the hinges up with the predrilled holes in the front legs and attach with the silver enclosed screws. See photo left.

13. Using the wrench or socket wrench, tighten all locknuts until very secure.
14. Turn cart upside down. Using the rubber mallet, insert casters into caster sleeve. Tap until firmly in place.
15. Turn cart right side up. Please check to make sure that all screws and locknuts are tightened properly. Attach Electrical assembly according to enclosed instructions

WEW cabinet cart being assembled on its side - shows leg positioning and cabinet panel placement

