



H. Wilson Company
 555 West Taft Drive
 South Holland, IL 60473
 Phone: (800) 245-7224
 Fax: (800) 245-8224

WEW54IME

You will need the following tools:
 10mm wrench
 Rubber Mallet
 Phillips screwdriver

Parts List for WEW54IME

1. (4) casters
2. (4) legs
3. (1) Top shelf with logo & grommet hole
4. (1) Middle shelf (no logo) grommet hole
5. (1) Bottom shelf (no logo, larger than top and middle shelves, no grommet hole)
6. (1) Keyboard tray/mousepad extender.
7. (1) Cord management bin.
8. (24 each) screws, locknuts and washers.
8. (8) small screws for keyboard/ bin

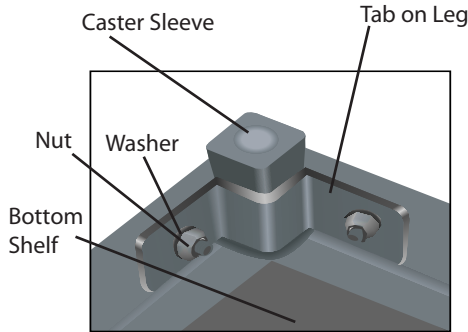
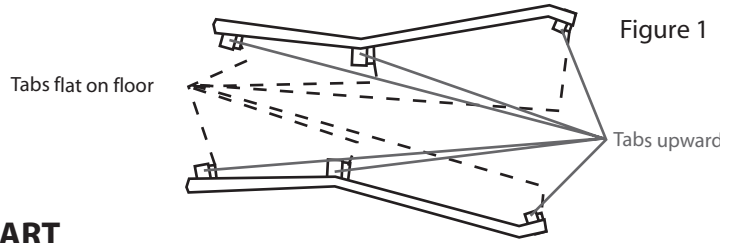

Figure 2



Assembly Hints:

1. Read instructions before beginning.
2. **TWO PEOPLE SHOULD ASSEMBLE THIS CART**
3. There are four legs, (two sets of two matching) due to the bend that makes the cart a widebase unit. Lay legs on the floor as shown in Figure 1 to determine which legs are the same. (Shelves will fit over the flanges, so position the legs so that the tabs are towards each other.)

*Cart should be assembled on its side when attaching shelves.

1. Attach keyboard tray/mousepad extender to the cord management tray using 4 small screws. (Line up to the holes on the front legs and the assembly). Line holes on upper cord management bin to the holes on the short sides of the middle shelf. Attach bin assembly to middle shelf using 4 small screws. (Refer to the finished cart drawing, Figure 4).
2. Place two matching legs on the ground as shown in figure 1. There must be one tab flat to the floor and one upwards. Fit the bottom (largest) shelf (27" side) over the tabs next to the caster sleeves (see figure 3) making sure that the tabs are fitted underneath the shelf (see figure 2).
3. Take two screws and fit through the holes. (There is a square base built on the screw to fit with the hole on the flange.) Put two washers over the ends of the two screws and tighten with locknuts. (Just tighten by hand at first).
4. Repeat step 2 and 3 with the middle and top shelf (22" side) ensuring that the grommet holes are all in the same position. (See Figure 3 & 4.) (Line up to the holes on the front legs and the assembly).
5. Take the other two matching legs and fit onto the three shelves with the tabs underneath the shelves.
6. Using the wrench or socket wrench, tighten all locknuts until very secure.
7. Turn cart upside down. Using the rubber mallet, insert casters into caster sleeve. Tap until firmly in place.
8. Turn cart right side up.
9. Please check to make sure that all screws and locknuts are tightened properly.

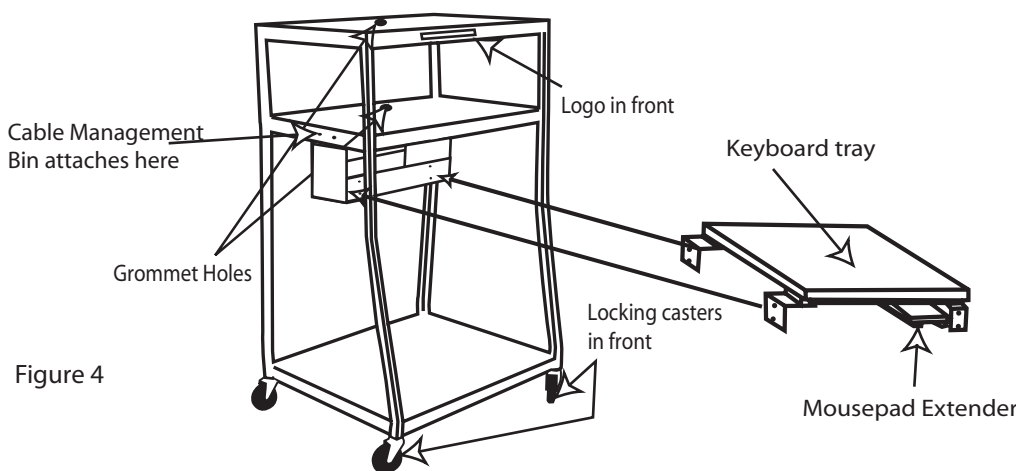

Figure 4

(WEW54IME assembled cart)

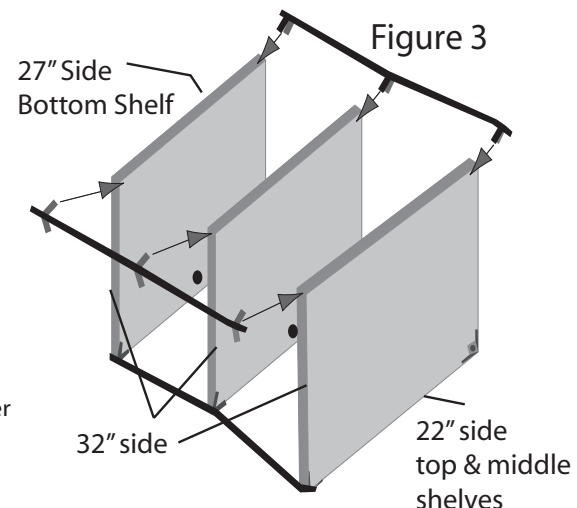

Figure 3