



H. Wilson Company
PO Box 290
Waukegan, IL 60079
Phone: 800-245-7224
Fax: 800-245-8224
www.hwilson.com
sales@hwilson.com

WFLCDM Universal Fixed Height LCD Projector Mount

Parts for WFLCDM

- | | |
|--------------------------------|------------------------|
| (1) ceiling mounting bracket | (4) plastic spacers |
| (1) two-part mounting assembly | (4) arms |
| (1) 6 1/4" threaded pipe | (4) 6mm nuts |
| (4) 6mm shoulder screws | (6) M6 hex head screws |
| (8) 6mm washers | |
| (4) 3" screws + (4) washers | |



Instructions:

1. Secure ceiling mount to ceiling using (4) 3" screws and washers. Place washer on the outside of hole of mounting bracket, then screw in the 3" screw. See Diagram A.

NOTE: Do NOT attach to a drop ceiling.

2. Attach the 6" threaded pipe by screwing into the mounted ceiling bracket. See Diagram A.

3. Attach one part of the mounting assembly to the 6" threaded pipe by screwing it onto pipe, making sure the larger slotted holes are facing in the direction the projector will be facing. See Diagram B.

4. Attach (4) arms to other part of mounting bracket using (4) 6mm shoulder screws & nuts. Do NOT tighten. Determine correct position of arms for projector location and then tighten the (4) nuts. See Diagram C.

5. Connect projector to arms and bracket assembly using screws that are recommended by your installer. Align arm and bracket assembly over the female fittings on your projector. Place nut over female fitting on top of arm. Thread screw through the nut and into the female fitting on the projector. When screw is in place securely, tighten nut. Do not over tighten. **OPTIONAL:** We have provided (4) spacers to prevent marring of LCD surface; to create ventilation where necessary, and to allow level attachment of projector if necessary. See Diagram C or D.

6. Take projector and bracket & arm assembly and attach to mounted pipe assembly by using (4) M6 hexhead screws and washers. Insert the bolt and washer on the outside of the bracket and tighten into the welded nut on the inside of the bracket. Diagram E.

OPTIONAL: For tilting position loosen the (2) bolts in Slot A (See Diagram B) located on side of mounting bracket. Adjust for preferred tilt. Level or up to 10 degree tilt. Tighten bolts when tilt is correct.

8. TO secure the ceiling mounting bracket and mounting assembly, use (2) M6 hexhead screws.

Diagram A



Diagram B

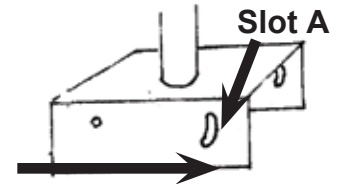

LCD Projector will face in this direction. Note placement of slotted holes.

Diagram C

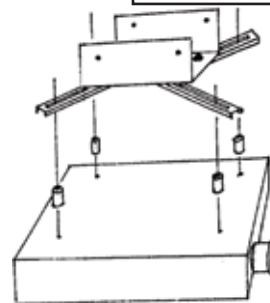

Diagram D

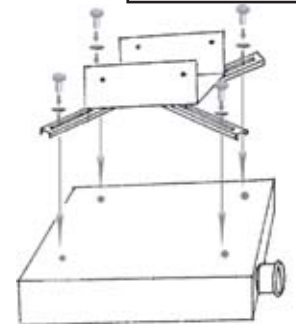
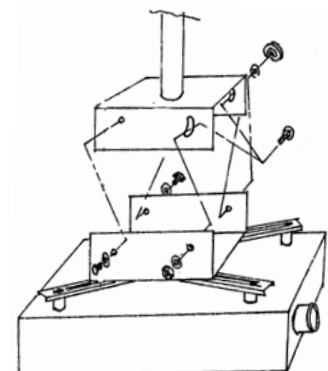

Diagram E



Please have a professional install this H. Wilson Product.