



H. Wilson Company
 555 West Taft Drive
 South Holland IL, 60473
 Phone (800) 245-7224
 Fax: (800)245-8224



Parts for WPSDA Presentation Station

- | | | |
|--------------------------|-------------------------------|-----------------------------|
| 1. (1) Top Platform | 8. (2) Tilting Brackets | 15. (1) Allen Wrench |
| 2. (1) Accessory Shelf | 9. (1) Security Stop (long) | 16. (15) Flat Head Screws |
| 3. (1) Upright Assembly | 10. (1) Security Stop (short) | 17. (4) Wood Screws |
| 4. (2) Foot tubes | 11. (2) Large Knobs | 18. (2) Locking Casters |
| 5. (1) 'T' Shaped Insert | 12. (2) Small Knobs | 19. (2) Non-locking Casters |
| 6. (1) 'L' Shaped Insert | 13. (2) Plastic Caps | 20. (1) Caster Wrench |
| 7. (4) C-Clamps | 14. (2) Plastic Sleeves | |

Instructions

Step 1

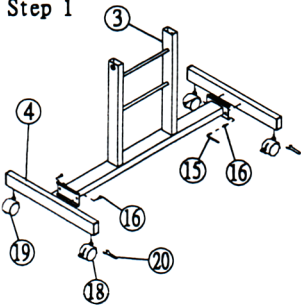

1. Attach one foot tube (#4) to each side of the upright assembly using flat head screws (#16) and the allen wrench (#15). Attach the locking casters (#18) and non-locking casters (#19) to the underside of the foot tubes using the caster wrench (#20).

Step 2

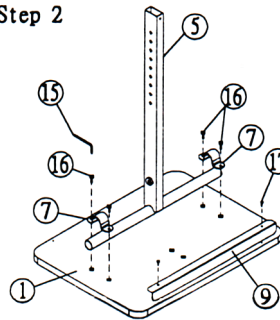

2. Place the Top Platform (#1) facedown. Using two C-clamps (#7) and four Flat head screws (#16), attach the 'T' shaped insert to the top platform. Using two #17 Wood screws, attach the Long Security Stop (#9) to the Top Platform.

Step 3

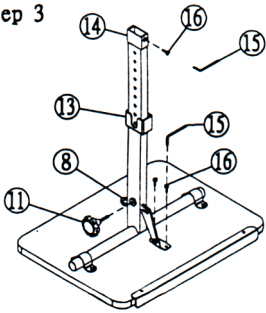

3. Line the Tilting Bracket (#8) up to the remaining pre-drilled holes on the top platform. Attach using #16 screws. Line up opposite end with the hole in the 'T' shaped insert. Secure with Large knob (#11). Slide Plastic Cap (#14) over end of 'T' shaped insert as shown in step 3. Attach Plastic Sleeve to the end of the 'T' shaped insert using a #16 screw.

Step 4

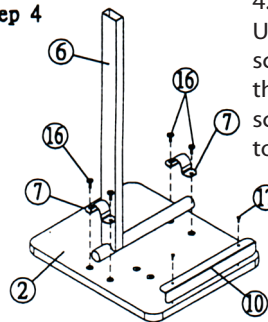

4. Place the Accessory Shelf (#2) facedown. Using two C-clamps (#7) and four flat head screws (#16), attach the 'T' shaped insert to the accessory shelf. Using two #17 wood screws, attach the Short Security Stop (#10) to the accessory shelf.

Step 5

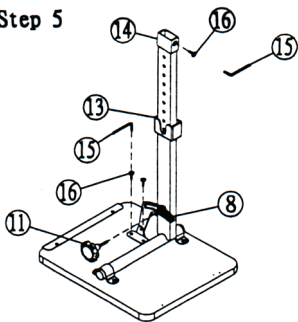

5. Line the Tilting Bracket (#8) up to the remaining pre-drilled holes on the accessory shelf. Attach using #16 screws. Line up opposite end with the hole in the 'L' shaped insert. Secure with Small knob (#12). Slide Plastic Cap (#14) over end of 'L' shaped insert as shown in step 5. Attach Plastic Sleeve to the end of the 'T' shaped insert using a #16 screw.

Step 6

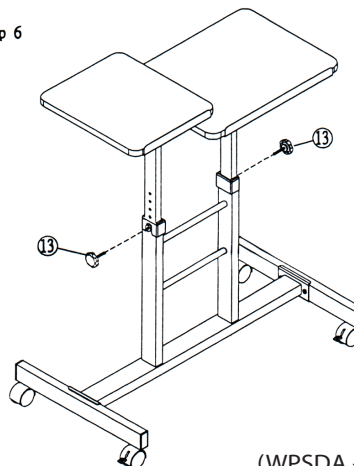

6. Place completed Top shelf unit into Upright Assembly as shown in step 6. Choose desired height and secure using Large knob (#11). Place completed Accessory shelf unit into other side of upright assembly. Choose desired height and secure with small knob (#12).