



H. Wilson Company  
 555 West Taft Drive  
 South Holland, IL 60473  
 Phone: (800) 245-7224  
 Fax: (800) 245-8224  
 sales@hwilson.com

# WPSMS51

## Mobile Flat Panel TV Stand

### Hardware List

A	M8*55 Lag Bolt	4
	φ 8 Washer	8
	M8 Nut	4
B	M8*55 Lag Bolt	4
	φ 8 Washer	4
	M8 Nut	4
C	M6*55 Lag Bolt	2
	φ 6 Washer	2
	M6 Nut	2
D	M5*12 Screw	4
	M5 Nut	4
E	M5*15 Bolt	4
F	M8*75 Lag Bolt	2
	φ 8 Washer	4
	M8 Nut	2
G	M10*30 Allen Screw	2
	φ 10 Washer	2
H	8mm Allen Wrench	1
I	14mm/17mm Wrench	1

### Parts List

J	Base Frame	2 pcs
K	Base Cover	1 pc
L	Upright	1 pc
M	Base/Upright Brackets	2 pcs
N	Shelf	1 pc
O	Shelf Brackets	2 pcs
P	Swivel casters	4 pcs

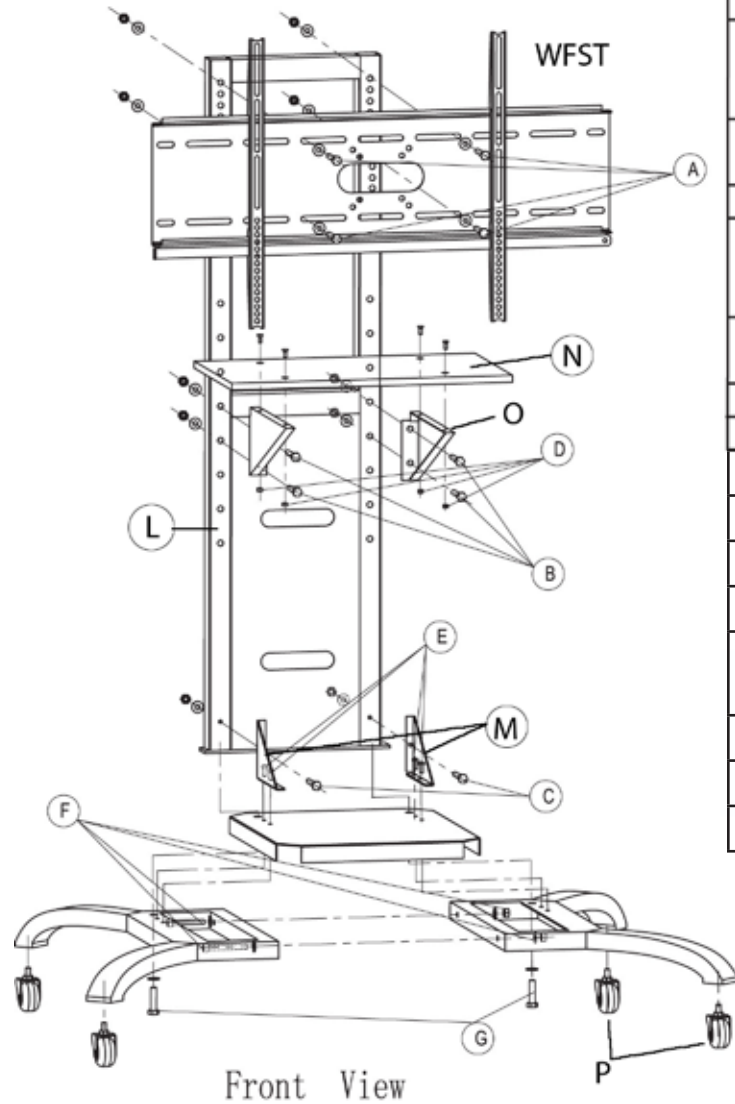

Front View

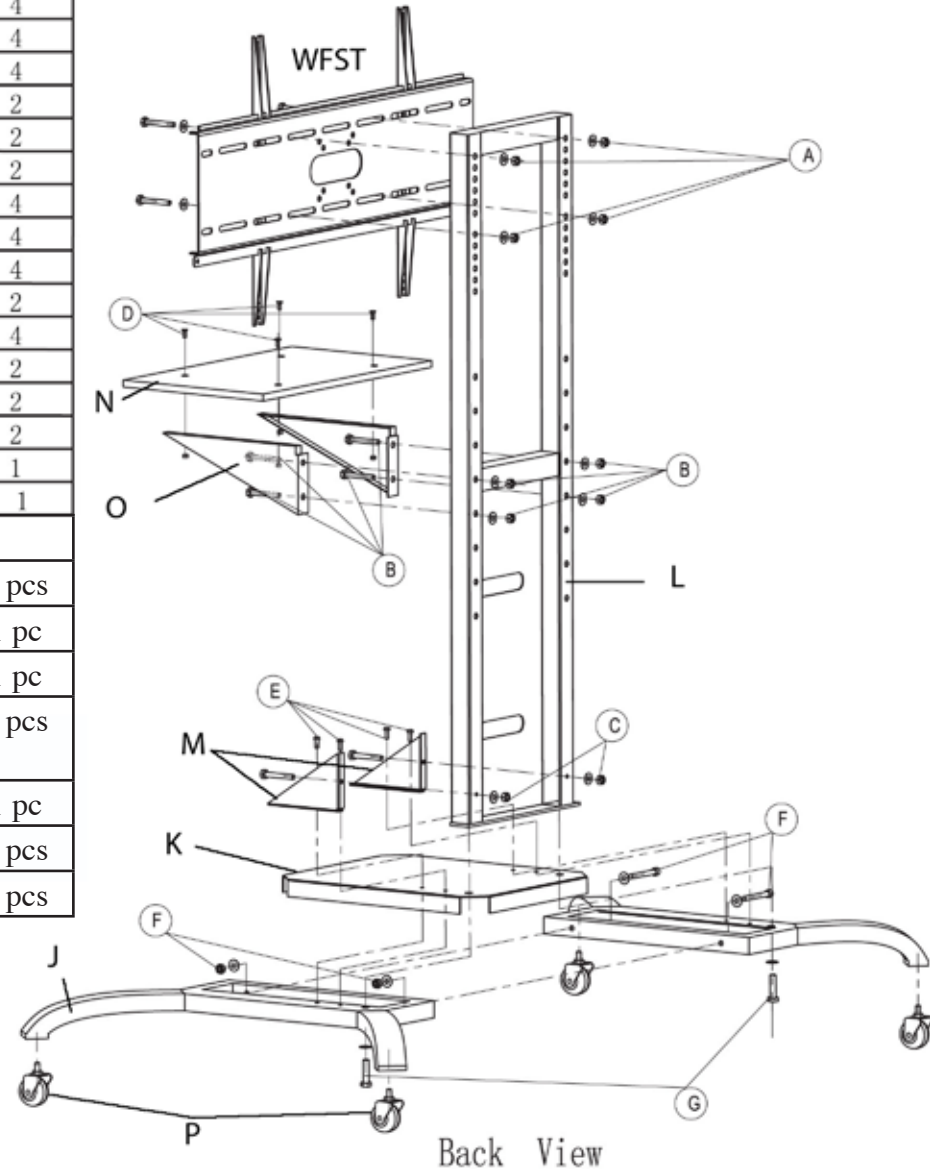

Back View

1. Take part J and assemble using hardware F.
2. Attach Part P to base assembly.
3. Attach part M using hardware E.
4. Place part K on top of base and attach part L using hardware G.

5. Attach part O to upright using hardware B.
6. Attach part N to bracket using hardware D.
7. Attach WFST mount to unit using hardware A.