



**H. Wilson Company**  
 2245 Delany Road  
 Waukegan, IL 60085  
 Phone (800) 245-7224  
 Fax (800) 245-8224

# WPTV50E

## Mobile Plasma Mount

### Parts List:

- A. (1) Top shelf with handle & 4 bosses
  - B. (1) Middle shelf with 8 leg bosses
  - C. (1) Bottom Shelf with caster inserts and four bosses
  - D. (8) Fluted Legs w/channels
  - E. (2) 4" Swivel casters with brake
  - F. (2) 4" swivel casters
  - G. (2) Cabinet Packs
  - H. (1) Base Plate
  - I. (1) WFST Mount
  - J. (2) Chrome Tubes
  - K. (4) 3/8 x 1" Bolt
  - L. (4) 3/8" Washer
  - M. (4) 3/8" Nut
  - N. (1) Upper Bracket
  - O. (4) 5/16" Bolt
  - P. (4) 5/16" Washer
  - Q. (4) 5/16" Nut
  - R. (4) Small Bolt
  - S. Black shelf inlay
- (1) Electrical Assembly if 'E' model was purchased

Required Tools  
(not included)



Rubber Mallet

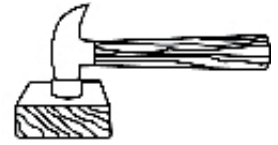

Optional: metal hammer with block of wood to cushion impact.

1. Insert casters into caster sockets, making sure that you have the two locking casters in the caster sockets on the 18" long side of the cart that has the handle.

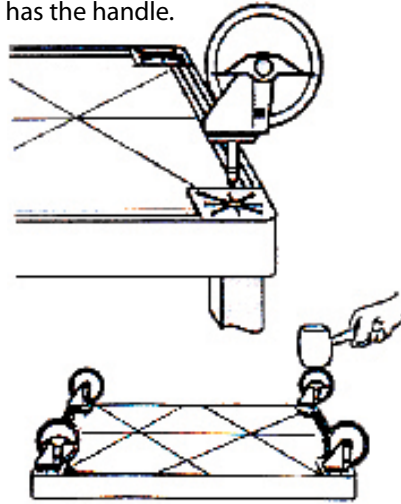

2. Turn shelf so casters are on the floor. Place 16 1/2" fluted legs onto leg bosses. Press fit as much as possible with hands. Seat firmly with rubber mallet.

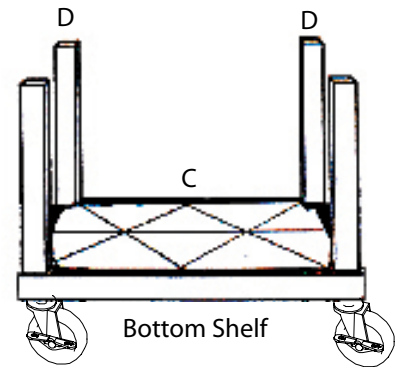

Step 3: Locate back panel and slide down into grooves of the 2 back legs (same side as electrical bracket on top shelf). Take the two side panels, slide into place. Take front panel and slide into place positioned so that the lock will be on the left.

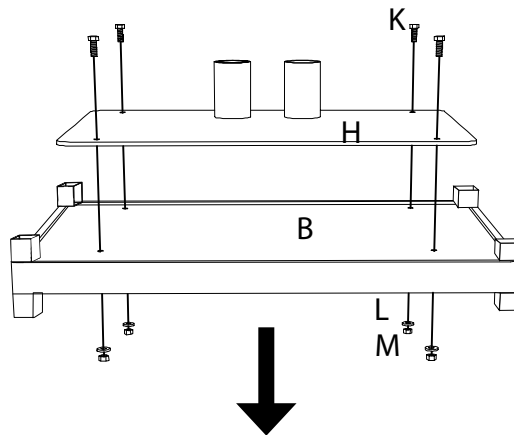
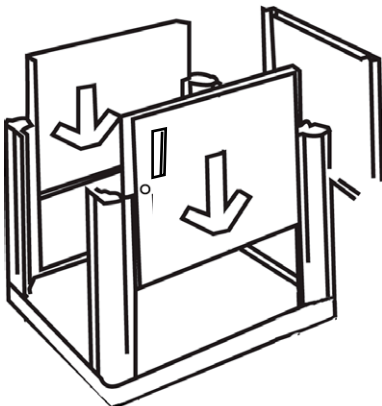

Step 4: Place middle shelf (B) leg bosses into lower fluted legs and press until leg bosses are all the way in (tap gently with mallet if necessary).

Step 5: Place the base plate (H) onto the middle shelf (B) (with the welded tubes at the back of the cabinet). Open cabinet doors. Secure base to shelf with 4 Bolts (K), Washers (L) and Nuts (M).

Step 6: Repeat fluted leg steps.

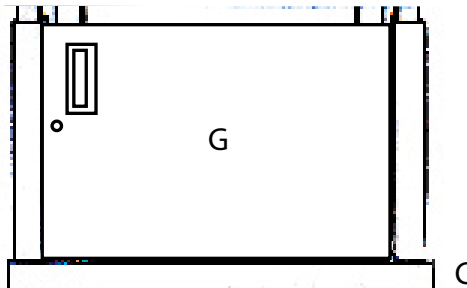

Shown without cabinet and legs for clear view

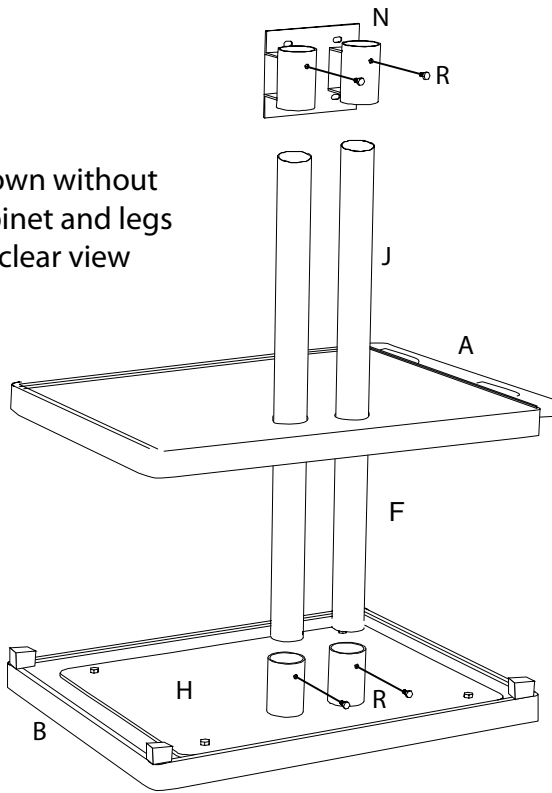

Step 7: Insert the two chrome tubes (J) into the welded cups on the base (H). Secure with 2 Small bolts (R).

Step 8: Locate back panel and slide down into grooves of the 2 back legs. Take the two side panels, slide into place. Take front panel and slide into place positioned so that the lock will be on the left.

Step 9: Line the holes in the Top Shelf (A) up with the chrome poles. Lower top shelf until the bosses are in the fluted legs. Tap gently in place. Lower inlay over poles onto the top shelf.

Step 10: Insert upper bracket (N) onto the chrome poles and secure in place with two small bolts (R)

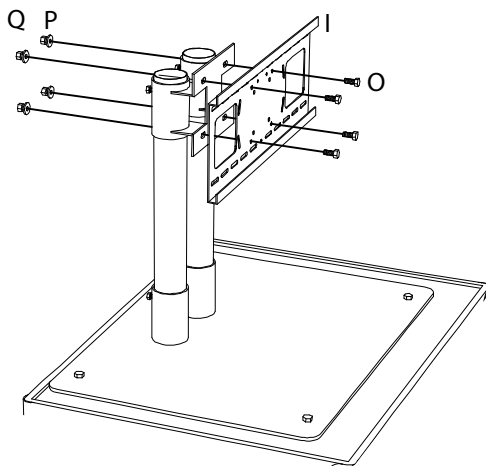

Step 11: Attach WFST mount (I) to upper bracket and secure in place with Bolts, nuts and washers (O, P & Q)

TV Mounting Instructions are included with the WFST mount.

Electrical assembly mounting instructions are included with the assembly.

