



H. Wilson Company  
 2245 Delany Road  
 Waukegan, IL 60087  
 (800) 245-7224  
 sales@hwilson.com

# WT26C, WT34C, WT42C & WT2642C Tuffy Cart Assembly Instructions

### Parts List:

- (1) Top shelf with handle & 4 bosses
- (1) Middle shelf with 8 leg bosses
- (1) Bottom Shelf with caster inserts and four bosses
- (1) Electrical Assembly if 'E' model was purchased
- (4) 8 1/2" Legs

- (4) 16 1/2" legs
- (4) 16 1/2" fluted legs
- (3) Cable Management Clips not on WT26CE Model)
- (2) 4" Swivel casters with brake
- (2) 4" swivel casters
- (1) Cabinet Pack

Required Tools  
 (not included)



Rubber Mallet

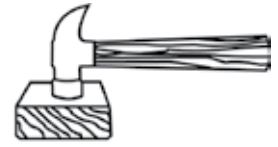

Optional: metal hammer with block of wood to cushion impact.

TO MAKE A	ASSEMBLED HEIGHT	USE THESE LEGS	USE THESE SHELVES
WT26C	24 1/2"	16 1/2" fluted	TOP & BOTTOM
WT34C	34"	1 SET 8 1/2" & 16 1/2" fluted	TOP, MIDDLE & BOTTOM
WT42C	42 1/2"	1 SET OF 16 1/2"/1 SET OF 16 1/2" fluted	TOP, MIDDLE & BOTTOM

**\*\*\*NOTE: Fluted legs should be placed over bosses with the fluted channels towards each other, facing in.**

1. Place top shelf on firm surface, underside up. For WT34 use 8 1/2" legs at this time. For WT42, use 16 1/2" legs at this time. For a WT26, use 16 1/2" fluted legs. Insert legs onto leg bosses. Press fit as much as possible with hands. Tap firmly with rubber mallet if necessary.

2. If making a WT26, your table has no middle shelf, please proceed to step 4. Otherwise, position middle shelf, underside up, onto legs. Press fit as much as possible with hands. Using rubber mallet, firmly seat legs into shelf.

3. FOR WT34 & WT42 ONLY - Place 16 1/2" fluted legs onto leg bosses. Press fit as much as possible with hands. Seat firmly with rubber mallet

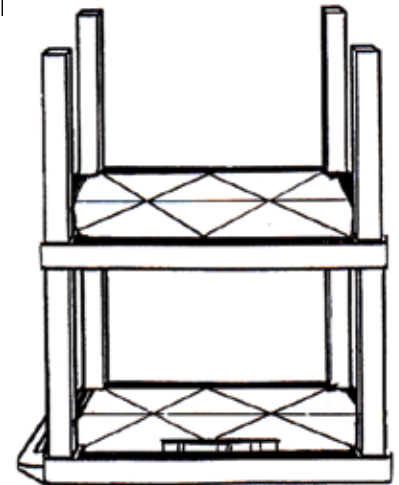
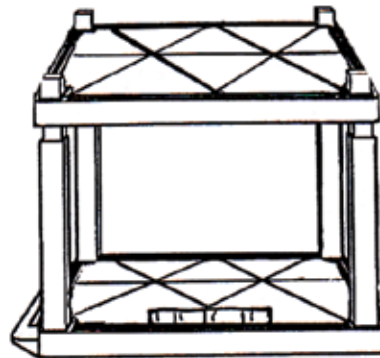
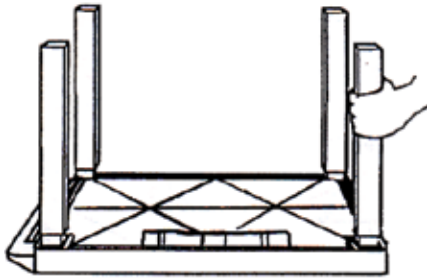

Step 4: Locate back panel and slide down into grooves of the 2 back legs (same side as electrical bracket on top shelf). Take the two side panels, slide into place. Take front panel and slide into place positioned so that the lock will be on the left.

5. Position bottom shelf, underside up, onto legs. Firmly seat shelf onto legs using rubber mallet.

6. Insert casters into caster sockets, making sure that you have the two locking casters in the caster sockets on the 18" long side of the cart that has the handle.

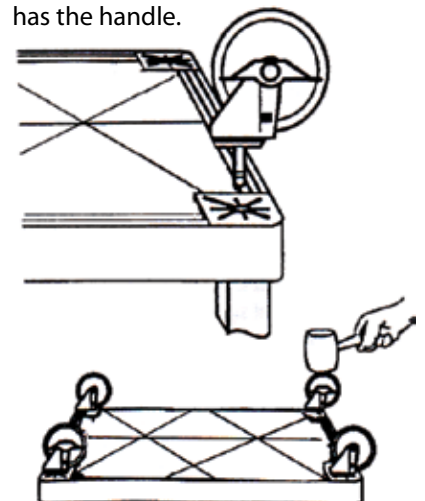
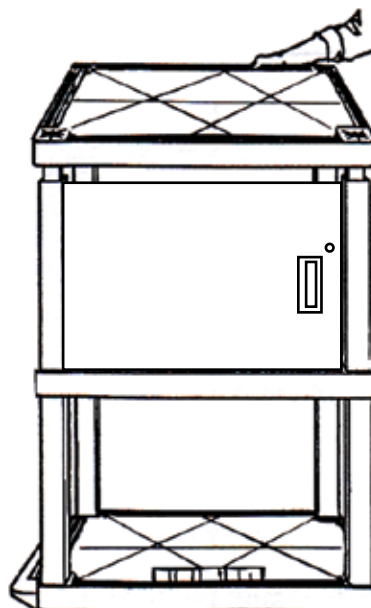
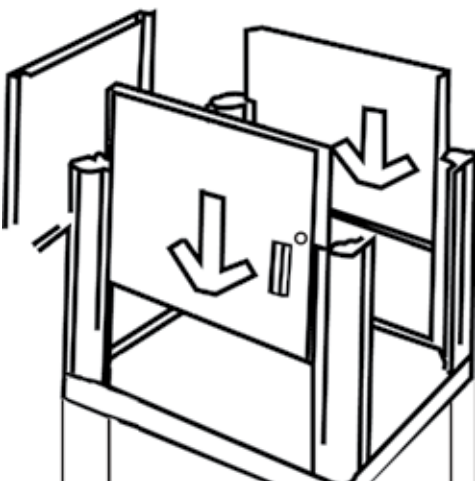

To attach the electrical assembly, please see the instructions included with the assembly.