



H. Wilson Company
 2245 Delany Road
 Waukegan, IL 60087
 (800) 245-7224
 sales@hwilson.com

WTMSHE

Required Tools
 (not included)



Rubber Mallet

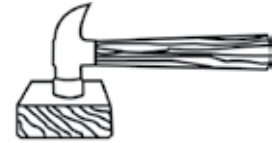

Optional: metal hammer with block of wood to cushion impact.

Parts List:

- (1) Top shelf with handle & 4 bosses
- (1) Middle shelf with 8 bosses (up & down)
- (1) Bottom Shelf with caster inserts and leg cutout
- (1) Electrical Assembly
- (8) Square Legs
- (2) 4" Swivel casters with brake
- (2) 4" swivel casters

1. Follow **CASTER** Instructions
2. Follow **LEG** Instructions to bottom shelf
3. Follow **MIDDLE shelf instructions**
4. Follow **TOP SHELF** instructions
5. Follow **CPU holder** instructions (in CPU Holder box)
6. Follow **Electrical assembly** instructions (in bag with electrical)



CASTER

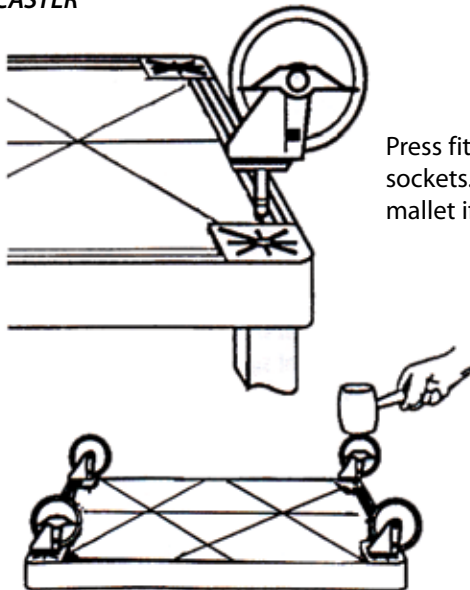

Press fit casters into caster sockets. Tap gently with mallet if necessary.

LEG (Onto Bottom OR Middle Shelf)

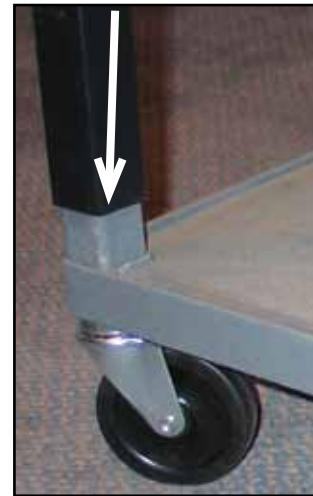

(Bottom) Turn over shelf (shelves).
 (Any) Press fit legs over bosses. Gently tap with mallet if necessary.

MIDDLE SHELF

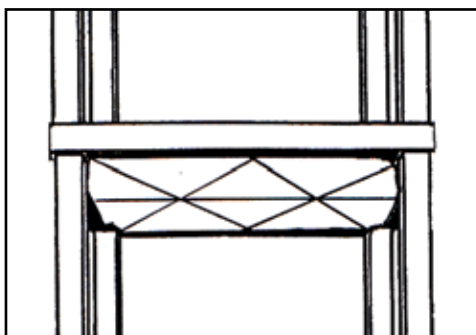

Middle shelves have 8 bosses. Place the bosses on the underside (ribbed) into the top of the lower legs. Press fit first and tap with mallet if necessary. Place legs onto upper bosses - tap with mallet if necessary

TOP SHELF

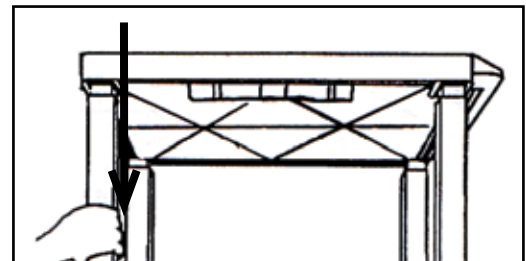

Press fit into the top of the final set of legs. Tap gently with mallet to fully seat.

***** Final Steps - Attach Electrical Assembly To Molded Bracket As Shown In Packaged Instructions
 Attach CPU Clamp holder as shown in the packaged instructions**