



**H. Wilson Company**  
2245 Delany Road  
Waukegan, IL 60087  
Phone: 800-245-7224  
www.hwilson.com  
sales@hwilson.com

## **WTPS70(E)** **Presentation Station** **Multimedia Workstation**

### **Parts List**

- (1) Top Shelf with handle (18" x 24")
- (1) Middle Shelf (18" x 24")
- (1) Bottom Shelf with caster sockets (18" x 24")
- (1) Upper Shelf (18" x 12")
- (1) Middle Shelf (18" x 12")
- (1) Lower Shelf with caster sockets (18" x 12")
- (1) Sets of fluted legs (4 each set)
- (12) Straight legs
- (4) 1 1/2" bolts, nuts & washers
- (2) 3 1/2" bolts, nuts & washers
- (6) 4" Swivel Casters
- (1) Electrical Assembly (if ordered)



### **SHELF ATTACHMENT**



The shelves need to be bolted together as shown in photo.

1. Match up shelves. Bottom shelves have caster sleeves. Line up holes and bolt together with enclosed hardware. Middle shelves have leg bosses on both upper and lower parts of shelves. Line up holes and bolt together with enclosed hardware. Top 18" x 24" shelf has the molded handle. Top 18" x 12" shelf has 2 bosses on the underside only. Line up holes and bolt together with enclosed hardware.

2. Turn bottom shelf set to expose caster sleeves. you have 6 casters. where the shelves are joined, place one non locking caster on one side and one on the other side of the join.

Tap remaining casters into place until fully seated.

### **CASTER**

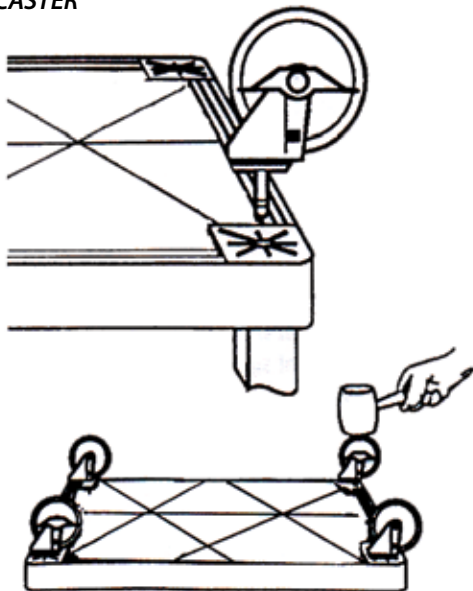

Required Tools  
(not included)



Rubber Mallet

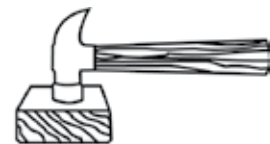

Optional: metal hammer with block of wood to cushion impact.

**LEG (Onto Bottom OR Middle Shelf)**

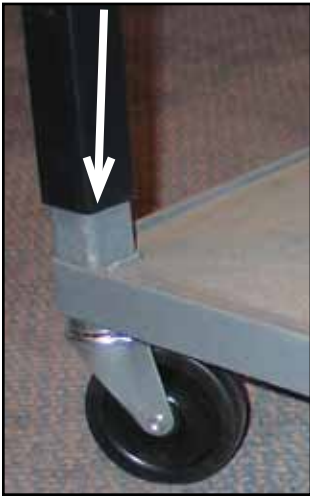

(Bottom) Turn over shelf (shelves).  
(Any) Press fit legs over bosses. Gently tap with mallet if necessary.

**MIDDLE SHELF ASSEMBLY**

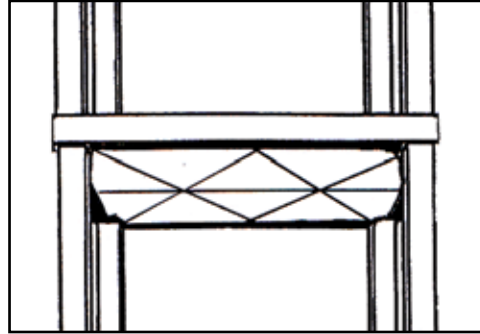

Middle shelf set will have 12 bosses, six up & six down. Place the bosses on the underside (ribbed) into the top of the lower legs. Press fit first and tap with mallet if necessary

Place remaining legs onto remaining bosses.

**KEYBOARD TRAY**



Follow instructions included in Keyboard tray package

**TOP SHELF**

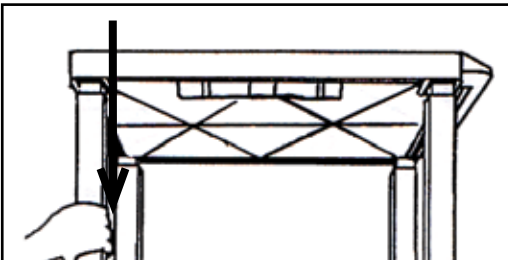

Press fit into the top of the final set of legs.  
Tap gently with mallet if necessary to fully seat.

**\*\*\* Final Step For all - Attach Electrical Assembly To Molded Bracket As Shown In Packaged Instructions**