



Specialty Furniture & *Mounting Systems*

Rolling Out Over 30 New Products for 2008!



Audio Visual Tables

LCD Mounts

Plasma Mounts

Projector Mounts

Computer Workstations

Multi-Media Workcenters

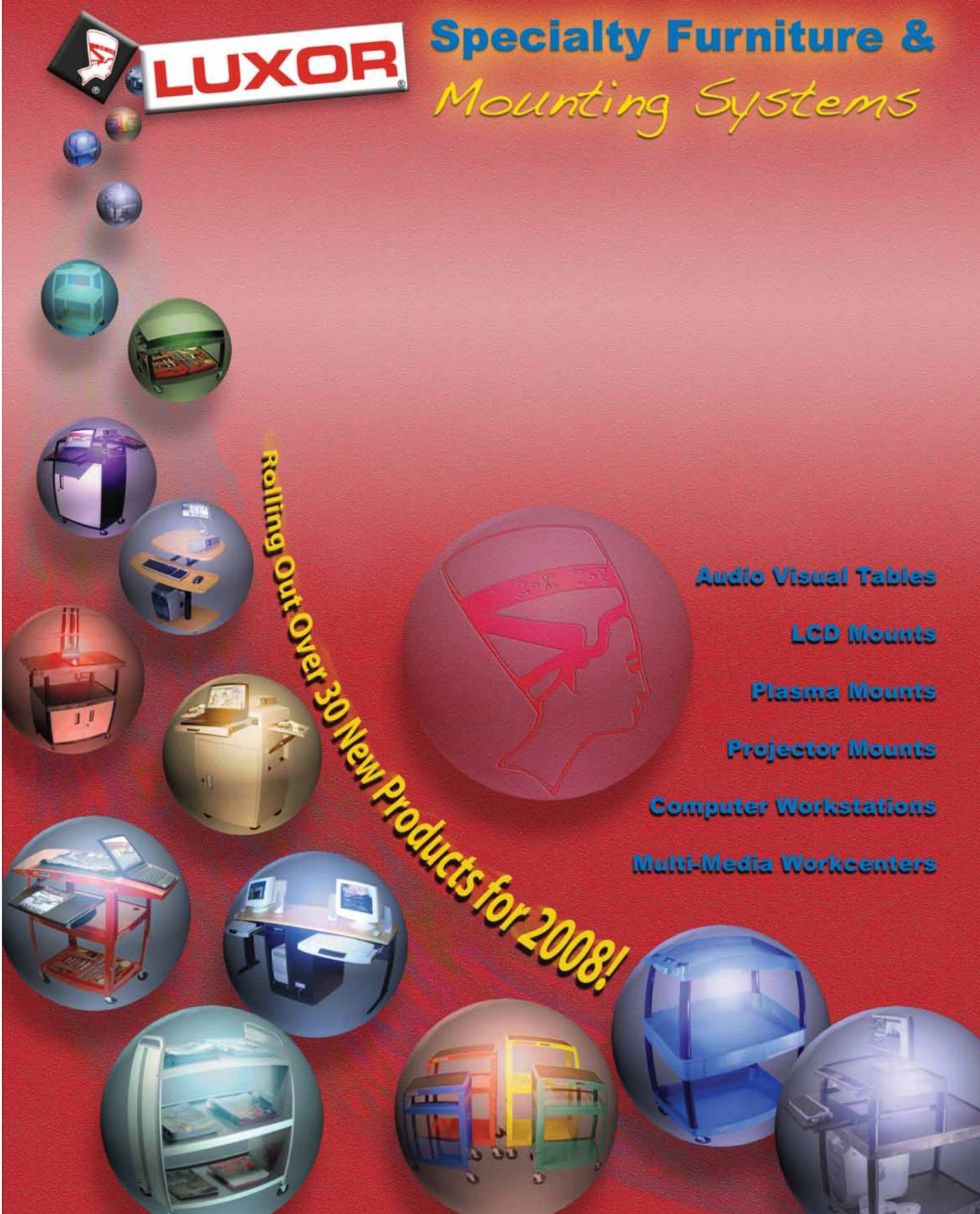

New Products



MRC S1 • All steel construction, available in two sizes. Page 46



MRC W2 • All steel wire construction, available in two sizes. Page 46



MRC W2 • Stainless steel tub cart. Available in two sizes. Page 46

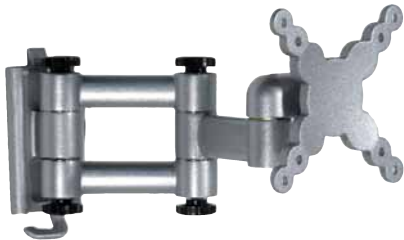

LXUA1330L • Swing out LCD display mount. Page 6



LXUF133L • LCD display flat wall mount. Page 6



LXUT1330L • LCD display tilt mount. Page 6



LXUT3760 • LCD or Plasma universal tilt mount. Available in two sizes. Page 6

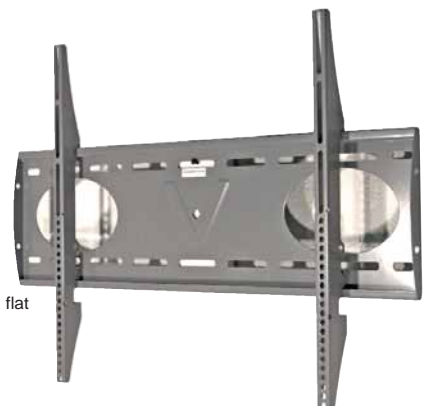

LXUF3760 • LCD or Plasma universal flat mount. Available in two sizes. Page 6

for 2008-2009!

Luxor's new Prestige Series



PS3144 • Adjustable height wood & steel lectern. Page 56



PS3800 • Mobile wood & steel lectern. Page 56



PS2633 • Adjustable height and tilt projector table. Page 56



PS3945 • Adjustable height mobile computer workstation. Page 16



MRCS1 • 3-shelf multi-media workstation with pull-out keyboard/laptop shelf. Page 16

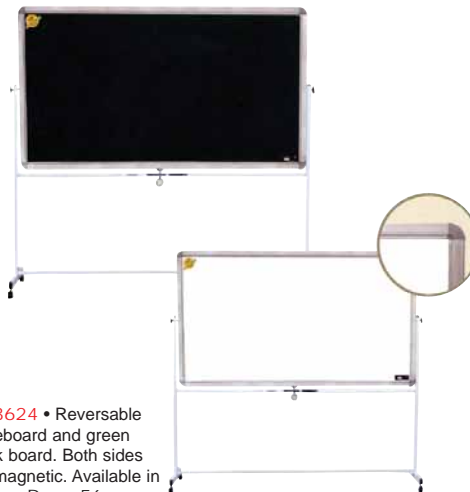

MB3624 • Reversible whiteboard and green chalk board. Both sides are magnetic. Available in 4 sizes. Page 56



STC & TC Tub Carts • Tub and flat shelves are now available in 6 colors for TC and STC tub carts. Legs are now available in 9 colors for TC and STC tub cars. Page 52



LCD20 • children's desk with wood top and steel frame. Available in two colors. Page 36

LKCP15 • Plastic chair available in 5 colors and 5 sizes. Page 36





2008 - 2009

Luxor is committed to providing high-quality, cost effective furniture that improves efficiency, enhances performance and increases productivity. All luxor products meet the highest standards of quality making them durable and reliable. This assurance of quality is backed-up by a lifetime guarantee on every product sold.

Fast Facts - Under every product picture you will find basic information such as: model name, dimensions, weight and price (for priced version of catalog).



Luxor warehouses all of our product and ships promptly. Speedy delivery keeps customers happy!

Most Products Ship UPS

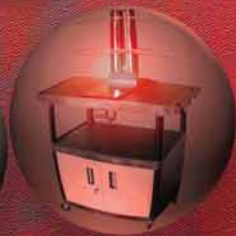
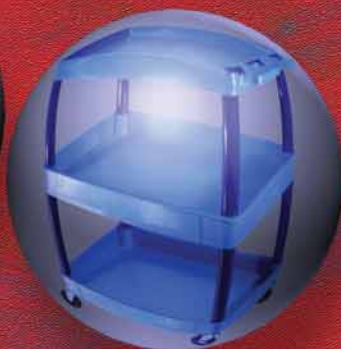



Mounting Systems

New Mounts	6
Projector Mounts	7
Mobile Plasma Mounts	8
Plasma TV Mounts	10
Economount TV Mounts	12
LCD Monitor Mounts	15

Table of Contents

Computer Workstations

New Computer Workstations	16
Laptop/Presentation Workstations	17
Multi-Media Workstations	20
Multi-Function Endura Tables	21
Children's Workstations	22
Endura Computer Workstations	23
Economical Hi-Tech	27
Adjustable Height Workstations	28
Modern Computer Workstations	29
Modern Style Workstations	30
Versatile Computer Workstations	31
Computer Security Centers	32
Multi-Media Workstations	33
Steel Computer Workstations	34

Hi-Tech

New Hi-Tech	36
Versatile Workcenters	37
Hi-Tech Computer Workstations	38
Computer Centers	39
While Supplies Last	45

Multi-Purpose

New Multi-Purpose	46
Stainless Steel Carts	47
Wire Carts/Packing Station	48
Janitorial Carts	49
Bussing/Serving Carts	50
General Purpose Carts	51
Color STC & TC carts	52
Tub Carts	54

Audio/Visual

New Audio Visual	56
Steel Overhead Tables	57
Endura Overhead Tables	58
Duraweld Tables	60
Steel Adjustable Height Tables	61
Video Tables	62
Large Screen Monitor Tables	65
Universal Table Accessories	66
Endura Equipment Tables	67
Endura Editing Production Centers	70
Endura Video Consoles	67
Low Priced Plastic Tables	72
White Boards	74
Easels	75
Lecterns	76

Storage Systems

Display Racks	78
Library Book Trucks	80



New Mounts!

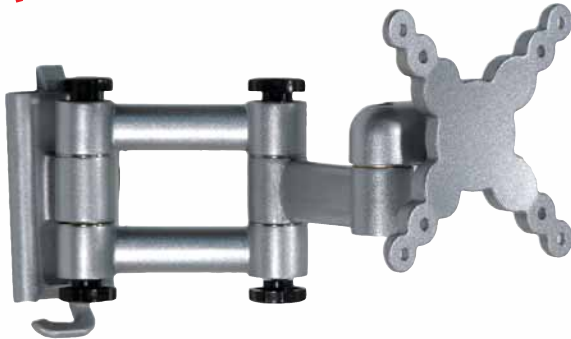

LXUA1330L - Designed to fit displays up to 30 inches, the Swingout Arm mount is a top choice for mounting LCD displays in locations where having viewing flexibility is a priority. The swingout design allows consumers to pull displays up to ten inches away from the wall and retract to less than four inches in depth. Additionally, the mount has a maximum tilt range of 20 degrees and can be swung left or right 180 degrees. VESA 75/100 mm compatible, the mount incorporates a snap-in design for easy installation. \$80



LXUT1330L - Ideal for placing 13 to 30-inch LCD displays in locations where adjustments are necessary, the LCD Tilt Mount has a maximum tilt range of 20 degrees up or down. The VESA 75/100 mm compatible mount holds the LCD display less than four inches from the wall. This mount is a great solution for many difficult display placements. \$40



LXUF1330L - Designed to fit LCD displays up to 30 inch, the LCD Flat Wall Mount is perfect for mounting displays in any room in the house. The spacesaving design holds the display two inches from the wall and is VESA 75/100 mm compatible. With an easy snap-in design and built-in cable management system this mount is an ideal solution for many situations. \$30



LXUT3760 - Available in models to fit 26 to 37 inch (**LXUT2637**) or 37 to 60 inch (**LXUT3760**) LCD and plasma displays, the Universal Tilt Mount is designed for mounting displays above eye-level. Holding the display three inches from the wall, the mount has a maximum tilt range of 15 degrees up or down. These mounts also feature a built-in level for easy installation and lateral shift adjustment capabilities. \$150

LXUT2637 - Fits 26" - 37" monitors. \$130

LXUF3760 - With two models to select from, the Universal Flat Mount fits 26 to 37 inch (**LXUF2637**) and 37 to 60 inch (**LXUF3760**) LCD and plasma displays, and is suited for the majority of home entertainment situations. Ideal for mounting displays for eye-level viewing, the Universal Flat Mount holds displays less than one inch from the wall. Also features a lift and hook design, safety lock and lateral shift adjustment capabilities. \$100

LXUF2637 - Fits 26" - 37" monitors. \$80

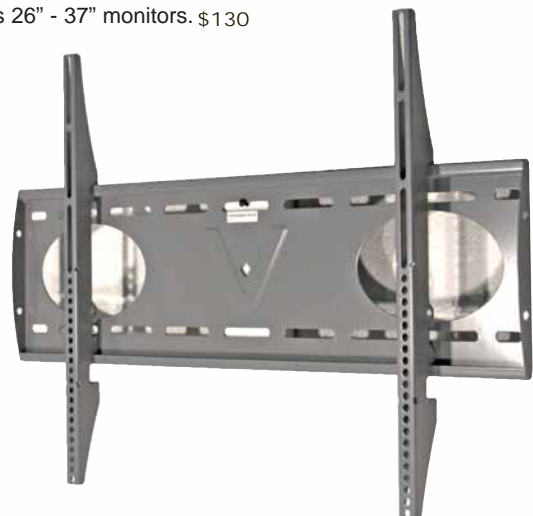

Mounting Systems

Projector Mounts



LLPMS • 27 $\frac{1}{2}$ " - 46 $\frac{1}{4}$ " long • 8 Lbs.

\$258



LSPM • 18" - 30" long • 15 Lbs.

\$218

LLPMS - Universal projector mount with an adjustable tilt upwards and downward 0-10 degrees. Mast, telescopes 27 $\frac{1}{2}$ "-46 $\frac{1}{4}$ " from the ceiling. Mounting plate included. Wt. 8 lbs. Black glossy powder coat paint finish.

LSPM - Universal small projector mount rotates 360°. Holds most 10" - 21" LCD projectors. Adjustable tilt 0° to 10°. Opens from 7" to 14" (left to right). Opens from 3" to 5.75" (top to bottom). 8 point clamping mechanisms adjust from 6.5" - 10" (front to back). Mast telescopes 18" - 30" from ceiling. Integrated flush mount plate included. Load capacity 75 lbs. Wt. 15 lbs. Black powder coat paint finish.



LXPBL • 9" - 12 $\frac{1}{2}$ " long • 10 Lbs.

\$275

Shown with LXPBL projector mount (sold separately).



LXAPL • 26" - 47" long • 8 Lbs.

\$144

LXPBL - Universal projector mount, rotates 360 degrees, with an adjustable upward and downward 0-20 degree tilt and is an easy installation with a low-profile and cable channel enclosure. Wt. 10 lbs.

LXAPL - Adapter kit for the LXPBL allowing for adjustable extension lengths from 26"-47" continuing the channel enclosure for holding the cables while providing that clean look. Wt. 9 lbs.

LXSCS - Dual-Cable security system providing safety and security. Protecting the mounting points on the chassis and the two installation mounting points of wall or ceiling. Wt. 2 lbs.

LVDH - Wall mount brackets for VHS/DVD recorders, CD players, digital cable receivers, and HD receivers. For your convenience, brackets are stackable to create a tower effect. The mounting ring tray extends 12" from the wall and has a load capacity of 25 lbs. Wt. 5 lbs. Black glossy powder coat finish.



LXSCS • Security Cable • 2 Lbs.

\$77

Unit can be stacked to hold multiple devices!
(Note: TV is shown on TV wall mount, do not exceed 25 lb. load).



LVDH • Extends 12" From Wall • 5 Lbs.

\$41

ALL LUXOR PRODUCTS
QUICK-SHIP

Mounting Systems

LE27WTUD - 42" wide top cart with built in plasma/LCD mount that can accommodate up to a 50" screen. Middle shelf is 32"W x 24"D. All shelves are reinforced with two aluminum bars for added strength. Molded plastic shelves will never dent, rust or stain. Includes 3-outlet surge suppressing electric with 15' cord.

LE40WTUD - 42" wide top cart with built in plasma/LCD mount that can accommodate up to a 50" screen. Middle and bottom shelves are 32"W x 24"D. All shelves are reinforced with two aluminum bars for added strength. Molded plastic shelves will never dent, rust or stain. Includes 3-outlet surge suppressing electric with 15' cord.

LE48WTUD - 42" wide top cart with built in plasma/LCD mount that can accommodate up to a 50" screen. Middle and bottom shelves are 32"W x 24"D. All shelves are reinforced with two aluminum bars for added strength. Molded plastic shelves will never dent, rust or stain. Includes 3-outlet surge suppressing electric with 15' cord.

LEB54WTUD - 42" wide top cart with built in plasma/LCD mount that can accommodate up to a 50" screen. Middle and bottom shelves are 32"W x 24"D. All shelves are reinforced with two aluminum bars for added strength. Molded plastic shelves will never dent, rust or stain. Includes 3-outlet surge suppressing electric with 15' cord.



LE27WTUD • 42"W x 24"D x 27"H • 82 Lbs. \$786



LE40WTUD • 42"W x 24"D x 40"H • 99 Lbs. \$866

WTUD



LE48WTUD • 42"W x 24"D x 48"H • 99 Lbs. \$860



LEB54WTUD • 42"W x 24"D x 54"H • 99 Lbs. \$869



LE27CWTUD • 42"W x 24"D x 27"H • 114 Lbs. \$927



LE40CWTUD • 42"W x 24"D x 27"H • 129 Lbs. \$988

CWTUD



LE48CWTUD • 42"W x 24"D x 27"H • 129 Lbs.\$992



LEB54CWTUD • 42"W x 24"D x 27"H • 129 Lbs.\$998

LE27CWTUD - 42" wide top cart with built in plasma/LCD mount that can accomodate up to a 50" screen. Middle shelf is 32"W x 24"D. All shelves are reinforced with two aluminum bars for added strength. Molded plastic shelves will never dent, rust or stain. Includes 3-outlet surge suppressing electric with 15' cord and locking steel cabinet.

LE40CWTUD - 42" wide top cart with built in plasma/LCD mount that can accomodate up to a 50" screen. Middle and bottom shelves are 32"W x 24"D. All shelves are reinforced with two aluminum bars for added strength. Molded plastic shelves will never dent, rust or stain. Includes 3-outlet surge suppressing electric with 15' cord and locking steel cabinet.

LE48CWTUD - 42" wide top cart with built in plasma/LCD mount that can accomodate up to a 50" screen. Middle and bottom shelves are 32"W x 24"D. All shelves are reinforced with two aluminum bars for added strength. Molded plastic shelves will never dent, rust or stain. Includes 3-outlet surge suppressing electric with 15' cord and locking steel cabinet.

LEB54CWTUD - 42" wide top cart with built in plasma/LCD mount that can accomodate up to a 50" screen. Middle and bottom shelves are 32"W x 24"D. All shelves are reinforced with two aluminum bars for added strength. Molded plastic shelves will never dent, rust or stain. Includes 3-outlet surge suppressing electric with 15' cord and locking steel cabinet.

Mounting Systems

Plasma TV Mounting Systems

Innovative Universal Plasma Mounts determine which mounting configuration is needed for which plasma display. Utilizing the adjustable mounting tray and the unique slotted rail system, any plasma display with a square or rectangular mounting hole pattern, can be accommodated.

LUPM - Universal plasma wall mount is a multi-configurable mount with a single arm, double arm articulating or near flush mount. Parts are provided. Holds all 40" - 50" plasma displays with a square or rectangular mounting hole pattern. Adjustable tilt 0°-10°. Mount rotates 240° at monitor, 160° at the wall, and 240° at the elbow joint (double arm configuration). Load capacity 130 lbs. Mounting assembly included. Wt. 42 lbs. Silver powder coat paint finish.

LUPMW - Universal plasma wall flush mount holds all 40" - 50" plasma displays with a square or rectangular mounting hole pattern. Distance from wall to back of mount is 3¼". Load capacity 130 lbs. Mounting assembly included. Wt. 29 lbs. Silver powder coat paint finish.

LUPMC - Universal plasma ceiling mount holds all 40" - 50" plasma displays with a square or rectangular mounting hole pattern. Mast telescopes 18" - 30" from ceiling. Mount rotates 360° and has adjustable tilt 0° - 10°. Mount can accommodate a second plasma display. Load capacity 130 lbs. Mounting assembly included. Wt. 30 lbs. Silver powder coat paint finish.

LUMA - Universal mounting assembly included with all plasma mounts. Silver powder coat paint finish.

LUD3 - Fixed mount with lift and lock installation for plasma or LCD monitors. Includes mounting guide, locking system, and complete mounting hardware kit. Fits 32" - 60" flat panel displays up to 200 lbs. Silver finish.

LUD2 - Tilt mount with lift and lock installation for plasma or LCD monitors. Tilts from 15° to -5°. Includes mounting guide, locking system, and complete mounting hardware kit. Fits 23" - 37" flat panel displays up to 80 lbs. Silver finish.

Multi-Configurable!

Choose to mount using the double arm, single arm, or near flush configuration.

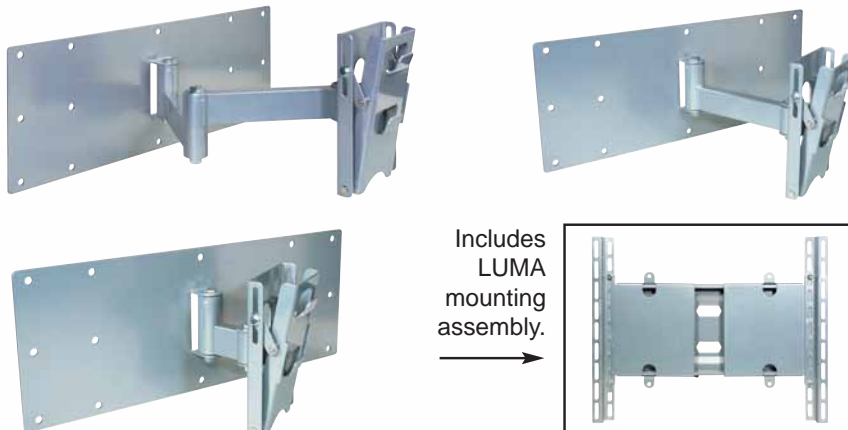

Includes
LUMA
mounting
assembly.

LUPM with LUMA • Holds 40" - 50" Plasma • 130 Lb. Capacity • 0°-10° Tilt • 42 Lbs.

\$189

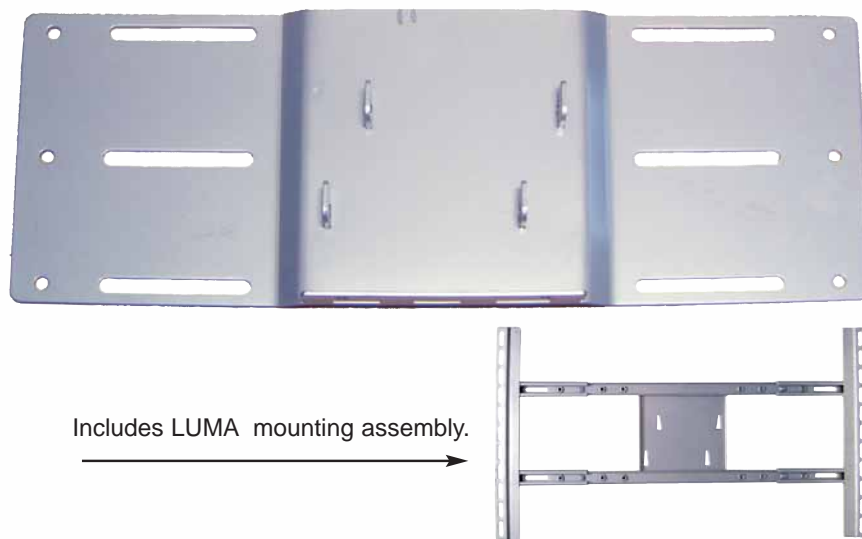

Includes LUMA mounting assembly.

LUPMW with LUMA • Holds 40" - 50" Plasma • 130 Lb. Capacity • 29 Lbs.

\$149



Includes LUMA
mounting assembly.

LUD3 • 31½"W x 1½"D x 21"H • 6 Lbs.

\$119



LUPMC w/LUMA • 18" - 30" long • 30 Lbs. \$169

LUD2 • 8½"W x 1½"D x 14½"H • 5 Lbs. \$94

ALL LUXOR PRODUCTS
QUICK-SHIP

Mounting Systems

Plasma TV Mounting Systems



LUPMWX • Holds 32"-63" Plasma • 22 Lbs. \$301



LUPMSS • For 30", 42" & 60" Plasma \$172

LUPMWX - Universal plasma wall mount supports almost any 32"-63" plasma display. Universal brackets easily hook onto the mount bars for fast installation. Adjustable 15° forward tilt, 5° backward tilt with one touch effortless screen positioning. Tilt can be locked into place if necessary. Load capacity 185 lbs. Wt. 22 lbs. Black glossy powder coat paint finish.

LUPMSS - Universal plasma single stud wall mount. Features heavy steel construction and 10° tilt. TV's can be attached flush to wall or with a 10° tilt. Available for 30", 42" and 60" plasma and flat panel TV's. Includes hardware for flat and 10° tilt mounting to plasma stand. Black glossy powder coat paint finish.

LUFMPRC - This plasma floor mount integrates exceptionally well with its unique style holding your 37" to 50" plasma displays. Fully adjustable to a 72" height and the casters provide the mobility you need to cover multiple locations. Wt. 80 lbs. The base is 26³/₄"W x 25¹⁷/₃₂"D x 6¹/₂"H.

LUFMPRG - Same as above with leveling floor glides instead of casters.

LDDFS68 - Mobile plasma or LCD floor stand. Perfect for presentation or digital signage environments. Locking casters allow for easy mobility and secure placement when needed. Cables can be routed through chrome poles. Base is shaped so that it can be nested with other units for easy, compact storage. Maximum load 160 lbs. To be used with LXRTM (below) or LXCTM2 (page 13) mounting assemblies. 68" high.

LDDFS80 - Same as above with a height of 80".

LXCTM2 - Universal plasma mount holds 37"-50" plasma displays in a horizontal position and allows for 2 degree tilt. The LXCTM is used in conjunction with the LUFMPRC and LUFMPRG. Wt. 28 lbs.

LXCTM1 - Same as above, hold plasma displays up to 32". Wt. 22 lbs.

LXPSD - 20"W x 16"D shelf accessory for VHS/DVD player, CD player, digital cable and HD receiver. This accessory is used in conjunction with LUFMPRC. Black color.



Shown with LXCTM2 mounting assembly, sold separately. (see below).

LUFMPRC • 26³/₄"W x 25¹⁷/₃₂"D x 72"H • 80 Lbs. \$780

Shown with LXRTM mounting assembly. Rotates 360°! (sold separately)



LDDFS68 • 27³/₄"D x 68"H • 63 Lbs. \$711

LUFMPRG • Same w/glides instead of casters. \$684

LDDFS80 • 27³/₄"D x 80"H • 67 Lbs. \$776



LXCTM2 • Used With LUFMPRC • 28 Lbs. \$283



LXCTM1 • Used With LUFMPRC • 22 Lbs. \$283

LXPSD • Used With LUFMPRC • 20"W x 16"D \$149

Mounting Systems

Economount TV/VCR Mounts

LTE35 Jumbo wall mount will accommodate up to 35" monitors. TV rests on 26" deep platform with 1/2" front retainer lip. Top clamps have adhesive pads that wrap around the top edges of the TV to provide added stability. Maximum forward tilt 20° and 240° swivel capability. Load capacity 250 lbs. Wt. 79 lbs.

LTE1PA Platform wall mount with dual pivoting arm will accommodate most 19" and 20" TV receivers. TV rests on 20" wide by 13 1/2" deep platform with 1/2" front retainer lip. Maximum forward tilt 15° and 240° swivel capability. Load capacity 90 lbs. Wt. 20 lbs.

LTE1 Platform wall mount will accommodate most 19" and 20" TV receivers. TV rests on 20" wide by 13 1/2" deep platform with 1/2" front retainer lip. Maximum forward tilt 15° and 240° swivel capability. Load capacity 90 lbs. Wt. 18 lbs.

LTE2 Same as above but will accommodate most 25" to 27" TV receivers. TV rests on 26" wide by 13 1/2" deep platform. Load capacity 110 lbs. Wt. 24 lbs.

LTE4 Adjustable, full platform wall mount will accommodate most 19" to 27" TV receivers. TV rests on 13 1/2" deep platform with a full 1" front retainer lip which adjusts up to 30 1/2" wide. Platform is perforated to allow the monitor to be bolted down for added security. Maximum forward tilt 15° and 240° swivel capability. Load capacity 110 lbs. Wt. 19 lbs.

LTE6 Adjustable yoke-style ceiling mount will accommodate most 19" to 27" TV receivers. Adjusts from 21 1/2" to 33" without LTEV accessory VCR shelf, or 23 1/2" to 33" with LTEV. Includes 3"W x 10"L steel supports covered in non-skid material. Maximum forward tilt 15° and 240° swivel capability. Load capacity 110 lbs. Distance between ceiling and top of mount has four settings: 18 3/4", 22 1/2", 26 5/8" and 30 3/4". Wt. 35 lbs.

- Heavy gauge steel tube/plate assembly.
- Arc welded joints for maximum strength.
- Durable baked-on powder

coat paint finish.

- Safety strap included with Economount TV mounts.
- Mounting systems accommodate

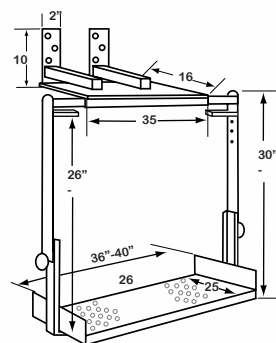

LTE35 • 36" - 40"W x 25"D x 30" - 40"H • 79 Lbs.

\$392

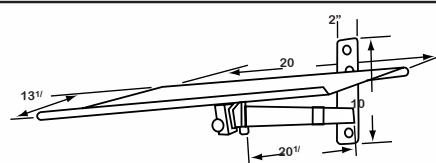

LTE1PA • 20"W x 13 1/2"D x 10"H • 20 Lbs.

\$209

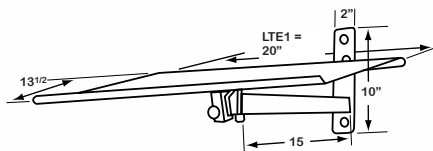

LTE1 • 20"W x 13 1/2"D x 10"H • 18 Lbs.

\$183

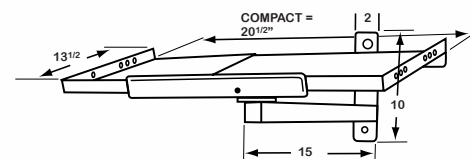

LTE4 • 20 1/2" - 30 1/2"W x 13 1/2"D x 10"H • 19 Lbs.

\$219

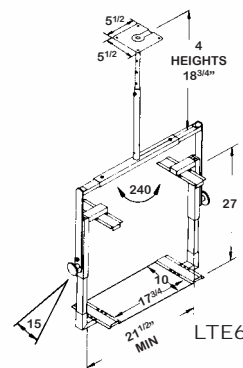

LTE6 • 21 1/2" - 33"W x 10"D x 27"H • 36 Lbs.

\$275

Mounting Systems

Economount TV/VCR Mounts

up to 35" monitors.

covers.

- Installations vary; therefore, mounting hardware is not included.
- Mounts include attractive plate

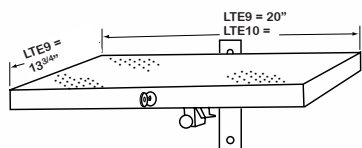

LTE10 • 26"W x 15"D • 30 Lbs. \$258

LTE9 • 20"W x 13 3/4"D • 24 Lbs. \$240

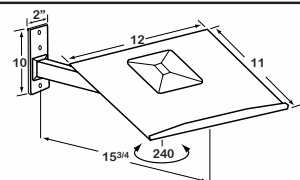

LTE11 • 12"W x 11"D x 10"H • 7 Lbs. \$101

LTE9 - Same as above but will accommodate most 19" and 20" TV receivers. TV rests on a 13 3/4" deep platform. Load capacity 90 lbs. Wt. 24 lbs.

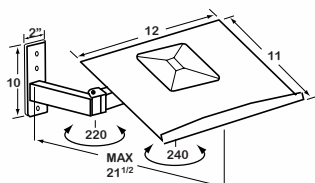

LTE12 • 12"W x 11"H • 7 Lbs. \$101

LTE11 - Platform wall mount will accommodate up to a 14" TV receiver. TV rests on a 12" wide by 11" deep platform with 1/2" front retainer lip. Maximum forward tilt of 15° and 240° swivel capability. Load capacity 66 lbs. Wt. 7 lbs.

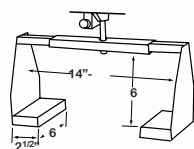

LTEV2 • 14"-21 1/2"W x 6"D x 6"H • 6 Lbs. \$132

LTE12 - Platform wall mount with pivoting arm will accommodate up to a 14" TV receiver. TV rests on a 12" wide by 11" deep platform with 1/2" front retainer lip. Maximum forward tilt of 15° and 240° swivel capability. Load capacity 66 lbs. Wt. 7 lbs.

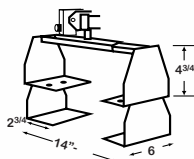

LTEVD • 14"-20"W x 6"D x 9 1/2"H • 7 Lbs. \$123

LTEV2 - Locking VCR bracket fits all Luxor LTE TV mounts. Adjusts from 14" to 21 1/2" wide to accommodate most DVD/VCR while resting on 2 1/2" x 6" brackets. Swivels independently of TV mount. All mounting hardware included. Wt. 6 lbs.

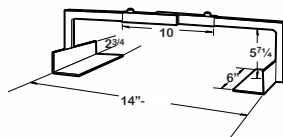

LTEV • 14"-20"W x 6"D x 5 1/2"H • 5 Lbs. \$90

LTEVD - Adjustable dual stacking VCR bracket fits all Luxor LTE TV mounts. Adjusts from 14" to 20" wide. VCRs rest on 2 3/4" x 6" brackets. Attaches and swivels independently of TV mount. All mounting hardware included. Wt. 7 lbs.

LTEV - VCR bracket fits all Luxor LTE TV mounts. Adjusts from 14" to 20" wide to accommodate most front loading recorders. VCR rests on 2 3/4" x 6" brackets. Swivels independently of TV mount. All mounting hardware included. Wt. 5 lbs.

ALL LUXOR PRODUCTS
QUICK-SHIP

Mounting Systems

TV Mounts & Mounting Options

LTE7 - Adjustable, full platform yoke style wall mount will accommodate most 19" to 29" TV receivers. TV rests on a 18" deep platform with full 1" front retainer lip that adjusts up to 30" wide. Platform is perforated to allow the monitor to be bolted down for added security. Maximum forward tilt 10° and 360° swivel capability. Load capacity 110 lbs. Wt. 35 lbs.

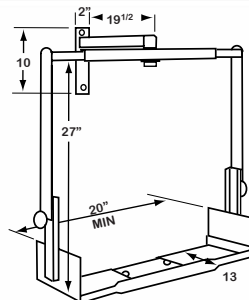

LTE7 • 20-30"W x 18"D x 27"H • 35 Lbs.

\$385

LTE8 - Adjustable full platform, yoke style, ceiling mount will accommodate most 19" to 29" TV receivers. TV rests on a 18" deep platform with full 1" front retainer lip that adjusts up to 30" wide. Platform is perforated to allow the monitor to be bolted down for added security. Maximum forward tilt 10° and 360° swivel capability. Load capacity 110 lbs. Wt. 34 lbs.

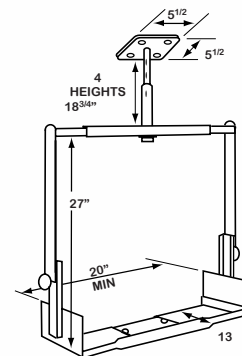

LTE8 • 20-30"W x 18"D x 27"H • 34 Lbs.

\$385

SP100 - Heavy duty steel, self-adhesive mounting plates. Plate attaches to your TV/VCR equipment, then bolt passes through the mount and is secured with nylon lock nut provided. Eliminates the need for screwing into your TV/VCR case. Two sets are recommended for TV installation. (Set of 2) Wt. 1 lb.



LTVS - Safety kit for TV mounts. Includes 2" heavy duty safety strap and two self-adhesive corners which attach to monitor case and serve as a track for safety strap. Wt. 2 lbs.

SP100 • Self-Adhesive mounting plate • 1 Lbs. \$14

LTVS • Safety Kit • 2 Lbs. \$52

LCD Monitor Mounts



Multi-Configurable!

Choose to mount using the double arm, single arm, or near flush configuration.



LLMSW • Holds Up To 21" LCD • 7 Lbs. \$112

LLMSW2537 • Holds Up To 37" LCD • 7 Lbs. \$157

Revolutionary Universal LCD Monitor Mounts offer the first multi-configurable design with the ability to configure the LLMSW into several different mounting styles. Can accommodate nearly every wall mount application, with just one mount! The LLMSW works with nearly every LCD monitor from 10" - 21" that uses a 75 or 100mm VESA standard.

LLMSW - Universal LCD monitor wall mount is a multi-configurable mount as a single arm, double arm articulating or near flush mount. Parts are provided. Holds most 10"-21" LCD monitors. Accommodates monitors with 75 or 100mm VESA standards. Adjustable tilt -5° to +10°. Mount rotates 240° at monitor, 160° at the wall, and 240° at the elbow joint (double arm configuration). Feed through wall plate with decorative cover. Load capacity 25 lbs. Wt. 7 lbs. Silver powder coat paint finish.

LLMSWB - Same as above with black finish.

LLMSW2537 - Same features as above, holds 25"-37" LCD monitors. 50 lb. capacity Wt. 7 lbs.

LLMSC - Universal LCD ceiling mount holds most 10"- 21" LCD monitors. Accommodates monitors with 75 or 100mm VESA standards. Adjustable tilt -5° to +30°. Mount rotates 360° at monitor. Mast telescopes 17"-27" from the ceiling. Includes clip based management system. Load capacity 25 lbs. Wt. 7 lbs. Silver powder coat paint finish.

LLMSC2537 - Same features as above, holds 25"-37" LCD monitors. Telescopes 18"-30" from ceiling. Wt. 7 lbs.

LLSW100 - Universal cantilever mount for LCD displays. Low profile design goes from a near flush 2 1/4" to 16" from wall. Easily adjusts to provide optimum viewing angles. 75x75/100x100 VESA compliant. Ideal for displays from 13" to 24" weighing up to 25 lbs. Includes complete mounting hardware kit. Constructed of die-cast aluminum.

LLMSD - Universal LCD monitor table/desk mount can be attached to any type of work surface as a clamp-on or bolt through mount. Holds most 10" - 21" LCD monitors. Accommodates monitors with 75 or 100mm VESA standards. Adjustable tilt -5° to +30°. Mount rotates 360°. Force arm has adjustable 0° to 60° forward tilt. Load capacity 25 lbs. Wt. 9 lbs. Silver powder coat paint finish.

Two sizes available for LLMSW and LLMSC!

Smaller size holds up to 21" monitor. Larger size holds up to 37" monitor.

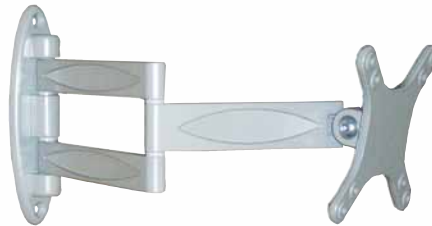

LLMSC • 17" - 27" From Ceiling • 7 Lbs. \$112

LLMSC2537 • 18" - 30" From Ceiling • 7 Lbs. \$157

LLSW100 • 16"D Extended - 2 1/4"D Folded \$56

Maximize your work space with the LLMSD!



LLMSD • Holds 10" - 21" LCD Monitors • 9 Lbs.

\$135

New Computer Workstations!

PSLP46 - 3-shelf desktop or laptop multi-media workstation with pull-out keyboard or laptop shelf. includes 4" casters, two with locking brake and 3-outlet electric assembly with 15' cord. Measures 24"W x 18"D x 46"H. \$477



Prestige

PS3945 - Mobile adjustable height computer workstation. Perfect for desktop or laptop computer. Height adjusts from 39" to 45". Features dark gray wood laminate desk tops with black powder coat painted steel frame. Includes 3" casters, two with locking brake. 24"W x 31"D x 39" - 45"H. \$199

Laptop/Presentation

LT Units Feature:

- Integral safety push handle is molded into top shelf.
- 3-outlet, 15' surge suppressing electric, UL and CSA listed.
- "Cable track" cord management system keeps cords neatly secured and free of entanglements.
- 4" casters, two with locking brake.
- Lifetime warranty. Molded shelves and legs won't stain, scratch, dent or rust.
- Retaining lip and sure grip safety pads prevent equipment from sliding.

LT342S - Versatile sit down laptop/overhead or standard computer workstation. Unit includes an adjustable keyboard shelf, surge electric and 4" casters, two with locking brake. Black color only. Wt. 33 lbs.

LT34 - Same as LT342S with additional middle shelf. Black color only. Wt. 38 lbs.

LT45 - Versatile laptop or standard computer workstation for stand-up applications. Unit includes an adjustable keyboard shelf, surge electric and 4" casters, two with locking brake. Black color only. Wt. 40 lbs.

LT45C - Same as LT45 with locking steel cabinet. Black/Gray color. Wt. 62 lbs.

LT45CLL - Same as LT45C with the addition of a locking lid and tub top shelf. Wt. 64 lbs.

LT45LL - Same as the LT45 with the addition of a locking lid and tub top shelf. Wt. 45 lbs.

LAMC2936 - Hydraulic adjustable multimedia cart, adjusts from 29" to 36" in height. The base of the cart can be utilized as a printer platform/CPU platform, for your requirements. Constructed of heavy duty laminate with a steel frame. The work surface measures 24"W x 29"D and pull-out keyboard shelf measures 27"W x 12"D. Assembly required. Teak color. Wt. 40 lbs.

LAMC3037 - Same as above with gray laminate finish and an adjustable height from 30" - 37".

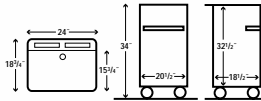

LT342S • 24"W x 18 1/2"D x 34"H • 33 Lbs. \$287

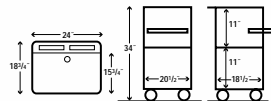

LT34 • 24"W x 18 1/2"D x 34"H • 38 Lbs. \$313

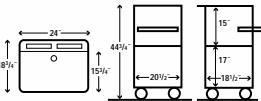

LT45 • 24"W x 18 1/2"D x 44 1/2"H • 40 Lbs. \$329

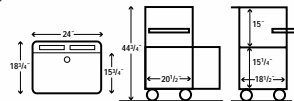

LT45C • 24"W x 18 1/2"D x 44 1/2"H • 62 Lbs. \$595

Includes Locking Lid!

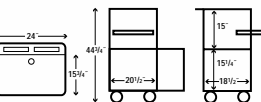

LT45CLL • 24"W x 18 1/2"D x 44 1/2"H • 64 Lbs. \$596

LT45LL • w/out cabinet • 45 Lbs. \$424

Shown with LLMSSD LCD mount (see page 15).

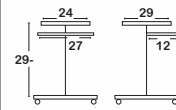

LAMC2936 • 27"W x 29"D x 29"-36"H • 40 Lbs. \$294

LAMC3037 • 27"W x 29"D x 30"-37"H • 40 Lbs. \$296

Computer Workstations

PC42KB - Stand-up or sit-down multi-media presentation center. Features dual keyboard shelves, CPU holder, 3-outlet surge suppressing electric assembly and integral safety push handle. Molded shelves and legs will not stain, scratch, dent or rust.

PC51KB - Stand-up multi-media presentation center. Perfect for laptop or CPU use. Features dual keyboard shelves, large bottom shelf for supplies or CPU, 3-outlet surge suppressing electric assembly and integral safety push handle. Molded shelves and legs will not stain, scratch, dent or rust.

PC44KBC - Stand-up multi-media presentation center. Features locking steel cabinet, middle shelf for supplies or storage, 3-outlet surge suppressing electric assembly and integral safety push handle. Molded shelves and legs will not stain, scratch, dent or rust.

LE42PC - Multi-media presentation workstation with four fixed shelves and two pull-out keyboard shelves that can adjust in height to any position on the legs. Includes molded cord wrap, built in handle, 3-outlet surge suppressing electric assembly and 4" casters, two with locking brake. Available in putty, black or gray.

LT45PC - Multi-media presentation cart with locking steel cabinet. Includes pull-out shelf and plenty of room for an overhead or LCD projector and laptop computer. Locking cabinet is perfect for storing your equipment when not in use. Includes 3-outlet surge suppressing electric assembly and 4" casters, two with locking brake.

LT34PC - Presentation cart with locking steel cabinet and pull-out shelf. Easy to transport and store with built in handle and removable side shelf. 3-outlet surge suppressing electric assembly mounts inside cabinet. Includes 4" casters two with locking brake.



PC42KB • 32"W x 24"D x 42"H • 54 Lbs. \$500

PC51KB • 32"W x 24"D x 51"H • 59 Lbs. \$505



PC44KBC • 32"W x 24"D x 51"H • 59 Lbs. \$755

LE42PC • 24"W x 18"D x 41½"H • 37 Lbs. \$659



LT45PC • 24"W x 32"D x 39½"H • 62 Lbs. \$567

LT34PC • 36½"W x 18"D x 41"H • 72 Lbs. \$647



AVJ42KBCDL • 29½"W x 18"D x 24-42"H • 77 Lbs. \$638



AVJ422KB4 • 24"W x 18"D x 24-42"H • 52 Lbs. \$499

AVJ42KBCDL - Compact steel computer workstation and presentation center with pull-out keyboard and mouse shelf. Features a drop leaf on each side to accommodate equipment and supplies as needed. Locking steel cabinet is perfect for storing supplies and equipment when not in use. Height of top shelf is adjustable from 24" - 42". Available in black only with cabinet. Available without cabinet in black, green, red, royal blue and yellow

AVJ422KB4 - Compact steel stand-up or sit-down multi-media presentation center with two pull-out keyboard and mouse shelves. Height of top shelf is adjustable from 24" - 42".

ATV56KB4 - Adjustable height multi-media workstation with pull out keyboard and mouse shelf. Keyboard can be mounted on the front or side of unit. Features roll formed shelves with cable pass through holes, 3-outlet surge suppressing electric assembly and 4" casters, two with locking brake.



ATV56KB4 • 28"W x 24"D x 36-54"H • 90 lbs.

\$598

LMC - Multi-media cart with locking cabinet and drawer. Features 15 5/8"W x 10 3/4" pull-out laptop shelf and 10"W x 12"D shelf that flips up from side. All metal construction. Comes with 3" casters, two with locking brake. Specify gray, black or brown/taupe. 19 1/4"W x 18 1/4"D x 35 1/4"H. Wt. 69 lbs.

LMC2 - Same as the LMC above with the addition of a second flip up side shelf and adjustable height inside shelf. 79 lbs.



LMC and LMC2 available in light gray, black & brown/taupe!

LMC • 19¼"W x 18¼"D x 35½"H • 69 Lbs. \$450

LMC2 • 19¼"W x 18¼"D x 35½"H • 79 Lbs. \$472

LMC2 Has adjustable height middle shelf inside.



Computer Workstations

Multi-Media Workstations

AVJ42KB - Compact steel mobile computer workstation with pull-out keyboard and mouse shelf. Unit is adjustable in 2" increments from 24"-42", and includes 3-outlet, 15' UL and CSA electric assembly, and 4" casters, two with locking brake. Wt. 50 lbs.

Specify color when ordering AVJ42KB.

AVJ42KB = Black

AVJ42KBGN = Green

AVJ42KBRD = Red

AVJ42KBYW = Yellow

AVJ42KBRB = Royal Blue

AVJCPU - Adjustable CPU holder for all AVJ42 carts attaches to either side of cart. Wt. 9 lbs.

AVJ42KBC - Same as the AVJ42KB with the addition of an all steel locking cabinet with full piano hinges. Wt. 62 lbs.

LSCW60 - Sleek and clean fully adjustable mobile LCD workstation. The workstation comes complete with a flat panel mounting bracket and 75mm and 100mm mounting plates, printer shelf, CPU holder, and a keyboard shelf with a mouse shelf. For your convenience, you can mount each of the accessories at any height on the 5' extruded aluminum mast. The unit comes complete with cord management and a stainless steel base with 2" furniture casters, two with locking brake. Accessory shelves are gray glossy powder coat finish. Load capacity 100 lbs. Wt. 65 lbs.

LSC50WMT - Wall mounted computer workstation with adjustable height shelves. Includes LCD monitor mounting bracket, printer shelf, CPU holder and keyboard shelf with mouse shelf. Any of the accessories can be mounted at any height on the 50" aluminum mast. Gray glossy powder coat finish.

LSC25WMT - Same as above with a length of 25", comes with one shelf only.

MSC37 - All steel welded multi-media cabinet with 4 roll-out shelves. Features locking front door, two large accessory trays inside door, and room for a LCD projector, DVD, VCR, laptop, disks, tapes and power adapter. Includes 5' security cable with padlock and two keys for attaching the cabinet to a fixed object, and 4" casters two with locking brake. Measures 21"W x 24"D x 37"H Wt. 105 lbs.



Set of folding drop leaf shelves (11"Wx18"D) available for any AVJ42KB! \$114

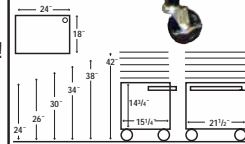
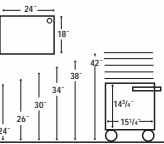

AVJ42KB • 24"W x 18"D x 24"-42"H • 50 Lbs. \$465

AVJ42KBC • 24"W x 18"D x 24"-42"H • 62 Lbs. \$587



Optional **LSCWE** six outlet electric assembly for LSCW60. Switch mounts on top of cord management system.

LSCW60 • 5' Tall • 2" Casters • 65 Lbs. \$1093

LSCWE • 6-outlet electric assembly • 3 Lbs. \$53



LSC50WMT • 50" long • 45 Lbs. \$753

LSC25WMT • 25" long • 11 Lbs. \$241



MSC37 • 21"W x 24"D x 37"H • 105 Lbs. \$874

Computer Workstations

Multi-Function Endura® Tables

Endura® Tables Feature:

- 48" Wide x 24" Deep shelves.
- Lifetime Warranty. Molded shelves and legs won't stain, scratch, dent or rust.
- 3-outlet, 15' surge suppressing electric assembly, UL and CSA listed except for models LEW40C and LEW29C.
- Available in putty, black or gray colors.
- Molded cord wrap attaches around table leg and swings out for easy access except for models LEW40C and LEW29C.
- Retaining lip around back and sides of shelves.
- Available in two or three shelf models.
- Models ship via UPS.
- All shelves reinforced with two aluminum bars.

LEW35 - Three shelf workstation Shelf Clearance 12^{1/2"}

LEW32 - Two shelf workstation Shelf Clearance 23^{1/2"}

LEW32TWR - Two shelf workstation with built-in tower support plates which can position and support your CPU on the right, left or middle of the bottom shelf.

LEW40C - 40" high, three shelf extra wide mobile workcenter with steel locking, vented cabinet. Ideal for use with multimedia equipment or heavy equipment, such as large screen monitors. Weight capacity 300 lbs. Specify putty, gray or black unit with black cabinet only. Pneumatic and semi-pneumatic tires available. Wt. 140 lbs.

LEW28 - Two shelf workstation Shelf Clearance 19"

LEW29C - 29" high, two shelf extra wide mobile work center with steel locking, vented cabinet. Ideal for use with heavy equipment such as laminating machines or large screen monitors. Weight capacity 300 lbs. Specify putty, gray, or black unit with black cabinet only. Pneumatic and semi-pneumatic tires available. Wt. 102 lbs.

LEW Options

LEMRO - Pull-out keyboard shelf for dual purpose. LEW units will accommodate up to 2 LEMRO keyboards. Order individually. Gray, black or putty color. Wt. 7 lbs. \$98

LEWKB - Pull-out keyboard shelf with pull-out mouse shelf, not to be used for dual, side by side keyboards. See LEMRO. Black color only. Wt. 3 lbs. \$89

TLMD - Slide out media storage drawer. 12^{1/4"}W x 16^{3/4"}L x 3"D. Black only. Wt. 4 lbs. \$60

TLMD2 - Slide out media storage drawer. 12^{1/4"}W x 16^{3/4"}L x 6"D. Black only. Wt. 6 lbs. \$72



Shown with optional P8 pneumatic tires, TLMD, TLMD2 drawers, and LEWKB keyboard shelf. See below for options.

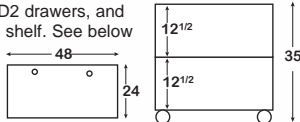

LEW35 • 48"W x 24"D x 35"H • 79 Lbs. \$592

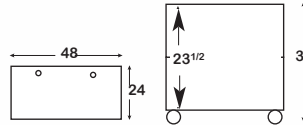

LEW32 • 48"W x 24"D x 32"H • 55 Lbs. \$455

LEW32TWR • 48"W x 24"D x 32"H • 60 Lbs. \$509

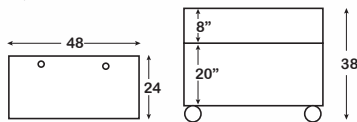

LEW40C • 48"W x 24"D x 38"H • 140 Lbs. \$983

LEW shelves reinforced with two aluminum bars!

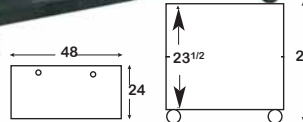
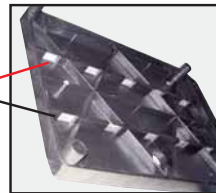

LEW28 • 48"W x 24"D x 28"H • 56 Lbs. \$450

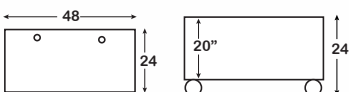

LEW29C • 48"W x 24"D x 24"H • 102 Lbs. \$876



Solid rubber high profile semi-pneumatic tires. Order separately.

SP8 • 8" • 27 Lbs. \$225



Heavy-duty 8" foam rubber casters. Add suffix FR to model number.

FR8 • 8" • 29 Lbs. \$169

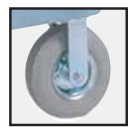

8" pneumatic tires, 2 fixed, 2 swivel with brake.

P8 • 8" • 29 Lbs. \$188

Computer Workstations

Children's Workstations

LEW26 - 26" high, two shelf extra wide computer workstation especially designed for early childhood applications, grades K-6. Complete with electric and 4" casters, two locking. Shelf clearance 17 1/2". Specify putty, black or gray color. Wt. 55 lbs.

LEM32DUO - Workstation with leg room cut-out with multi-height capabilities. Assemble to your choice 22" or 24". Complete with surge electric and 4" casters, two locking. LSS safety strap included. Ideal for K-6 age group. Specify putty, black or gray color. Wt. 35 lbs.

LEM32DUOK - Video or computer cart with multi-height capability. Has pull-out keyboard shelf and leg room cut-out. Complete with surge electric and 4" casters, two locking. LSS safety strap included. Assemble to your choice of 22" or 24" high. Specify putty, black or gray color. Wt. 41 lbs.

LEM332KB - Dual computer workstation with two pull-out keyboards, wide workspace for two monitors, and wide lower shelf for two CPU towers. Mouse shelf attaches left or right side. Cable pass through hole for easy cord management. Complete with ESE 6-outlet 15' surge suppressing electric assembly and 4" casters, two locking. Specify putty, black or gray color. Wt. 57 lbs.

LEM332KBC - Dual computer workstation with bottom cabinet. and 2" casters. Specify putty, black or gray color. Wt. 104 lbs.

LEW Options

LEMRO - Pull-out keyboard shelf for dual purpose. LEW units will accommodate up to 2 LEMRO keyboards. Order individually. Gray, black or putty color. Wt. 7 lbs. \$98

LEWKB - Pull-out keyboard shelf with pull-out mouse shelf, not to be used for dual, side by side keyboards. See LEMRO. Black color only. Wt. 3 lbs. \$89

TLMD - Slide out media storage drawer. 12 1/4"W x 16 3/4"L x 3"D. Black only. Wt. 4 lbs. \$60

TLMD2 - Slide out media storage drawer. 12 1/4"W x 16 3/4"L x 6"D. Black only. Wt. 6 lbs. \$72



Shown with 2 optional LEMRO keyboard shelves.

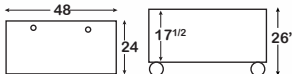

LEW26 • 48"W x 24"D x 26"H • 55 Lbs. \$447

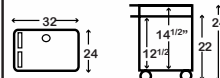

LEM32DUO • 32"W x 24"D x 22, 24"H • 35 Lbs. \$435

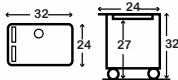

LEM332DUOK • 32"W x 24"D x 32"H • 41 Lbs. \$557

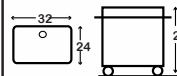

LEM332KB • 32"W x 24"D x 29"H • 57 Lbs. \$490

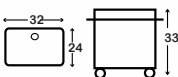

LEM332KBC • 32"W x 24"D x 33"H • 104 Lbs. \$803



ESE • Optional 6-outlet electric • 4 Lbs. \$83

Computer Workstations

Endura® Computer Workstations

- Integral safety push handle is molded into top shelf.
- 3-outlet, 15' surge suppressing electric, UL and CSA listed.
- "Cable track" cord management system keeps cords neatly secured and free of entanglements.
- Assembly required.
- Lifetime warranty. Molded shelves and legs won't stain, scratch, dent or rust.
- Retaining lip and sure grip safety pads prevent equipment from sliding.

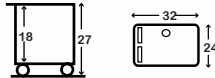

LEM32 • 32"W x 24"D x 27"H • 35 Lbs.

\$425

LEM32 - Workstation with leg room cut-out and 4" casters, two with locking brake. Specify putty, black or gray color. Assembly required. Wt. 35 lbs.

LEM32T - Workstation with leg room cut-out, monitor platform, and 4" casters, two with locking brake. Specify putty, black or gray color. Assembly required. Wt. 42 lbs.

LEM32K - Interactive video cart with pull-out keyboard shelf. Complete with surge electric and 4" casters, two with locking brake. Specify putty, black or gray color. Assembly required. Wt. 41 lbs.

OEPS32 - 31" three shelf printer stand with chrome wire print-out basket and 2" casters, two with locking brake. Assembly required. Specify putty, gray, or black color. Wt. 24 lbs.

OEPS26 - Same as above with two shelves and 23" high. Wt. 19 lbs.

EMS - Mounts to existing pull-out keyboard shelf on workstations. Wt. 8 lbs.

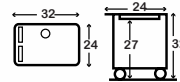

LEM32T • 32"W x 24"D x 27"H • 42 Lbs.

\$532

LEM32K • 32"W x 24"D x 32"H • 41 Lbs.

\$589

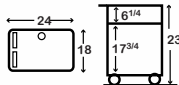
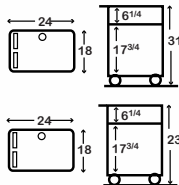

OEPS32 • 24"W x 18"D x 31"H • 24 Lbs. \$284

OEPS26 • 24"W x 18"D x 23"H • 19 Lbs. \$231

EMS • Slide out mouse shelf • 8 Lbs.

\$64



Computer Workstations

Endura® Computer Workstations

LEM32TWR - Workstation designed for CPU tower users. Lower shelf includes 9 1/2"W x 20"D side area with built-in tower support plates for safety. Complete with surge electric and five 2" casters, two with locking brake. Putty, black or gray color. Wt. 36 lbs.

LEM32TWRK - Same as LEM32TWR with pull-out keyboard shelf (19 1/2"Wx16"D). Putty, black or gray color. Wt. 47 lbs.

LEM32TWRT - Same as LEM32TWR with monitor platform. Putty, black or gray color. Wt. 42 lbs.

LEM32TWRTK - Workstation designed for CPU tower users with monitor platform and pull-out keyboard shelf. Lower shelf includes 9 1/2"W x 20"D side area with built-in tower support plates for safety. Complete with surge electric and five 2" casters, two with locking brake. Specify putty, black or gray color. (19 1/2"W x 16"D). Wt. 55 lbs.

LEM32TWRKPS -Interactive video/computer cart with full top shelf and pull-out keyboard shelf and LEPS3 printer stand. Complete with surge electric and 2" casters, two with locking brake. Specify putty, black or gray color. Assembly required. Wt. 56 lbs.

LEM32S - Workstation with LEPS3 printer stand. Complete with surge electric and 2" casters. Specify putty, black or gray color. Assembly required. Wt. 49 lbs.

LEPS3 - 15 1/2" high, 2 shelf printer stand with 4" casters can also be ordered separately. Specify putty, black or gray color. Wt. 15 lbs.

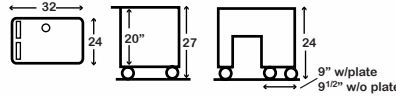

LEM32TWR • 32"W x 24"D x 24"H • 36 Lbs. \$499

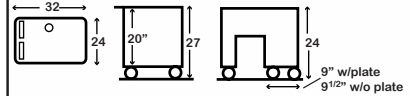

LEM32TWRK • 32"W x 24"D x 27"H • 47 Lbs. \$570



LEM32TWRT • 32"W x 24"D x 27"H • 42 Lbs. \$584



LEM32TWRTK • 32"W x 24"D x 27"H • 55 Lbs. \$660

Both units include LEPS3 printer stand. Can be ordered separately. \$168

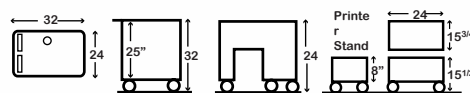

LEM32TWRKPS • 32"W x 24"D x 32"H • 56 Lbs. \$623



LEM32S • 32"W x 24"D x 32"H • 49 Lbs. \$614

Computer Workstations

Endura® Computer Workstations

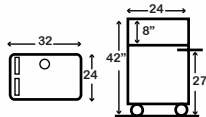

LEM32FT • 32"W x 24"D x 42"H • 57 Lbs. \$674

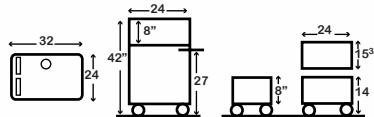

LEM32FTO • 32"W x 24"D x 29 1/4"H • 73 Lbs. \$840

LEM32FT - Interactive video cart with full top shelf and pull-out keyboard shelf. Complete with surge electric and 4" casters, two with locking brake. Specify putty, black or gray color. Assembly required. Wt. 57 lbs.

LEM32FTO - Same as LEM32FT with overhead projector stand and 2" casters. Specify putty, black or gray color. Assembly required. Wt. 73 lbs.

LEM32P - Heavy duty sit-down mobile workstation with pull-out keyboard shelf. Complete with surge electric and 8" pneumatic tires. Specify putty, black or gray color. Assembly required. Wt. 70 lbs.

LEM32P5 - Same as above except 28"H with solid core 5" plate casters in lieu of pneumatic tires. Wt. 53 lbs.

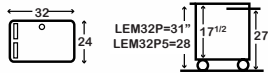

LEM32P • 32"W x 24"D x 31"H • 70 Lbs. \$913

Above unit with 5" plate casters in lieu of pneumatic tires.

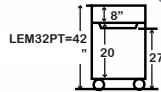

LEM32PT • 32"W x 24"D x 42"H • 85 Lbs. \$1031

LEM32PT - Heavy duty stand-up workstation with pull-out keyboard shelf and full top shelf. Complete with surge electric and 8" pneumatic tires. Specify putty, black or gray color. Assembly required. Wt. 85 lbs.

LEM32PT5 - Same as above except 39"H with solid core 5" plate casters in lieu of pneumatic tires. Wt. 67 lbs.

Above unit with 5" plate casters in lieu of pneumatic tires.



LEM32P5 • 32"W x 24"D x 28"H • 53 Lbs. \$829

LEM32PT5 • 32"W x 24"D x 39"H • 67 Lbs. \$945



Computer Workstations

Endura® Computer Workstations

LEMS - Workstation with leg room cut-out. Complete with surge electric and 4" casters, two with locking brake. Putty, black or gray color. Wt. 20 lbs.

LEMST - Same as LEMS with monitor platform. Wt. 28 lbs.

LEMSDUO - Same as LEMS with multi-height. Assemble to your choice 22" or 24". Includes LSS safety strap. Ideal for K-6 age group. Wt. 21 lbs.

LEMFP - Workstation with one adjustable pull-out keyboard shelf (19 1/2"W x 16"D) and fixed printer shelf. Versatile child/adult application. Complete with surge electric and 4" casters, two with locking brake. Specify putty, black or gray color. Wt. 36 lbs.

LEMPS - Workstation with two adjustable pull-out shelves (19 1/2"W x 16"D). Complete with surge electric and 4" casters, two with locking brake. Specify putty, black or gray color. Wt. 37 lbs.

LEMSS - Workstation with one adjustable pull-out shelf (19 1/2"W x 16"D). Complete with surge electric and 4" casters, two with locking brake. Specify putty, black or gray color. Wt. 30 lbs.

LEM58 - Stand-up workstation with one adjustable pull-out shelf (19 1/2"W x 16"D). Complete with chrome wire print-out basket, surge electric and 2" casters, two with locking brake. Specify putty, black or gray color. Wt. 43 lbs.

LE58 - Same as the LEM58 with 16" clearance between middle shelves. Shown with optional 4" casters. Specify putty, black or gray color. Wt. 43 lbs.

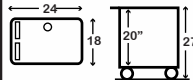

LEMS • 24"W x 18"D x 27"H • 20 Lbs. \$299

LEMST • Same as above w/monitor platform • 28 Lbs. \$355

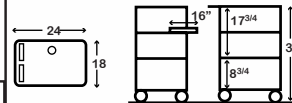

LEMFP • 24"W x 18"D x 35"H • 36 Lbs. \$439



LEMPS • 24"W x 18"D x 33"H • 37 Lbs. \$547

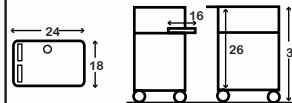

LEMSS • 24"W x 18"D x 33"H • 30 Lbs. \$408

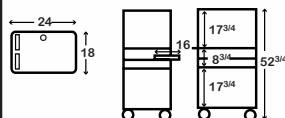

LEM58 • 24"W x 18"D x 52 3/4"H • 43 Lbs. \$516

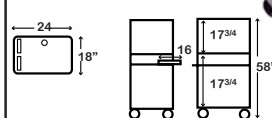

LE58 • 24"W x 18"D x 58"H • 43 Lbs. \$519

Shown with optional 4" casters.



Computer Workstations

Economical Hi-Tech



LCTL2428 • 28"W x 29"D x 28"H • 36 Lbs. \$164



LCTL1830 • 18"W x 21"D x 30"H • 29 Lbs. \$112



LCTL2435 • 24"W x 29"D x 35"H • 37 Lbs. \$168



LCTL2452 • 24"W x 29"D x 52"H • 46 Lbs. \$232

LCTL2428 - 28"W x 29"D x 28"H 2 shelf workstation design with adjustable height of shelves up to 28" max. Shelves can be interchanged for application. Black frame color. Includes 2" casters two with locking brake. Moderate assembly required. Wt. 36 lbs.

LCTL1830 - 18"W x 21"D x 30"H Workstation with adjustable height shelves. Sturdy construction provides versatility in compact locations. Black frame color. Includes 2" casters two with locking brake. Moderate assembly required. Wt. 29 lbs.

LCTL2435 - 24"W x 29"D x 35"H 2 shelf workstation with adjustable height of shelves up to 35" height max. Shelves can be interchanged for application. Black frame color. Includes 2" casters two with locking brake. Moderate assembly required. Wt. 37 lbs.

LCTL29 - 24"W x 29"D x 28"H Single shelf workstation. This sturdy black tubular frame unit has 2" casters, two with locking brake. Moderate assembly required. Wt. 31 lbs.

LCTL2452 - 24"W x 29"D x 52"H 2 shelf workstation. The sturdy black tubular frame unit has 2" casters, two with locking brake. Moderate assembly required. Wt. 46 lbs.

All LCTLs
While
Supplies
Last!



LCTL29 • 24"W x 29"D x 28"H • 31 Lbs. \$136

Computer Workstations

Adjustable Height Workstations

LHDAWS - Two shelf adjustable height computer workstation. Shelves adjust independently in a fluid motion using crank. They adjust from 19¼" to 29½" in height. Perfect for use in an environment used by children and adults where frequent height adjustment is necessary. Black metal frame with teak wood colored top. 43"W x 29½"D x 19¼"-29½"H. Wt. 81 lbs.

LACT2030 - Hydraulic adjustable height computer workstation. Adjusts in height from 20½"-30½". Features wood laminate top and keyboard shelf with metal frame. 47"W x 27½"D x 20½"-30½"H. Wt. 63 lbs.

LCW2948 - Fully adjustable, mobile computer workstation with laminate shelving surrounded by steel frame. Five, fun, steel frame colors all selected to match a popular line of computers. Complete with 2" furniture casters, two with locking brake. Light gray color available for shelving only. Specify gray, blue, rose, orange or purple frame. Assembly required. Wt. 53 lbs.

While Supplies Last!



Both shelves adjust to any height between 19¼" - 29½" using crank!

LHDAWS • 43"W x 29½"D x 19¼"-29½"H • 81 Lbs.

\$450

While Supplies Last!



LACT2030 • 47"W x 27½"D x 20½"-30½"H • 63 Lbs.

\$298

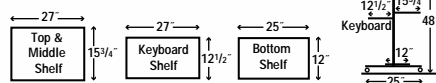

LCW2948 • 27"W x 25"D x 48"H • 53 Lbs.

\$318

Computer Workstations

Modern Computer Workstations



LCT26 • 47 $\frac{1}{4}$ "W x 24"D x 32"H • 53 Lbs. \$284



LCT6 • 29 $\frac{1}{4}$ "W x 19 $\frac{1}{2}$ "D x 31 $\frac{1}{4}$ "H • 41 Lbs. \$264



LCT6B • 29 $\frac{1}{4}$ "W x 19 $\frac{1}{2}$ "D x 31 $\frac{1}{4}$ "H • 53 Lbs. \$302



LCT2 • 29"W x 18 $\frac{3}{4}$ "D x 31"H • 45 Lbs. \$281



LCT5A • 23"W x 19 $\frac{1}{4}$ "D x 33"H • 41 Lbs. \$264

LCT26 - Extra wide wood and steel computer workstation. Generous work surface to accommodate a variety of hardware and equipment. Complete with pull-out keyboard shelf that opens up to a supply drawer, 2" casters, two with locking brake. Keyboard shelf measures 28 $\frac{1}{4}$ "W x 11 $\frac{3}{4}$ "D. Oak/Black frame. Wt. 53 lbs.

LCT6 - All steel, wood look top computer workstation complete with pull-out keyboard shelf, and 2" casters, two with locking brake. Keyboard shelf measures 12" x 28". Teak/Black frame. Wt. 41 lbs.

LCT6B - Wood and steel computer workstation with pull-out keyboard shelf, telephone shelf, copy holder, and 2" casters, two with locking brake. Keyboard shelf measures 12" x 28". Oak/Gray color. Wt. 53 lbs.

LCT2 - All steel computer workstation complete with pull-out keyboard shelf, built-in CD rack, printer stand and 2" casters, two with locking brake. Keyboard shelf measures 12" x 28". Gray color. Wt. 45 lbs.

LCT5A - All steel adjustable computer workstation with two pull-out shelves, CPU holder and 2" casters, two with locking brake. Height adjusts from 29" to 33" in 1" increments. Pull-out shelves measure 15 $\frac{1}{4}$ " x 22 $\frac{1}{4}$ ". Gray color. Wt. 41 lbs.

LCT Options

SPEAKER BRACKETS

LCTSB - All steel adjustable speaker brackets for LCT2 model only. Gray color. Wt. 3 lbs. \$37

CPU PLATFORM

LCPU1A- All steel adjustable CPU platform for LCT2 model only. Gray color. Wt. 3 lbs. \$72

COPY HOLDER

LCTCH - Copy holder to hold and secure your documents for LCT2 model only. Gray color. Wt. 4 lbs. \$28

ELECTRIC ASSEMBLY

LCTE - 15' surge suppressing electric assembly includes mounting hardware. Wt. 2 lbs. \$84



LCT2 features CD/DVD storage rack and printer stand.

Computer Workstations

Modern Style Workstations

LCT43 - Extra wide computer workstation w/ extra wide pull-out keyboard shelf and mobile combination printer/CPU stand. Constructed of heavy duty laminate with steel frame. Comes with 3-outlet, 15' surge suppressing electric assembly. Has 3" casters, two locking on workstations, and 2" casters, two locking on printer/CPU stand. Assembly required. Measures 27^{1/2}"H x 29"D x 34^{1/2}"W. Teak color with black frame. Wt. 67 lbs.

PCS24 - Adjustable height personal computer workstation complete with keyboard shelf, hinged mouse shelf (which mounts on left or right side), bottom storage or printer shelf, CPU tower holder (which mounts on right or left side) 3-outlet, 15' surge suppressing electric assembly, and 2" casters, two with locking brake. Constructed of heavy duty laminate with steel frame. Assembly required. Teak color with black frame. Wt. 44 lbs.

LCT15 - Wood and steel 3-tier computer workstation with semi-recessed monitor well, pull-out keyboard shelf, CPU tower holder, printer shelf, CD storage, and 2" casters, two with locking brake. Assembly required. Teak color with black frame. Wt. 70 lbs.

UCC1 - Personal computer workstation with pull-out keyboard and mouse shelf. Features all wood construction, 3" casters, two with locking brake, LCD monitor shelf and locking cabinet. 22^{3/4}"W x 19^{3/4}"D x 37^{1/4}"H. Wt. 73 lbs.

While Supplies Last!

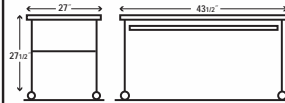

LCT43 • 34^{1/2}"W x 29"D x 27^{1/2}"H • 67 Lbs.

\$179

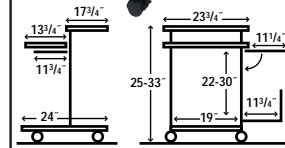
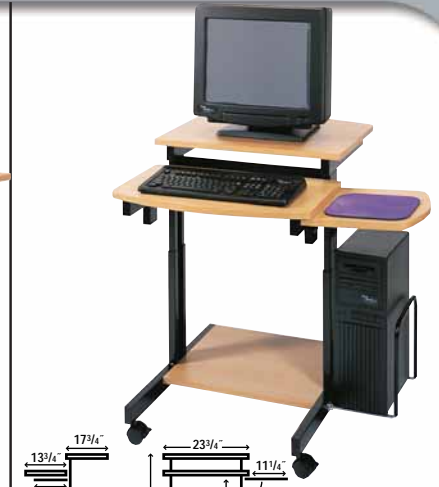

PCS24 • 23^{3/4}"W x 24"D x 25-33"H • 44 Lbs.

\$265

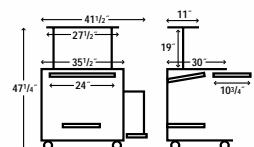

LCT15 • 41^{1/2}"W x 30"D x 47^{1/4}"H • 70 Lbs.

\$229

While Supplies Last!



UCC1 • 22^{3/4}"W x 19"D x 37^{1/4}"H • 73 Lbs.

\$249

Computer Workstations

Versatile Computer Workstations

LCW180 - Two person/tower computer workstation complete with keyboard shelves, and CPU tower holder. Has a wide work surface for supplies and equipment. Constructed of heavy duty laminate with steel frame. Comes with two 3-outlet, 15' surge suppressing electric assemblies. Assembly required. Teak color with light gray frame. Wt. 105 lbs.

LCW180B - Same as above, with black base color instead of gray.

LCW120D - Single person/tower computer workstation complete with keyboard shelf, and CPU tower holder. Has a wide work surface for supplies and equipment. Constructed of heavy duty laminate with steel frame. Comes with 3-outlet, 15' surge suppressing electric assembly. Assembly required. Teak color with light gray frame. Wt. 57 lbs.

LCW120DB - Same as above, with black base color instead of gray.

LCW120 - Same as the LCW120 without the locking front and rear cabinet and no electric assembly. Limited Time Offer. \$273

LCW180 & LCW120 both have hidden cable pass through in the leg.



Includes Locking Front & Rear Access Doors!

Also available with black base.

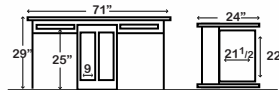

LCW180 • 71"W x 24"D x 29"H • 105 Lbs.

\$655



Includes Locking Front & Rear Access Doors!

Also available with black base.

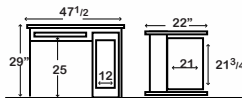

LCW120D • 47 1/2"W x 22"D x 29"H • 57 Lbs.

\$441



Yellow

Red

Blue

Purple

Gray

Charcoal

LCT29 - Computer workstation made with wood and steel. Six, fun colors to choose from to energize your environment with color. Complete with 2" furniture casters, two with locking brake. Comes with pull-out keyboard shelf, and a pull-out mouse shelf. Specify yellow, red, blue, purple, gray, or charcoal. Assembly required. Wt. 36 lbs.

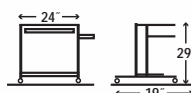

LCT29 • 24"W x 19"D x 29"H • 36 Lbs.

\$203



Computer Workstations

Computer Security Centers

CSC61 - Locking steel, heavy duty mobile computer security center with a plexiglass window and welded keyboard shelf. Includes 3-outlet, 15' surge electric assembly U.L. and C.S.A. listed, ventilation louvers in back panel and heavy-duty, 4" ball-bearing casters, 2 with locking brake. Cabinet ships assembled. Wt. 125 lbs.

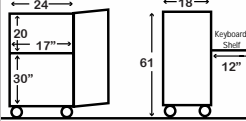

CSC61 • 24"W x 18"D x 61"H • 125 Lbs. \$1142

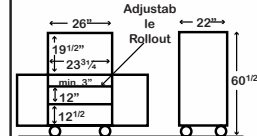

CSC58KD • 26"W x 22"D x 60 1/2"H • 118 Lbs. \$622

CSC57 - Locking mobile computer security center. Includes roll-out keyboard shelf and 3-outlet, 15' surge electric assembly U.L. and C.S.A. listed, ventilated upper back panel with easy cabling access and heavy-duty, 3" ball-bearing casters, two with locking brake. Model comes complete with 2 attractive locking tambour doors. Unit supports up to a 19" monitor. Assembly required. Gray color only. Wt. 125 lbs.

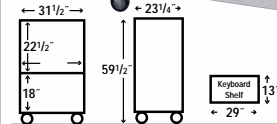

CSC57 • 31 1/2"W x 23 1/4"D x 59 1/2"H • 125 Lbs. \$846

CSC47 - Same as CSC57 without lower locking tambour door. Assembly required. Wt. 125 lbs.

PS570KD - Steel video security center with locking doors. Includes one fixed monitor shelf and one adjustable stationary equipment shelf. Lower cabinet allows for tape and equipment storage. Complete with 3-outlet, 15' surge suppressing power cord, UL and CSA listed. Ships knocked down. Wt. 118 lbs.

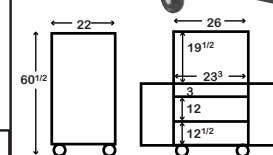

PS570KD • 26"W x 22"D x 60 1/2"H • 118 Lbs. \$534

LLTS24 - All steel laptop computer workstation with 24 compartments for storing laptops. Has wide, nonskid top surface for supplies and equipment. Surge suppressing electric assembly is optional. Putty color. Wt. 225 lbs.

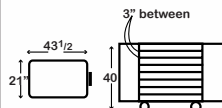

LLTS24 • 43 1/2"W x 21"D x 40"H • 225 Lbs. \$1747



LLTS24 four 6-outlet electric assemblies for LLTS24.

LLTSE - Four 6-outlet surge suppressing electric for LLTS24 models. Wt. 16 lbs.

LLTSE • Four, 6-outlet electric • 16 Lbs. \$329

Computer Workstations

Multi-Media Workstations

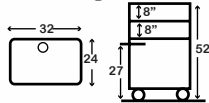

LE554 • 32"W x 24"D x 52"H • 81 Lbs. \$697

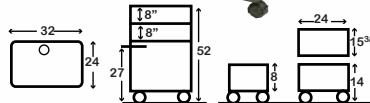

LE554TO • 32"W x 24"D x 52"H • 97 Lbs. \$859

LE554 - Interactive video cart with pull-out keyboard shelf that can be positioned on either the side or front of cart. Complete with surge electric and 4" casters two with locking brake. Black color. Assembly required. Wt. 81 lbs.

LE554TO - Interactive video cart with overhead stand and pull-out keyboard shelf. Keyboard shelf can be positioned on either the side or front of cart. Complete with surge electric and 2" casters. Black color. Assembly required. Wt. 97 lbs.

MWC54 - Pyramid shape, three shelf, large screen multi-media cart with 5" casters, two with locking brake, 3-outlet 15' UL & CSA listed electric assembly, 2" wide 20' long safety strap with easy lock buckle. Cart includes 23¹/₂" x 28¹/₂" locking turntable with 150 degree swivel for best monitor viewing position, 18¹/₂" x 17" accessory shelf which mounts under top shelf, built-in CPU tower support plates, and pull-out mouse shelf. Constructed of 7/8" high-density particleboard with resilient vinyl T-moulding. Assembly required. Wt. 177 lbs.

While Supplies Last!

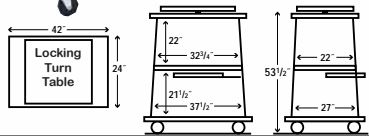

MWC54 • 42"W x 24"D x 53¹/₂"H • 177 Lbs. \$855

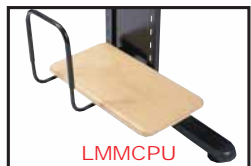
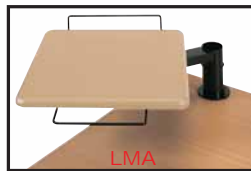

LMMW48 - Multimedia computer workstation complete with adjustable overhead projector platform. Work surface provides ample room for all your computer and overhead needs. Unit features 3-outlet, 15' surge electric assembly, UL and CSA listed with adjustable leveler glides. Overhead projector platform adjusts easily with a hydraulic pneumatic lever and can be adjusted above, below, or flush with work surface top. Constructed of a heavy-duty laminate and steel frame. Assembly required. Teak color/black frame. Wt. 62 lbs. Please note: LMMW48 unit shown with optional LMMCPU holder and LMA monitor platform, both sold separately.

LMA - Monitor platform easily swivels and has side-to-side movement for better viewing and increased work surface space. Weight capacity 30 lbs. 16"W x 16"D. Assembly required. Wt. 12 lbs.

LMMCPU - Adjustable CPU tower holder. Teak color with black frame. 9"W x 18"D. Assembly required. Wt. 7 lbs.

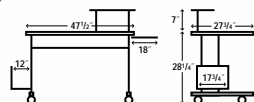

LMMW48 • 47¹/₂"W x 27¹/₂"D x 28¹/₄"H • 62 Lbs. \$325

LMA • 16"W x 16"D • 12 Lbs. \$150

LMMCPU • 9"W x 18"D • 7 Lbs. \$31

Computer Workstations

Steel Computer Workstations

AVJOH48MM2 - 2 shelf steel adjustable height multi-media center has pull-out keyboard shelf with built-in mouse shelf. Work surface adjusts from 31" to 51". Transparency drawer located under projector well. Includes 8" pneumatic tires. Wt. 104 lbs.

AVJOH48M25 - Same as above with solid core 5" plate casters. Work surface adjusts from 28^{1/4"} to 48". Wt. 90 lbs.

AVJOH48MM - 3 shelf steel adjustable height multi-media center has pull-out keyboard shelf with built-in mouse shelf. Work surface adjusts from 31" to 51". Transparency drawer located under projector well. Middle shelf adjusts to allow for a variety of equipment, including a CPU tower. Includes 8" pneumatic tires. Wt. 131 lbs.

AVJOH48M5 - Same as above with solid core 5" plate casters. Work surface adjusts from 28^{1/4"} to 48". Wt. 107 lbs.

MMC56 - All steel 3 shelf steel multi-media center with a powder coat paint finish. Center comes complete with a keyboard shelf with pull-out mouse shelf (R or L), a slide shelf with 8" clearance for scanner/printer, adjustable CPU bracket, adjustable VCR/DVD mount, 6-outlet surge suppressing electrical assembly, LRS safety strap, 4" ball bearing casters, two with locking brake. Clearance between the bottom and middle shelf is 22" and between the middle and top shelf is 24". The center measures 42" W x 24"D x 56"H. Assembly required. Black color. Wt. 110 lbs.

CS36 - All steel computer workstation with fully adjustable pull-out keyboard shelf. Adjusts from 23" to 34" in height. Has bottom shelf with CPU tower holder. Comes with 4" casters, two with locking brake. Black color. Wt. 53 lbs.

CS36S - Same as above with 3-outlet surge protected electric. Black color. Wt. 54 lbs.

LFT71 - Wide workcenter can be used for multiple applications. Table folds down to for easy, space-saving storage. Constructed of heavy duty laminate with steel frame. Assembly required. Teak color with light gray frame. Wt. 55 lbs.



Shown with optional SP8 semi-pneumatic tires.

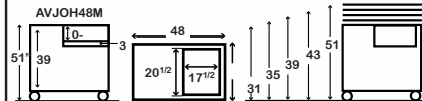

AVJOH48M25 • Same w/5" plate casters • 90 Lbs. \$831

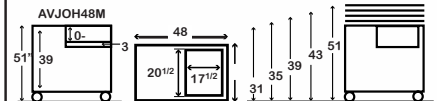

AVJOH48MM • 48"W x 24"D x 31-51"H • 131 Lbs. \$966

AVJOH48MM2 • 48"W x 24"D x 31-51"H • 104 Lbs. \$912

AVJOH48M5 • Same w/5" plate casters • 107 Lbs. \$886

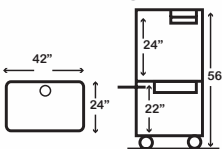

MMC56 • 42"W x 24"D x 56"H • 110 Lbs. \$511

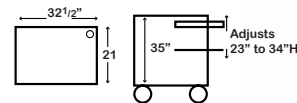

CS36 • 32^{1/2}"W x 21"D x 23-34"H • 53 Lbs. \$356

CS36S • With electric • 54 Lbs. \$409

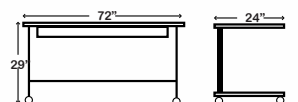

LFT71 • 72"W x 24"D x 29"H • 55 Lbs.

\$350

Steel Computer Workstations



EMCA48T - All steel adjustable height workstation with terminal platform that adjusts and tilts in 1" increments. Terminal platform can be installed on left or right side of workstation. Work surface adjusts from 26" to 40" in 2" increments. Putty color. Wt. 78 lbs.

EMCA48 - Same as above without terminal platform. Putty color. Wt. 72 lbs.

LX9128 - Adjustable height laptop table complete with 2" casters, 2 with brake. Plastic knob on adjusting mechanism allows for height adjustments. Top with retainer lip tilts to allow for flat work surface. Constructed of heavy-duty laminate with steel frame. Minimal assembly required. Red Oak with black frame. Wt. 23 lbs.

EMCA48T • 48"W x 24"D x 26-40"H • 78 Lbs. \$699 **EMCA48** • w/out terminal platform • 72 Lbs. \$642



LX9128 • 23 1/2"W x 19"D x 36 1/2-45"H • 23 Lbs. \$186



New Hi-Tech!



Desk top available in:



Bright Blue



Gray

LCD20 - Childrens desk with wood top. Top is available in bright blue and gray. Features tray under desk top to hold books and supplies. Chair sold seperately. Frame available in gray only. 28¹/₂"W x 17¹/₂"D x 27"H. Wt. 28 lbs. \$155



LKCP15 - Plastic chair available in bright blue, gray, yellow, red and green. Size 16"W x 15"D x 15" seat height. Wt. 8 lbs. \$50

LKCP14 - 14" height \$32

LKCP12 - 12" height \$28

LKCP11 - 11" height \$26

LKCP10 - 10" height \$24

Versatile Workcenters

Hi-Tech Units Feature:

- Strong heavy gauge tubular steel construction.
- Heavy duty 1" shelves with resilient vinyl T-molding.
- Thermally fused laminate shelves coated with mar-resistant, durable, melamine finish.
- Choice of frame color - Black or gray baked-on powder coat paint finish.
- Shelves adjustable in 1" increments; allows moving and adding shelves.
- Optional 3 MOV high spike surge suppressing electric. 3-outlet, 15' cord, UL and CSA listed. TLES
- Open shelf design provides easy access and spacious work surface.
- 2" twin wheel casters available in place of glides at no extra charge. Add suffix "C2S" to model number. Example: TL72C2S. Casters standard on most models.
- Assembly required.

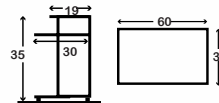

TL6035 • 60"W x 30"D x 35"H • 103 Lbs.

\$795

Units pictured with optional **TLCPU** CPU brackets for TL models. Order separately.



TLCPU \$128

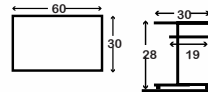

TL6028 • 60"W x 30"D x 28"H • 100 Lbs.

\$795

TL6035 - 60" wide workstation with two shelves and 2" casters, two with locking brake. Available in ebony granite shelf color only. Specify black or gray frame. Assembly required. Maximum height 35". Wt. 103 lbs.

TL6028 - Same features as above with 28" maximum height. Wt. 100 lbs.

TL6050 - 60" wide editing center. Complete with 2" casters, two with locking brake. Specify black or gray frame. Assembly required. Wt. 131 lbs.

TL4850 - Same as above but 48" wide. Wt. 108 lbs

Accessories



TL4 - 4" dual wheel furniture caster. Not recommended for high mobility. Wt. 5 lbs. In lieu of standard casters, add suffix TL4. \$84



TL5B - Swing-out chrome wire storage basket. Attach to right leg tube only. Adjusts up/down in 1" increments. 13" x 10 1/2" x 4". Wt. 4 lbs. \$63

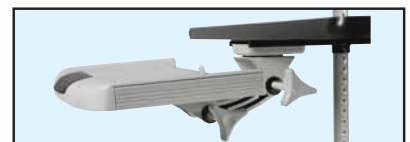

TLKB - Pull-out keyboard shelf. Fits all Hi-Tech workstations. Dual adjustment for added comfort and convenient covered storage compartment. Wt. 8 lbs. \$156

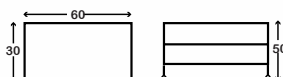

TL6050 • 60"W x 30"D x 50"H • 131 Lbs. \$923



TL4850 • 48"W x 30"D x 50"H • 108 Lbs.

\$707

Hi-Tech

Hi-Tech Computer Workstations

TL4828 - 48" wide workstation with two shelves and 2" casters, two with locking brake. Specify color(s) when ordering, see Color Key on page 26. Choose black or gray frame. Assembly required. Maximum height 28". Wt. 85 lbs.

TL4835 - Same features as above with 35" maximum height. Wt. 87 lbs.

TL3628 - 36" wide workstation with two shelves and 2" casters, two with locking brake. Specify color(s) when ordering, see Color Key. Choose black or gray frame. Assembly required. Maximum height 28". Wt. 69 lbs.

TL2435RR - 24" wide workstation with two shelves and 2" casters, two with locking brake. Specify color(s) when ordering, see Color Key. Choose black or gray frame. Assembly required. Maximum height 35". Wt. 57 lbs.

TL2428YY - 24" wide workstation with 2 shelves and 2" casters, two with locking brake. Specify color(s) when ordering, see Color Key. Choose black or gray frame. Assembly required. Maximum height 28". Wt. 57 lbs.

TL28 - Same as above without bottom shelf. Wt. 26 lbs.

TL3635 - 36" wide workstation with two shelves and 2" casters, two with locking brake. Specify color(s) when ordering, see Color Key. Choose black or gray frame. Assembly required. Maximum height 35". Wt. 71 lbs.

TL48W - 48" wide wheelchair workstation. Shelf height adjusts in 1" increments. Complete with 2" casters, two with locking brake. Specify color(s) when ordering, see Color Key on page 26. Specify black or gray frame. Assembly required. Wt. 66 lbs.

TL36W - 36" wide wheelchair workstation with same features as above. Wt. 58 lbs.

Ordering Instructions: When ordering Luxor's Hi-Tech colored models, please use the following codes for assistance:
Color Key: R=Red, B=Blue, G=Green, Y=Yellow

*Traditional Ebony Granite shelf color, specify base color only.



Example :

TL4828 BG

Top Shelf Color
Bottom Shelf Color



TL4835

TL4828

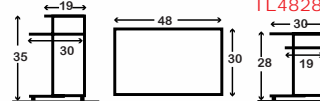

TL4828 • 48"W x 30"D x 28"H • 85 Lbs. \$582

TL4835 • 48"W x 30"D x 35"H • 87 Lbs. \$582



Shown with optional TLCPU, CPU holder. Order separately.

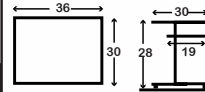

TL3628 • 36"W x 30"D x 28"H • 57 Lbs. \$475

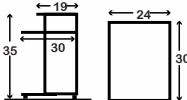

TL2435 • 24"W x 30"D x 35"H • 57 Lbs. \$419



Shown with optional TLCPU, CPU holder. Order separately.

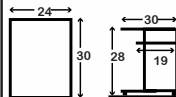

TL2428 • 24"W x 30"D x 28"H • 57 Lbs. \$419

TL28 • Same w/out bottom shelf • 26 Lbs. \$589



Shown with optional TLWS36 \$85 wire leg shelf, and TLKB (see page 39) adjustable keyboard shelf.

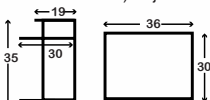

TL3635 • 36"W x 30"D x 35"H • 71 Lbs. \$475



Shown with optional S36 \$88 top shelf. Order separately.

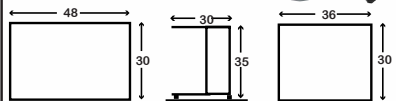

TL48W • 48"W x 30"D x 35"H • 66 Lbs. \$521

TL36W • 36"W x 30"D x 35"H • 58 Lbs. \$393

Computer Centers/Printer

These compact adjustable computer centers are extremely mobile and will accommodate a complete system. These space-saving units incorporate the same high quality features as listed on page 39.

TL2452 - 24" wide computer center with two shelves, and 2" casters, two with locking brake. Specify black or gray frame. Assembly required. Maximum height 50". Wt. 64 lbs.

TL2453 - Same as above but three shelves. Wt. 79 lbs.

TL2458 - 24" wide computer center with four shelves, and 2" casters, two with locking brake. Specify black or gray frame. Assembly required. Maximum height 56". Wt. 90 lbs.

TL2454 - Same as above but 50" maximum height. Wt. 87 lbs.

TL1837 - 18" wide, 37" tall, multiple use mobile workstation. Ideal for laptop computers and overhead projectors. Complete with 2" furniture casters, two with locking brake. Specify black or gray frame. Assembly required. Wt. 43 lbs.

TL16PS - 22" wide printer stand with two shelves, and 2" casters, two with locking brake. Black frame only. Designed to fit under 35" Hi-Tech units and other selected models. Assembly required. Wt. 25 lbs.

TL24P4 - 24" wide printer stand with four shelves, and 2" casters, two with locking brake. Specify black or gray frame. Assembly required. Wt. 74 lbs.

TLMS - Optional mouse shelf. \$61

TLPC - Optional storage basket. \$32



TL2452 • 24"W x 19"D x 50"H • 64 Lbs. \$475

TL2453 • Same as TL2452 w/3 shelves • 79 Lbs. \$567



TL2458 • 24"W x 30"D x 56"H • 90 Lbs. \$620

TL1837 • 17"W x 23"D x 37"H • 43 Lbs. \$351



TL16PS • 22"W x 16"D x 16 1/2"H • 25 Lbs. \$232

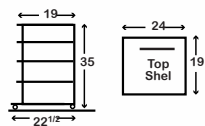

TL24P4 • 24"W x 19"D x 35"H • 74 Lbs. \$587

Hi-Tech

Computer Centers/Printer

TL4835MM - 48" wide multi-media workstation with terminal/monitor platform. Complete with 2" casters, two with locking brake. Specify black or gray frame. Assembly required. Wt. 122 lbs.

TL4828MM - Same as above without terminal/monitor platform. Maximum height 28". Wt. 81 lbs.

TLOH38 - 36" high stand-up overhead projector table with side shelves to hold transparencies and other supplies. Complete with 2" furniture casters, two with locking brake. Specify black or gray frame. Assembly required. Wt. 48 lbs.

TLOH29 - 29" high sit-down overhead projector table with same features as above. Wt. 47 lbs.

TL37TV - 37" high audio visual table with two shelves. Complete with 2" furniture casters, two with locking brake. Black frame color. Assembly required. Wt. 46 lbs.

S24 - Optional 24" wide shelf. Ebony granite color. Assembly required. Wt. 16 lbs.

TL1830 - 18" wide workstation. Complete with 2" twin wheel furniture casters, two with locking brake. Specify black or gray frame. Assembly required. Wt. 40 lbs.

TL1830MD - Same as above with slide-out media drawer. Wt. 44 lbs.

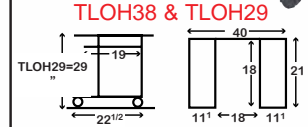
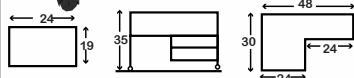

TL4835MM • 24"W x 19"D x 35"H • 122 Lbs. \$875	TLOH38 • 40"W x 21"D x 36"H • 48 Lbs. \$464
TL4828MM • w/out terminal platform • 81 Lbs. \$721	TLOH29 • 40"W x 21"D x 29"H • 47 Lbs. \$464

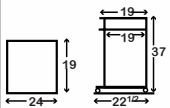

TL37TV • 24"W x 19"D x 37"H • 46 Lbs. \$399	S24 • Optional 24"W shelf • 16 Lbs. \$79
--	---

Shown with optional **TLMS** mouse shelf.



Shown with optional **TL4** casters.

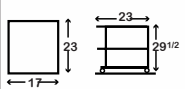

TL1830 • 17"W x 23"D x 29 1/2"H • 40 Lbs. \$356
--



Line drawings for the Hi-Tech section are on page 43.

LUXOR SERVICES

SERVICE

Satisfaction guaranteed means just that! We want you and your customer to be happy with our products. If there is a problem we want to hear about it. Luxor also has a toll-free number for your customers' use. It's a direct line to our Customer Service Department which allows us to solve problems for you. You may give this number to your customers, if you wish. The number is **1-800-323-4656**.

***Satisfaction
Guaranteed***

SEND US

We have a toll-free fax number, 1-800-327-1698, which may be used throughout the U.S. including Alaska, Hawaii and in Canada, or you can e-mail orders to: orders@luxorfurn.com.

A FAX OR EMAIL

Faxing and e-mailing orders speeds delivery and saves you money. You can e-mail questions to: sales@luxorfurn.com.



DELIVERY

We warehouse all of our products and ship promptly. Speedy delivery keeps your customers happy and turns your profit dollars more quickly. If there should be a delay, we'll call and keep you informed.



NEW MARKET

Luxor offers products which have application in other markets. Example: We manufacture a wide range of hospital carts, restaurant and janitorial carts, in addition to our expanded line of children's furniture. Many of your customers are prospects for these products and we can help you pursue these new market sales. Write for brochures and confidential dealer pricing. Luxor will also customize a flyer for your company. You pick the products - we design and print them free of charge!

OPPORTUNITIES

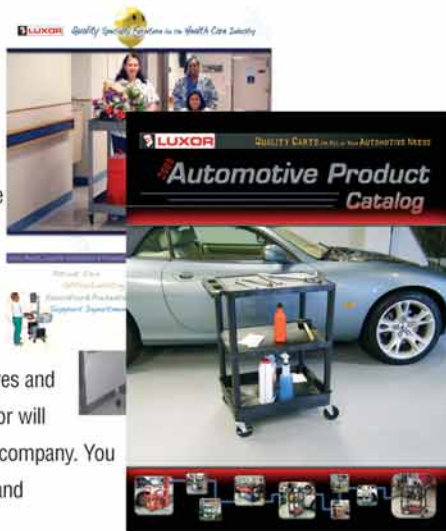

CUSTOM TABLES

AND CABINETS

Call us if you have a requirement for a custom table or cabinet. We can, and do, modify our products for special applications. Modifications usually affect cost, the lead time required for delivery and are most commonly done on large quantity requirements. But don't hesitate to call with your ideas. We want to hear from you.



SHOW

SAMPLES

- Sample products provided for your showroom or convention display.
- Samples are 70% off list price or free freight!
- We can ship to you or direct to a convention hall.
- If stand up easel signs will help sell, they are available also.



CATALOGS



The Luxor full-line catalog is 84 pages in full color. It's available in quantity free of charge. Imprinting is also available. We'll even do custom layouts and photography at no cost to you. To put our marketing service people to work for you, just call.

ANYTHING

ELSE

Tell us if there's other service Luxor can provide or action we can take to help you sell and profit. We love new ideas and welcome suggestions.

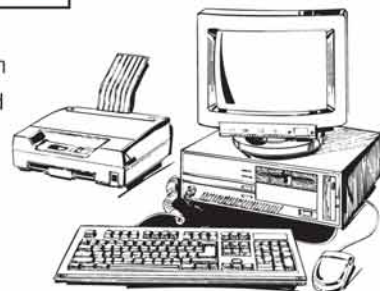

FREE

Luxor Literature Request Form

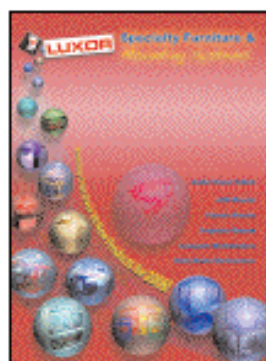

LUXOR FULL LINE CATALOG

This 84 page full color catalog displays Luxor's full line of audio visual and computer furniture. Order by quantity:

Price & Version: _____

Unpriced: _____



LUXOR HEALTHCARE CATALOG

This 44 page full color catalog displays Luxor's complete line of furniture designed for healthcare, food service, restaurant, and maintenance applications. Order by quantity:

Price & _____



LUXOR AUTOMOTIVE CATALOG

This 20 page full color catalog displays Luxor's complete line of quality carts for automotive, shop, and maintenance applications. Order by quantity:

Unpriced: _____

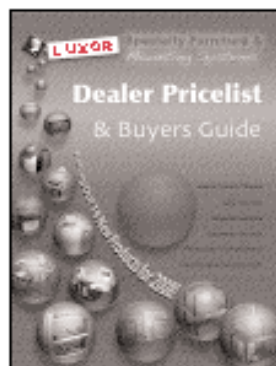

LUXOR PRICE LIST

20 page complete price list of Luxor's full line of audio visual and computer furniture. Order by quantity:



LUXOR CHILDREN'S CATALOG

This 16 page full color catalog displays Luxor's complete line of computer and audio visual furniture specially designed for early childhood and primary education. Order by quantity:

Unpriced: _____



LUXOR CUSTOM FLYER PROGRAM

Luxor offers the chance to have a flyer designed for an individual company's need. This brochure explains how you can participate in this spectacular offer. Check below.

Yes, I am interested in Luxor's Custom Flyer Program: _____

Get your **FREE** Luxor Literature today.

Fill in the information and fax toll-free at **1-800-327-1698**.

Or E-mail To: sales@luxorfurn.com

Ship to:

Company: _____ Address: _____

Contact Name: _____ Phone/Fax/E-mail: _____



THE LUXOR GUARANTEE

All Luxor products are provided with a lifetime guarantee. Luxor will replace or repair any unit which is found to be damaged in transit or is unsatisfactory in use. This guarantee is for the life of the product provided the product is used for its intended purpose and used with weight loads not exceeding those recommended. Since rental applications do not fall under the category of normal usage, Luxor will be unable to provide the Lifetime Guarantee on units used for rental applications. We will, however, make parts and/or entire units available at a special purchase price upon request.

HOW TO ORDER

Call Toll Free: 1-800-323-4656
Toll Free Fax: 1-800-327-1698
Email: sales@luxorfurn.com
Email: orders@luxorfurn.com

Mail: P.O. Box 830, Waukegan, Illinois 60079-0830

Large Quantity Orders: Luxor ships most quantity orders within 5 days of receipt. However, larger quantity orders may be acknowledged with a longer lead time. If a specific shipping date is an important consideration, call (toll free) to confirm product availability. Minimum order limitations on stocking prices for Universal Table Accessories. See page 18.

DISCOUNT POLICY

All prices are F.O.B. the Luxor warehouse in Waukegan, Illinois and/or Trussville, Alabama. Dealer pricing is determined by the total quantity ordered. Orders may be combined for maximum discount. All products (except accessories) can be mixed to count toward the total quantity.

Freight Paid Pricing: Luxor will quote prices Freight Paid, for any order upon request. This pricing can be guaranteed for a specific period of time. Please call for these quotations.

All pricing is subject to change upon notice. All prices are stated in U.S. Dollars.

Terms: Net 30 days. Requests for special terms should be approved prior to processing your order.

Return Goods: Merchandise should not be returned **without written authorization** and should be sent prepaid. A 25% restocking charge applies. **Units returned unauthorized will receive a maximum of 50% credit. All returns must be made within 60 days.**

Order Cancellation: A 10% order cancellation fee will be charged on all cancelled orders.

SHIPPING INFORMATION

Drop Shipments: Luxor will drop ship any order at **no extra charge**. All orders received on the same day are considered as one to give you the maximum discount.

Freight Charges: UPS shipments are pre-paid and added to your invoice. Shipments via motor freight to your company are made freight collect. If you wish service otherwise, please specify on your orders. Drop shipments via motor freight are billed directly to you by the carrier. Your purchase order number and our acknowledgement number appear on the carrier's bill to aid in matching our bill with the freight bill.

Carrier Selection: If you have a carrier preference, please mark each order to indicate this. Luxor will ship by the carrier you specify, if possible. If not specified, Luxor will ship the most economical way.

SATISFACTION GUARANTEE

Luxor products are guaranteed to be free of manufacturing defects and to be of the quality represented in Luxor catalogs. If any product is determined to be unsatisfactory, contact Luxor's Customer Service Department for an immediate return authorization. No restocking charge will apply when a product is being returned under this satisfaction guarantee. It is our intention that you be completely satisfied with Luxor products and service. Therefore, all questions are resolved promptly and fairly. For future reference, all Luxor products are provided with a Lifetime Guarantee. Luxor will replace or repair any unit which is found to be damaged in transit or is unsatisfactory in use. This guarantee is for the life of the product provided the product is used for its intended purpose and used with weight loads not exceeding those recommended. Since rental applications do not fall under the category of normal usage, Luxor will be unable to provide the Lifetime Guarantee on all units used for rental applications. We will, however, make parts and/or entire units available at a special purchase price upon request.

All Luxor products are inspected carefully and shipped in packaging which has been tested and approved by the Motor Freight Carriers Association.

If damage in transit occurs, it is generally the motor carrier's responsibility and must be reported promptly. Failure to report freight damage make any loss the consignee's responsibility.

Luxor will assist in pursuit of freight claims. However, you or your customers must do the following:

1. Do not sign "clear" for a shipment when there is any noticeable damage to the cartons or to the product. Visible damage must be noted on the carrier's bill of lading before signing. Failure to do this negates the possibility of claim.
2. Inspect all shipments immediately for concealed damage. If there is concealed damage, contact the carrier and request a Damage Inspection. This must be done within 15 days of delivery. Failure to report concealed damage within 15 days also negates the possibility of claim.

"Concealed Damage" - Concealed damage occurs when a product is damaged even though the carton appears to be in good condition. This kind of damage occurs occasionally. It is the motor carrier's responsibility and must be reported promptly.





See Page 27

LCTL2428 • 28"W x 29"D x 28"H • 36 Lbs. \$164



See Page 27

LCTL1830 • 18"W x 21"D x 30"H • 29 Lbs. \$112



See Page 27

LCTL2435 • 24"W x 29"D x 35"H • 37 Lbs. \$168



See Page 27

LCTL29 • 24"W x 29"D x 28"H • 31 Lbs. \$136



See Page 27

LCTL2452 • 24"W x 29"D x 52"H • 46 Lbs. \$232



See Page 28

LHDAWS • 43"W x 29½"D x 19½"-29½"H • 81 Lbs. \$450



See Page 28

LACT2030 • 47"W x 27½"D x 20½"-30½"H • 63 Lbs. \$298



See Page 30

UCC1 • 22½"W x 19½"D x 37½"H • 73 Lbs. \$249



See Page 33

MWC54 • 42"W x 24"D x 53½"H • 177 Lbs. \$855

New Multi-Purpose Carts!
Each cart on this page is available in two sizes!

SST2L - Two tub stainless steel transport cart. Top and bottom tubs are 4" deep. Includes four 4" locking casters. measures 35¹/₂"W x 19"D x 35¹/₂"H \$330

SST2S - Same features as above with dimensions of 33¹/₂"W x 17¹/₂"D x 35¹/₂"H. \$292



MRCS1 - Two tub steel transport cart. Top tub is 10"D, bottom tub is 3" deep. Includes two 10" big wheels and two 4" locking casters. Light gray powder coat paint finish. measures 18"W x 16"D x 39"H. \$259

MRCS2 - Same features as above with dimensions of 38¹/₂"W x 16"D x 39"H. \$309



MRCW2 - Two tub steel wire transport cart. Top tub is 10"D, bottom tub is 7" deep. Includes two 10" big wheels and two 5" locking casters. Light gray powder coat paint finish. measures 31"W x 17"D x 39"H. \$287

MRCW1 - Same features as above with dimensions of 36¹/₂"W x 17"D x 39"H. \$265



Multi-Purpose

Stainless Steel Carts



LICWT3014 • 24"W x 14"D x 32"H • 34 Lbs. \$169



LICWT2918 • 30"W x 18"D x 30"H • 33 Lbs. \$193



L100S2 • 26"W x 16"D x 35"H • 27 Lbs. \$224



L100S3 • 26"W x 16"D x 35"H • 35 Lbs. \$284

LICWT3014 - Fully adjustable three shelf chrome wire tub cart. Shelves adjust in 1" increments Ideal for industrial, healthcare, food service, or restaurant applications. Unit comes with one 3½" deep tub shelf and two 1" deep shelves. Complete with 3" casters, two with locking brake. 24"W x 14"D x 32"H. Wt. 34 lbs.

LICWT2918 - Same as LICWT3014 with measurements of 30"W x 18"D x 30"H and top tub 5" deep. Wt. 33 lbs.

L100S2 - All stainless steel two shelf cart with a clearance of 24" between shelves. Ideal for light weight industrial, healthcare, food service, or restaurant applications. Complete with 4" NSF casters, two with locking brake. 26"W x 16"D x 35"H. Wt. 27 lbs.

L100S3 - Same as L100S2 except with three shelves and a 12" clearance between shelves. Wt. 35 lbs.



Multi-Purpose

Wire Carts/Packing Station

LICW4218 - Fully adjustable, mobile wire computer workstation. Includes pull-out keyboard shelf, CPU tower holder measures 9"W x 18"D and swing-out mouse shelf measures 9¹/₂"W x 9¹/₂"D. Ideal for hospital and restaurant use. Complete with 3" casters, two with locking brake. 29¹/₂"W x 18"D x 42"H. Assembly required. Chrome color. Wt. 43 lbs.

LICW3018 - Same as LICW4218 except 32" H. Wt. 39 lbs.

LICWES - Optional extra shelf for LICW units. Wt. 9 lbs.

LWT970 - Easy transport wire dolly with white powder coat paint finish. Ideal for transporting cartons, mail, office supplies and accessories, or presentation materials. Comes complete with 6" pneumatic wheels. 34"W x 17"D with a handle. Wt. 30 lbs.

LIWPS - Open wire packing station. Galvanized work surface combines with open wire shelves to give you an extremely strong and durable packing bench. Work surface is strong enough to support 500 lbs. Tough powdercoat finish wire shelves will not trap dirt and provide good air circulation and ventilation to supplies. Lower shelf holds up to 650 lbs. - ideal for storing heavy cartons or supplies. Two upper 60"W x 14"D adjustable shelves are included and support up to 150 lbs. each. Top shelf includes six 12¹/₂" adjustable dividers, middle shelf has a backstop to keep items secure. 60"W x 30"D x 34"H overall. Wt. 125 lbs.



LICW4218 • 29¹/₂"W x 18"D x 42"H • 43 Lbs. \$275

LICW3018 • 29¹/₂"W x 18"D x 32"H • 39 Lbs. \$246

LICWES • Extra Shelf • 9 Lbs. \$43

LWT970 • 34"W x 17"D x 30 Lbs. \$159



LIWPS • 60"W x 30"D x 34"H • 125 Lbs.

\$665

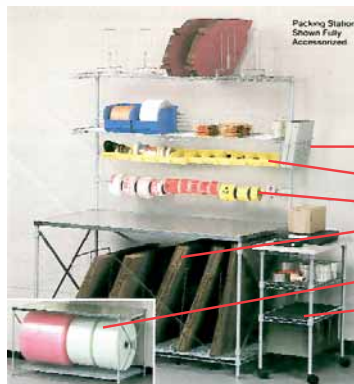

Optional Accessories For LIWPS:

- Utility Basket (**LIWUB**)
- Bin Rail (**LIWBR**)
- Reel Holder (**LIWRE**)
- Carton Divider (**LIWCD**) (Set of 5)
- Roll Holder (**LIWRO**)
- Scale Stand (**LIWSS**)

LIWUB • Utility Basket • 2 Lbs. \$28

LIWRE • Reel Holder • 3 Lbs. \$42

LIWRO • Roll Holder • 5 Lbs. \$42

LIWBR • Bin Rail • 10 Lbs. \$42

LIWCD • Carton Divider • 15 Lbs. \$135

LIWSS • Scale Stand • 28 Lbs. \$157

Multi-Purpose

Janitorial Carts



HL13 • 25"W x 25"D x 36¹/₂"H • 23 Lbs. \$169



JCB8 • 36"W x 17"D x 38"H • 31 Lbs. \$239

HL13 - Laundry cart folds for easy storage. Comes complete with an orange nylon laundry bag and 3" casters. Blue color. 25"W x 25"D x 36¹/₂"H. Assembly required. Wt. 23 lbs.

JCB8 - Heavy-duty three shelf janitor cart with an orange nylon trash bag. Top two shelves have a tray for supplies. Comes complete with 8" big wheels. 36"W x 17"D x 38"H. Clearance between bottom to middle shelf 13", middle to top shelf 16". Mop bucket and cleaning supplies not included. Gray color. Assembly required. Wt. 31 lbs.

JCB30 - Heavy-duty, three shelf janitor cart with black nylon trash bag. Top two shelves have tray for supplies. Complete with 8" big wheels and caster bumpers. Mop bucket and cleaning supplies not included. 32"W x 24"D x 48"H. Black color. Clearance between shelves 17¹/₂". Assembly required. Wt. 47 lbs.



JCB30 • 32"W x 24"D x 48"H • 47 Lbs. \$408



MSB42 • 32"W x 24"D x 42"H • 59 Lbs. \$366

MSB42 - Three shelf housekeeping cart with black nylon trash bag. Complete with 8" big wheels and caster bumpers. Black color. 32"W x 24"D x 42"H. Clearance between shelves 11" and 19". Assembly required. Wt. 59 lbs.

JCB40 - Heavy-duty, four shelf janitor cart with black nylon trash bag. Top two shelves have space for supplies. Complete with 8" big wheels and caster bumpers. Mop bucket and cleaning supplies not included. 32"W x 24"D x 50"H. Black color. Clearance between shelves 8", 17", and 11¹/₂". Assembly required. Wt. 61 lbs.

LPD300 - Large platform dolly constructed of steel frame and non-skid vinyl deck surface. 32¹/₂" handle folds down for compact storage. Platform size 25" x 35". Includes 4" casters. 600 lb. capacity.



JCB40 • 32"W x 24"D x 50"H • 61 Lbs. \$494



LPD300 • 25"W x 35"D • 41 Lbs. \$197

SPD140 - Small platform dolly constructed of steel frame and non-skid vinyl deck surface. 32¹/₂" handle folds down for compact storage. Platform size 19" x 29". Includes 4" casters. 400 lb. capacity.



SPD140 • 19"W x 29"D • 23 Lbs. \$86

PPD200 - Plastic heavy duty dolly. Deck size 16" x 24". Includes 3" poly-swivel casters. 800 lb. capacity.



PPD200 • 16"W x 24"D • 14 Lbs. \$80



Multi-Purpose

Bussing/Serving Carts

BC55 - Large five shelf banquet serving cart with 4" swivel casters, two with locking brake. Specify putty, black, or gray color. 24"W x 32"D x 49"H. Clearance between shelves 8". Assembly required. Wt. 73 lbs.

BCB55 - Same as above with 8" big wheels. Wt. 77 lbs.

BC45 - Four shelf banquet cart with 4" swivel casters, two with locking brake. Specify putty, black, or gray color. 18"W x 24"D x 36"H. Clearance between shelves 8^{3/4"}. Assembly required. Wt. 29 lbs.

BCB45 - Same as above with 8" big wheels. Wt. 35 lbs.

SC14 - Open shelf serving/bussing cart with plastic polypropylene shelves and aluminum legs. Comes standard with 3" casters. Gray color. 40"W x 19^{3/4"}D x 34"H. Clearance between shelves 11". Assembly required. Wt. 48 lbs.

SCB30 - Open shelf serving cart with side shelf. Includes 3-outlet, 15' U.L. and C.S.A. listed electric assembly, 8" big wheels and caster bumpers. Specify putty, black, or gray color. 24"W x 18"D x 33"H. Clearance between shelves 12". Assembly required. Wt. 40 lbs.

SCB30C - Three shelf serving cart with locking cabinet and side shelf. Includes 3-outlet, 15' U.L. and C.S.A. listed electric assembly, 8" big wheels, and caster bumpers. Specify putty, black, or gray with walnut cabinet. 24"W x 18"D x 33"H. Clearance between shelves 6^{1/4"} and 17^{3/4"}. Assembly required. Wt. 62 lbs.

IBC4 - Open 4 shelf serving/bussing cart with plastic polypropylene shelves and brushed aluminum legs. Comes standard with 3" casters. Gray color. 40"W x 19^{3/4"}D x 47^{3/4"}H. Clearance between shelves 11". Assembly required. Wt. 61 lbs.

IBC5 - Same as above with 5 shelves. 61^{1/2"}H. Wt. 74 lbs.

Accessories For IBC4 & IBC5

IPTS - Plastic tub with lid. 13^{1/2"}W x 16"D x 5"H. Wt. 2 lbs. \$34

ISB - Silverware bin, hangs from side of cart. Wt. 1 lbs. \$19

ITB - Trash bin, hangs from side of cart. Wt. 3 lbs. \$39



BC55 • 32"W x 24"D x 49"H • 73 Lbs. \$466

BCB55 • With 8" big wheels • 77 Lbs. \$530

BC45 • 24"W x 18"D x 36"H • 29 Lbs. \$218

BCB45 • With 8" big wheels • 35 Lbs. \$284



SC14 • 40"W x 19^{3/4"}D x 34"H • 48 Lbs. \$246



SCB30 • 24"W x 18"D x 33"H • 40 Lbs. \$318



SCB30C • 24"W x 18"D x 33"H • 62 Lbs. \$583

Accessories sold separately (see left).



IBC4 • 40"W x 19^{3/4"}D x 47^{3/4"}H • 61 Lbs. \$398



IBC5 • 40"W x 19^{3/4"}D x 61^{1/2"}H • 74 Lbs. \$496

Multi-Purpose

Bussing/General Purpose Carts

IBCFA - Serving/bussing cart with plastic polypropylene shelves and aluminum legs. A wide range of accessories can be attached to this cart to meet almost any food service need. Comes with 3" casters, two with locking brake.

MTC30DL/N - Three shelf general purpose utility cart with tub middle & top shelves, and flat bottom shelf. Includes 6 removable tray dividers which can be arranged in numerous positions for increased flexibility, un-hinged plastic lid, and 4" casters, two with locking brake. 24"W x 15^{3/4}"D x 33"H. Black color. Wt. 36 lbs.

MTC30DLL/N - Three shelf general purpose utility cart with tub middle & top shelves, and flat bottom shelf. Includes 6 removable tray dividers which can be arranged in numerous positions for increased flexibility, hinged locking plastic lid, and 4" casters, two with locking brake. 24"W x 15^{3/4}"D x 33"H. Black color. Wt. 37 lbs.

MTC40DN - Four shelf general purpose utility cart with tub middle & top shelves, and flat bottom shelf. Includes 6 removable tray dividers which can be arranged in numerous positions for increased flexibility, and 4" casters, two with locking brake. 24"W x 15^{3/4}"D x 46^{1/2}"H. Black color. Wt. 46 lbs.

MTC40DLL/N - Same as above with locking plastic lid on top shelf. Black color. Wt. 48 lbs.

LPT42 - Stand-up tool/utility cart with flat work surface area for convenience, large tub base shelf for plenty of storage, and a small top tub shelf for additional parts and accessories. Comes with 4" casters, two with locking brake. 32"W x 24"D x 42"H. Assembly required. Wt. 51 lbs.

LPT44 - Same as above with an additional middle tub shelf for plenty of storage. 32"W x 24"D x 44"H. Assembly required. Wt. 54 lbs.



Locking lid (MTCLL) and non-locking lid (MTCL) available for all MTC, LPT42, and LPT44 models.



IBC with no accessories



ISD - Silverware Drawers (2)

ITB - Trash Bin

IPTS - Plastic Tub With Lid



IEP - Side and back enclosure panels.



ISB - Silverware Bin

IBCFA fully accessorized

IEP - Side and back enclosure panels can be mounted between bottom and middle or middle and top shelf. \$68

ISB - Silverware bin hangs from retaining lip on top or middle shelf. \$19

ISD - Two silverware drawers. Slide into existing mount under top shelf. \$41

ITB - Trash bin hangs from retaining lip on top shelf. \$39

IPTS - Plastic tub with lid. Two tubs can fit side by side on any shelf. \$34

IBC • 28"W x 17"D x 35^{1/2}"H • 50 Lbs. \$249

\$249

IBCFA • 28"W x 17"D x 35^{1/2}"H • 65 Lbs. \$470

\$470



MTC40DN • 24"W x 15^{3/4}"D x 46^{1/2}"H • 46 Lbs. \$259

\$259

MTC40DLL/N • 24"W x 15^{3/4}"D x 46^{1/2}"H • 48 Lbs. \$303

\$303



LPT42 • 32"W x 24"D x 42"H • 51 Lbs. \$509

\$509



LPT44 • 32"W x 24"D x 44"H • 54 Lbs. \$567

\$567

Multi-Purpose

ATC332 - Three shelf compact adjustable utility cart constructed of blow-molded plastic with metal frame. 22"W x 15 1/2"D x 32"H. Complete with 3" heavy duty casters, two with locking brake. Red color only. Wt. 23 lbs.

ATC232 - Same as above, except 2-shelf model. Wt. 20 lbs.



ATC332 • 22"W x 15 1/2"D x 32"H • 23 Lbs.

\$203

ATC232 • 22"W x 15 1/2"D x 32"H • 20 Lbs.

\$177

- Push handle molded into top shelf.
- Easy and quiet rolling.
- Easy assembly with rubber mallet included.
- Available in 6 tub colors and 9 leg colors
- Carts available with 2, 3 or 4 shelves.
- Lifetime warranty!

TC and STC tub carts now available in 6 colors!

Legs now available in 9 colors!

To specify shelf color, add the prefix listed below to the model number. Example: STC111 with red shelves= **RD**STC111



Color	Code
Green	GN
Red	RD
Black	BK
Putty	PY
Blue	BU
Gray	GY



To specify leg color, add the suffix listed below to the model number. Example: STC111 with red legs= STC111**RD**

Color	Red	Orange	Yellow	Green	Blue	Purple	Putty	Gray	Black
Code	RD	OR	YW	GN	BU	PR	PY	GY	BK

Multi-Purpose

Colored TC & STC Carts



BUSTC111PR • 24"W x 18"D x 40½"H • 29 Lbs. \$257



RDSTC111YW • 24"W x 18"D x 40½"H • 29 Lbs. \$257

BUSTC111PR - Three tub shelf utility cart with 4" casters, two with locking brake. 24"W x 18"D x 40¹/₂"H. 2³/₄" deep tubs. Shelf clearance 12". Blue shelves with purple legs. Wt. 29 lbs.

RDSTC111YW - Three tub shelf utility cart with 4" casters, two with locking brake. 24"W x 18"D x 40¹/₂"H. 2³/₄" deep tubs. Shelf clearance 12". Red shelves with Yellow legs. Wt. 29 lbs.

RDSTC221BU - Top and middle flat shelves and bottom tub shelf utility cart with 4" casters, two with locking brake. 24"W x 18"D x 35¹/₂"H. 2³/₄" deep tubs. Shelf clearance 12". Red shelves with blue legs. Wt. 26lbs.



RDSTC221BU • 24"W x 18"D x 40½"H • 29 Lbs. \$230



BUSTC121GY • 24"W x 18"D x 38"H • 28 Lbs. \$239

BUSTC121GY - Top and bottom, tub shelf, and middle flat shelf utility cart with 4" casters, two with locking brake. 24"W x 18"D x 38"H, 2³/₄" deep tubs. Shelf clearance 12". Blue shelves with gray legs. Wt. 28 lbs.

GNSTC111GN - Three tub shelf utility cart with 4" casters, two with locking brake. 24"W x 18"D x 40¹/₂"H. 2³/₄" deep tubs. Shelf clearance 12". Green shelves with Green legs. Wt. 29 lbs.

GNTC11BK - Two tub shelf utility cart with 4" casters, two with locking brake. 32"W x 24"D x 37¹/₂"H. 2³/₄" deep tubs. Shelf clearance 25". Green tubs with black legs. Wt. 41 lbs.



GNSTC111GN • 24"W x 18"D x 40½"H • 29 Lbs. \$257



GNTC11BK • 32"W x 24"D x 37½"H • 41 Lbs. \$378

All STC and TC carts on the next two pages are available with colored legs and shelves. Use the codes on the previous page to specify colors.

Multi-Purpose

24" x 18" Heavy Duty Utility Carts

- Push handle molded into top shelf.
- Easy and quiet rolling.
- Easy assembly with rubber mallet included.
- Available in black, putty or gray color.
- Carts available with 2, 3 or 4 shelves.
- Lifetime warranty!

STC11 - Two tub shelf utility cart with 4" casters, two with locking brake. 24"W x 18"D x 38^{1/2}"H. 2^{3/4}" deep tubs. Shelf clearance 26". Specify black, gray or putty color. Wt. 23 lbs.

STC221 - Top and middle flat shelves and bottom tub shelf utility cart with 4" casters, two with locking brake. 24"W x 18"D x 35^{1/2}"H. 2^{3/4}" deep tubs. Shelf clearance 12". Specify black, gray or putty color. Wt. 26lbs.

STC111 - Three tub shelf utility cart with 4" casters, two with locking brake. 24"W x 18"D x 40^{1/2}"H. 2^{3/4}" deep tubs. Shelf clearance 12". Specify black, gray or putty color. Wt. 29 lbs.

STC1111 - Four tub shelf utility cart with 4" casters, two with locking brake and 24"W x 18"D x 46^{3/4}"H, 2^{3/4}" deep tubs. Shelf clearance 8^{3/4}". Specify black, gray or putty color. Wt. 38 lbs.

STC121 - Top and bottom, tub shelf, and middle flat shelf utility cart with 4" casters, two with locking brake. 24"W x 18"D x 38"H, 2^{3/4}" deep tubs. Shelf clearance 12". Specify black, gray or putty color. Wt. 28 lbs.

STC211 - Top flat shelf and middle and bottom tub shelves utility cart with 4" casters, two with locking brake. 24"W x 18"D x 38"H. 2^{3/4}" deep tubs. Shelf clearance 12". Specify black, gray or putty color. Wt. 28 lbs.



Options

LPCSA - 3-outlet, 15' electrical assembly. UL & CSA listed. Wt. 3 lbs. \$95



STBW/LTBW - 8" big wheel assembly for STC \$67 and TC models. \$91



C51 - 5" casters in lieu of 4" casters. \$37
As a separate unit:
C5 - \$68



Top shelf reinforced with aluminum bar!



STC11 • 24"W x 18"D x 38^{1/2}"H • 23 Lbs. \$190

STC221 • 24"W x 18"D x 40^{1/2}"H • 29 Lbs. \$189



STC111 • 24"W x 18"D x 40^{1/2}"H • 29 Lbs. \$212

STC1111 • 24"W x 18"D x 46^{3/4}"H • 38 Lbs. \$261

All STC and TC carts now available in 6 shelf colors and 9 leg colors! see page 52.



STC121 • 24"W x 18"D x 38"H • 28 Lbs. \$207

STC211 • 24"W x 18"D x 38"H • 28 Lbs. \$207

Model #		Colors	Shelf Clearance	Height	Weight	Price
STC12		Black, Gray, Putty	26"	36"	21 lbs.	\$173
STC21		Black, Gray, Putty	26"	36"	24 lbs.	\$173
STC112		Black, Gray, Putty	12"	38"	28 lbs.	\$207
STC122		Black, Gray, Putty	12"	35 1/2"	23 lbs.	\$195
STC212		Black, Gray, Putty	12"	35 1/2"	28 lbs.	\$195
STC2111		Black, Gray, Putty	8 3/4"	44 1/2"	38 lbs.	\$256

Multi-Purpose



All shelves reinforced with two aluminum bars!



TC11 • 32"W x 24"D x 37¹/₂"H • 41 Lbs.

\$327

TC211 • 32"W x 24"D x 37"H • 60 Lbs.

\$421

KE

TC = 24"D x 32"W Cart
STC = 18"D x 24"W Cart

- 1 = Tub Shelf
- 2 = Flat Shelf

Example:

STC112

Tub Cart Top Tub Middle Tub Bottom Flat Shelf Shelf Shelf Shelf



All STC and TC carts now available in 6 shelf colors and 9 leg colors! see page 52.



TC112 • 32"W x 24"D x 37"H • 55 Lbs.

\$421

TC111 • 32"W x 24"D x 38¹/₂"H • 61 Lbs.

\$435

TC1111 • 4 Tub shelves 44¹/₂"H • 76 Lbs.

\$534



PTC21 • 32"W x 24"D x 36"H • 67 Lbs.

\$615

TC21 • w/out pneumatic wheels 36"H • 43 Lbs.

\$315



PTC111 • 32"W x 24"D x 42¹/₂"H • 86 Lbs.

\$806

32" x 24" Heavy Duty Utility Carts

TC11 - Two tub shelf utility cart with 4" casters, two with locking brake. 32"W x 24"D x 37¹/₂"H. 2³/₄" deep tubs. Shelf clearance 25". Specify black, gray or putty color. Wt. 41 lbs.

TC211 - Top flat shelf and middle and bottom tub shelves utility cart with 4" casters, two with locking brake. 32"W x 24"D x 37"H. 2³/₄" deep tubs. Shelf clearance 11". Specify black, gray or putty color. Wt. 60 lbs.

TC112 - Top and middle tub shelf and bottom flat shelf utility cart with 4" casters, two with locking brake and 32"W x 24"D x 37"H, 2³/₄" deep tubs. Shelf clearance 11". Specify black, gray or putty color. Wt. 55 lbs.

TC111 - Three tub shelf utility cart with 4" casters, two with locking brake and 32"W x 24"D x 38¹/₂"H, 2³/₄" deep tubs. Shelf clearance 11". Specify black, gray or putty color. Wt. 61 lbs.

TC1111 - Four tub shelf utility cart with 4" casters, two with locking brake and 32"W x 24"D x 44¹/₂"H, 2³/₄" deep tubs. Shelf clearance 8". Specify black, gray or putty color. Wt. 76 lbs.

PTC21 - Top flat shelf and bottom tub shelf utility cart with pneumatic wheels, two with locking brake and 32"W x 24"D x 36"H, 2³/₄" deep tubs. Shelf clearance 25". Specify black, gray or putty color. Wt. 67 lbs.

TC21 - Top flat shelf and bottom tub shelf utility cart with 4" casters, two with locking brake and 32"W x 24"D x 36"H, 2³/₄" deep tubs. Shelf clearance 25". Specify black, gray or putty color. Wt. 43 lbs.

PTC111 - Three tub shelf utility cart with 8" pneumatic wheels, two fixed, two swivel with locking brake. 32"W x 24"D x 39"H. 2³/₄" deep tubs. Shelf clearance 11". Specify black, gray or putty color. Wt. 66 lbs.

SP8 - Solid rubber high profile semi-pneumatic tires. Add suffix "SP" to model number.



P8 - Air filled, non-marking pneumatic tires. Add suffix "P" to model number.

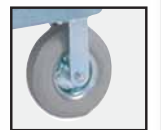

FR8 - Heavy duty 8" foam rubber casters. Add suffix "FR" to model number.



Model #		Colors	Shelf Clearance	Height	Weight	Price
TC12		Black, Gray, Putty	25"	36"	44 lbs.	\$315
TC121		Black, Gray, Putty	11"	37"	61 lbs.	\$427
TC122		Black, Gray, Putty	11"	35 ¹ / ₂ "	52 lbs.	\$405
TC212		Black, Gray, Putty	11"	35 ¹ / ₂ "	51 lbs.	\$405
TC221		Black, Gray, Putty	11"	35 ¹ / ₂ "	57 lbs.	\$405
TC2111		Black, Gray, Putty	8"	43"	76 lbs.	\$527

New Audio/Visual!



MB3624 - Reversible white/chalk board. Silver frame with white board on one side and green chalk board on the other. Both sides are magnetic. Includes 4 casters for easy mobility. Board size is 36"W x 24"H. \$158

MB4836 - Same as above with board measurements of 48"W x 36"H. \$232

MB6036 - Same as above with board measurements of 60"W x 36"H. \$265

MB7240 - Same as above with board measurements of 72"W x 40"H. \$291



Prestige

PS2633 - Projector table with gray laminate top and black frame. Left panel of table top tilts 30° using crank. Includes 2" casters two with brake. 29¹/₂"W x 19¹/₂"D x 23¹/₂"-33"H. \$265

Prestige

PS3800 - Mobile lectern with privacy panel. Dark gray laminate top with black powder coat painted steel frame and back panel. \$172



Prestige

PS3144 - Adjustable height lectern with gray laminate top and black frame. Includes four adjustable glides. \$135

Steel Overhead Projector Tables

- Roll formed steel shelves.
- 3-outlet, 15' UL and CSA listed electric assembly.
- 4" casters, two with brake.
- Powder coat paint finish. Black or gray color. OHT292S also available in putty.
- Side shelves drop down for easy mobility.
- Assembly required.

OHT29 - Sit-down, adjustable height, steel overhead projector table. Projector platform adjusts from 17 1/2" to 27 1/2". Complete with 3-outlet, 15' electric assembly, UL and CSA listed. Specify color, black or gray. Assembly required. Wt. 36 lbs.

OHT39 - Stand-up, adjustable height, steel overhead projector table. Projector platform adjusts from 27 1/2" to 37 1/2". Complete with 3-outlet, 15' electric assembly, UL and CSA listed. Specify color, black or gray. Assembly required. Wt. 47 lbs.

OHT292S - Sit down, adjustable height steel overhead projector table with additional lower storage shelf. Projector platform adjusts from 17 1/2" to 27 1/2". Complete with 3-outlet, 15' electric assembly, UL and CSA listed. Includes 4" casters, two with locking brake. Specify color black, putty or gray. Assembly required. Wt. 43 lbs.

AOHT1826 - Adjustable height mobile Projector table. Side shelves fold down for easy mobility. Projector platform measure 18"W x 17 1/2"D. Side shelves measure 12 1/4"W x 16"D and adjust from 26" to 39". Constructed of heavy-duty laminate with steel frame. Assembly required. Teak color/black frame. Wt. 32 lbs.

AVJOH Models Feature:

- Roll formed steel shelves.
- 3-outlet, 15' UL and CSA listed electric assembly.
- Projector platform well adjusts 0 to 10" in 1" increments.
- Powder coat paint finish. Black color.
- Assembly required.

AVJOH - Adjustable height steel overhead projector table for stand-up or sit-down use. Work surface adjusts from 25" to 45". Includes 4" casters, two with locking brake. Wt. 63 lbs.

AVJOH48T - 48" wide adjustable height steel overhead projector table with terminal platform. Terminal platform adjusts and tilts in 1" increments. Includes 4" casters, two with locking brake. Wt. 78 lbs.

AVJOH48 - Same as above without terminal platform. Wt. 72 lbs.



OHT29 • 39"W x 20 1/4"D x 29"H • 36 Lbs. \$351



OHT39 • 39"W x 20 1/4"D x 39"H • 47 Lbs. \$385



OHT292S • 39"W x 20 1/4"D x 29"H • 43 Lbs. \$358



AOHT1826 • 42 1/2"W x 17 1/2"D x 39"H • 32 Lbs. \$238



AVJOH • 36"W x 24"D x 25-45"H • 63 Lbs. \$597

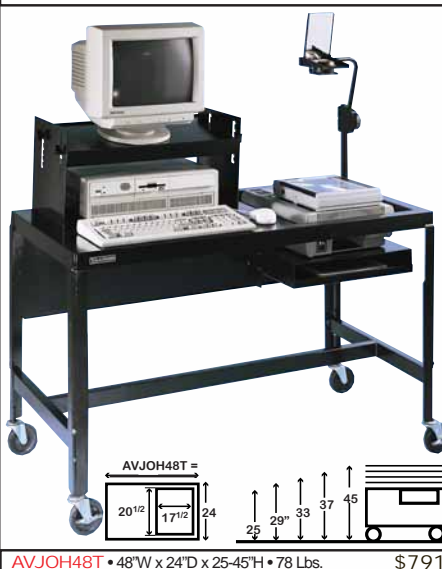

AVJOH48T • 48"W x 24"D x 25-45"H • 78 Lbs. \$791

AVJOH48 • Same w/out terminal platform • 72 Lbs. \$679

Audio/Visual

Endura® Overhead Projector

- Lifetime warranty. Molded shelves and legs won't stain, scratch, dent or rust.
- 3-outlet, 15' surge suppressing electric assembly, UL & CSA listed.
- Retaining lip prevents supplies from sliding off shelves.
- Integral safety push handle.
- Includes set of sure grip pads to keep equipment from sliding.
- Molded cord wrap.
- 4" ball bearing casters, two with locking brake.
- Model OHT50 accommodates the 3M 900 and 9000 series overhead projectors (excluding the 9700 series).
- All models ship UPS.

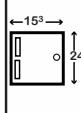

OHT32 • 15 3/4"W x 24"D x 32"H • 31 Lbs. \$312

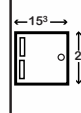

OHS32 • 15 3/4"W x 24"D x 32"H • 32 Lbs. \$332

OHS32 - Same features as OHT32 with middle storage tray shelf for storing transparencies and other supplies. Assembly required. Wt. 32 lbs.

OHT42 - Stand-up table for large overhead projectors. Includes large work area for transparencies and other supplies. Assembly required. Black color only. Wt. 43 lbs.

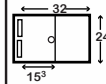

OHT42 • 32"W x 24"D x 36"H • 43 Lbs. \$459

OHT42PS - Same as above with steel pull-out keyboard shelf. Black color only. Wt. 47 lbs.

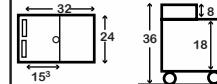

OHT42PS • 32"W x 24"D x 36"H • 47 Lbs. \$481

OHT42PSC - Same as above with locking cabinet. Black color only. Wt. 79 lbs.

OHT42C - Same as OHT42 with locking cabinet. Black color only. Wt. 75 lbs.

OHS42 - Same features as OHT42 with top shelf storage tray shelf for storing transparencies and other supplies. Assembly required. Black color only. Wt. 44 lbs.

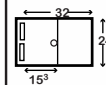

OHT42PSC • 32"W x 24"D x 36"H • 79 Lbs. \$782

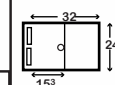

OHS42 • 32"W x 24"D x 36"H • 44 Lbs. \$479

OHT42C • w/out keyboard • 75 Lbs. \$842



Endura® Overhead Projector

- Lifetime warranty. Molded shelves and legs won't stain, scratch, dent or rust.
- 3-outlet, 15' surge suppressing electric assembly, UL & CSA listed.
- Retaining lip prevents supplies from sliding off shelves.
- Integral safety push handle.
- Includes set of sure grip pads to keep equipment from sliding.
- Molded cord wrap.
- 4" ball bearing casters, two with locking brake.
- Model OHT50 accommodates the 3M 900 and 9000 series overhead projectors (excluding the 9700 series).
- All models ship UPS.

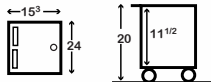

OHT20 • 15 3/4" W x 24" D x 20" H • 23 Lbs. \$284

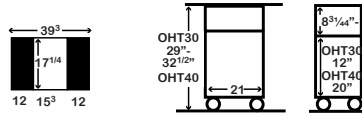

OHT30 • 39 3/4" W x 17 1/4" D x 29" or 32 1/2" H • 29 Lbs. \$397

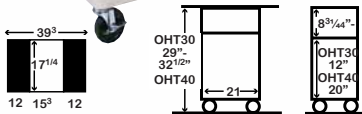

OHT40 • 39 3/4" W x 17 1/4" D x 38" or 40 1/2" H • 30 Lbs. \$437

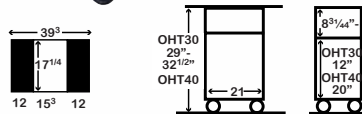

OHT40C • 39 3/4" W x 21" D x 39" H • 56 Lbs. \$716

OHT20 - Compact sit-down overhead projector table. Assembly required. Black color only. Wt. 23 lbs.

OHT30 - Sit-down overhead projector table. Includes two sets of legs to allow top shelf height to match OH projector. Plastic side shelves hold transparencies and other supplies. Assembly required. Specify putty, gray, or black color. Wt. 29 lbs.

OHT40 - Stand-up overhead projector table with same features as above. Specify putty, gray, or black color. Wt. 30 lbs.

OHT40C - Stand-up overhead projector table with cabinet. Includes two sets of legs to allow top shelf height to match OH projector. Plastic side shelves hold transparencies and other supplies. Assembly required. Specify putty, gray, or black color. Wt. 56 lbs.

OHT50 - Stand-up table accommodates the new large overhead projectors and provides a large work area for transparencies and other supplies. Assembly required. Black color only. Wt. 35 lbs.

OHT50C - Same as above with locking cabinet. Black color only. Wt. 57 lbs.

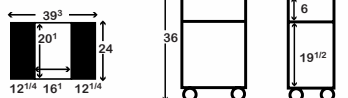

OHT50 • 39 3/4" W x 24" D x 36" H • 35 Lbs. \$445

OHT50C • Same w/locking cabinet • 57 Lbs. \$736

Audio/Visual

Duraweld Tables

- Roll formed shelves with powder coat paint finish.
- Tables are robotically arc welded.
- Cable pass through holes.
- 1/4" retaining lip around each shelf.
- 3-outlet, 15" UL and CSA listed electric assembly with cord plug snap.
- 4" ball bearing casters, two with locking brake.
- AV and AVJ models have safety mats.
- Big wheel models available.
- Cabinet models have reinforced locking doors with full length piano hinges.
- (U) models 13"

AVJ42 models - Adjustable height tables either open shelf or cabinet tables that come with electric assembly. Tables are black, green, red, yellow, or royal blue color except for models AVJ42C and AVJ42BC come in black color only.

AVJ42 - Open shelf table with 4" casters. 41 lbs

AVJ42B - 8" big wheels on one end and LSS safety strap. (U) listed. 48 lbs

AVJ42C - Cabinet table with 4" casters. 55 lbs.

AVJ42BC - Same as above with 8" big wheels on one end and LSS safety strap. (U) listed. 62 lbs

AV26 - Open shelf table w/4" casters & electric assembly. 31 lbs

AV26B - Same as above w/8" big wheels on one end & LSB safety belt. (U) listed. 38 lbs

AV34 - Open shelf table w/4" casters & electric assembly. 41 lbs

AV34B - Same as above with 8" big wheels on one end and LSB safety belt. (U) listed. 47 lbs

AV42 - Open shelf table w/4" casters & electric assembly. 42 lbs.

AV42B - Same as above with 8" big wheels on one end and LSB safety belt. (U) listed. 48 lbs.

ATV56 models - Traditional TV tables with either open shelves or cabinet. Tables are black, green, red, yellow, or royal blue color except for models ATV56C and ATV56BC come in black color only

ATV56 - Adjustable height 24" deep open shelf table. 58 lbs.

ATV56B - Adjustable height 24" deep open shelf table w/8" big wheels on one end. 81 lbs.

ATV56C - Adjustable height 24" deep cabinet table. 89 lbs.

ATV56BC - Adjustable height 24" deep cabinet table w/8" big wheels on one end. 93 lbs

Specify color when ordering AVJ42 or AVJ42B:

AVJ42 = Black AVJ42GN = Green AVJ42RD = Red
AVJ42YW = Yellow AVJ42RB = Royal Blue



Drop leaf shelves available!



AVJ42BC

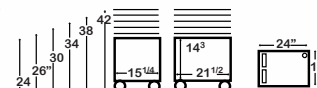

AVJ42 • 24"W x 18"D x 24-42"H • 41 Lbs.	\$353	AVJ42B • w/8" big wheels & safety strap • 48 Lbs.	\$443
AVJ42C • w/locking cabinet • 55 Lbs.	\$527	AVJ42BC • w/cabinet, big wheels & strap • 62 Lbs.	\$616



AV42

AV34B

AV26

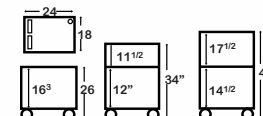

AV26 • 24"W x 18"D x 26"H • 31 Lbs.	\$358	AV26B • w/8" big wheels & safety strap • 38 Lbs.	\$435
AV34 • 24"W x 18"D x 34"H • 41 Lbs.	\$385	AV34B • w/8" big wheels & safety strap • 47 Lbs.	\$462
AV42 • 24"W x 18"D x 42"H • 42 Lbs.	\$399	AV42B • w/8" big wheels & safety strap • 48 Lbs.	\$478

Specify color when ordering AVJ42 or AVJ42B:

AVJ42 = Black AVJ42GN = Green AVJ42RD = Red
AVJ42YW = Yellow AVJ42RB = Royal Blue



ATV56C

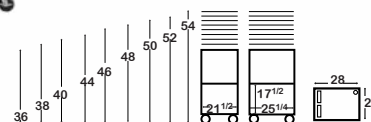

ATV56 • 28"W x 24"D x 36-54"H • 58 Lbs.	\$574	ATV56B • w/8" big wheels • 81 Lbs.	\$679
ATV56C • w/locking cabinet • 89 Lbs.	\$758	ATV56BC • w/cabinet & big wheels • 93 Lbs.	\$872

Audio/Visual

Steel Adjustable Height AV



AVJ42CKD - Adjustable height table with locking cabinet. Features powder coat paint finish, retaining lip around each shelf, and 4" casters, two with locking brake. Height adjusts in 2" increments from 30"-42". 24"W x 18"D x 30"-42"H. Wt. 62 lbs.

AVJ42KD - Same as above without locking cabinet. Wt. 44 lbs.



AVJ42CKD • 24"W x 18"D x 30"-42"H • 62 Lbs. \$508

AVJ42KD • w/out cabinet • 44 Lbs. \$342

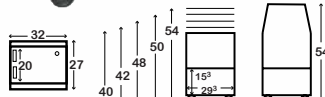

ATW56 • 32"W x 27"D x 40-54"H • 80 Lbs. \$550

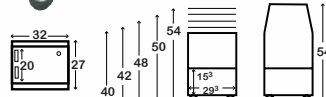

ATW56C • 32"W x 27"D x 40-54"H • 106 Lbs. \$907

ATW56 - Adjustable height wide base table with 4" casters, two with locking brake and electric assembly. Wt. 80 lbs.

ATW56C - Wide base table with cabinet, 4" casters, two with locking brake and electric assembly. Wt. 106 lbs.

ATW48EUL - Adjustable height wide base table with back panel. Includes 4" casters, two fixed two swivel with locking brake, UL and CSA listed electric assembly and LSB safety belt. Wt. 81 lbs.

ATW48CEUL - Adjustable height wide base table with cabinet. Includes 4" casters, two fixed two swivel with locking brake, UL and CSA listed electric assembly and LSB safety belt. Wt. 102 lbs.



Shown with Included
LSB safety belt.

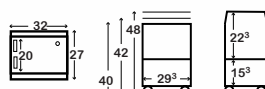

Listed

ATW48EUL • 32"W x 27"D x 40-48"H • 81 Lbs. \$702

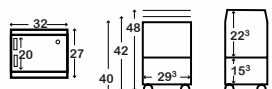

Listed

ATW48CEUL • 32"W x 27"D x 40-48"H • 102 Lbs. \$1010

Audio/Visual

- Wide base for increased stability.
- Roll formed shelves with baked-on powder coat paint finish.
- 1" square tubular steel legs with durable black powder coat paint finish.
- 3-outlet, 15" UL and CSA listed electric assembly.
- 4" ball bearing casters, two with brake.
- Assembly required.
- Lifetime Warranty.
- Ships UPS.

TVW54i - Wide base with electric and 4" casters. 59 lbs.

TVW48i - Wide base with electric and 4" casters. 56 lbs.

TVW44i - Wide base with electric and 4" casters. 58 lbs.

FRTVW4828i - Extra wide base with electric and 8" foam rubber casters. 96 lbs.

TVW54C - Wide base w/locking cabinet, electric, and 4" casters. 93 lbs

TVW48C - Wide base w/ locking cabinet, electric, and 4" casters. 92 lbs

TVW44C - Wide base w/ locking cabinet, electric and 4" casters. 91 lbs

VC - VCR bracket fits all Luxor LTE TV mounts. Adjusts from 14" to 20" wide to accommodate most front loading recorders. VCR rests on 2 3/4" x 6" brackets. Swivels independently of TV mount. All mounting hardware included. Wt. 5 lbs.

LVC - Locking VCR bracket. Adjusts from 14" to 21 1/2" wide to accommodate most DVD/VCR while resting on 2 1/2" x 6" brackets. Swivels independently of TV mount. All mounting hardware included. Wt. 6 lbs.

DVC - Adjustable dual stacking VCR bracket fits all Luxor LTE TV mounts. Adjusts from 14" to 20" wide. VCRs rest on 2 3/4" x 6" brackets. Attaches and swivels independently of TV mount. All mounting hardware included. Wt. 7 lbs.

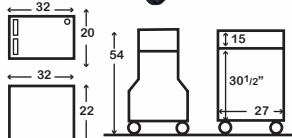

TVW54i • 32"W x 22"D x 54"H • 59 Lbs. \$426

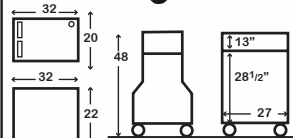

TVW48i • 32"W x 22"D x 48"H • 56 Lbs. \$394

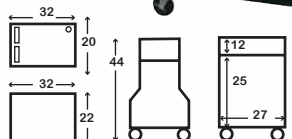

TVW44i • 32"W x 22"D x 44"H • 58 Lbs. \$384

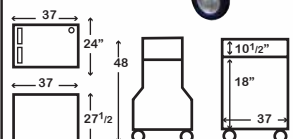

FRTVW4828i • 37"W x 27 1/2"D x 48"H • 96 Lbs. \$979

Shown with optional LSB safety belt.

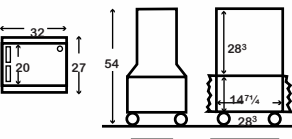

TVW54C • 32"W x 27"D x 54"H • 93 Lbs. \$927

TVW48C • 32"W x 27"D x 48"H • 92 Lbs. \$982

TVW44C • 32"W x 27"D x 44"H • 91 Lbs. \$907

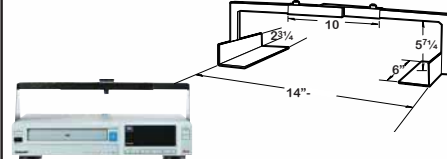

VC • 14"-20"W x 6"H • 5 Lbs. \$90

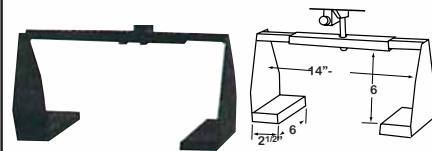

LVC • 14"-21 1/2"W x 6"H • 6 Lbs. \$135

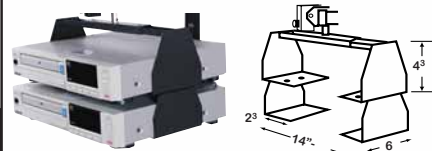

DVC • 14"-20"W x 6"H • 7 Lbs. \$123

All Shown with optional LSB safety belt.



- ### Wide Base Video Tables
- Roll formed shelves with baked-on powder coat paint finish.
 - Integral safety push handle and slots for safety belt.
 - 1" square tubular steel legs with durable black powder coat paint finish.
 - 3-outlet, 15' UL and CSA listed electric assembly.
 - 4" ball bearing casters, two with brake.
 - 1/2" retaining lip and sure grip safety pads prevent equipment from sliding.
 - Cabling hole in top and middle shelves for easy cord pass through.
 - Plug snap keeps plug secured to wrapped cord.
 - Cabinet models have reinforced doors with full piano hinges and set of two keys.
 - Cabinet models with 27"x 32" base patented.
 - Lifetime Warranty.

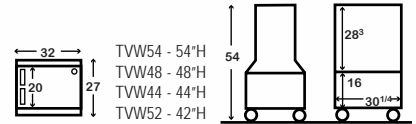

TVW54 • 32"W x 27"D x 54"H • 62 Lbs.	\$529	TVW48 • 32"W x 27"D x 48"H • 61 Lbs.	\$913
TVW44 • 32"W x 27"D x 44"H • 60 Lbs.	\$442	TVW42 • 32"W x 27"D x 42"H • 38 Lbs.	\$428



UL Listed

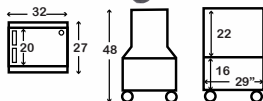

TVW48EUL • 32"W x 27"D x 48"H • 62 Lbs.	\$590
TVW44EUL • 32"W x 27"D x 44"H • 62 Lbs.	\$542



UL Listed

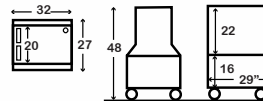

TVW48CEUL • 32"W x 27"D x 48"H • 93 Lbs.	\$897
TVW44CEUL • 32"W x 27"D x 44"H • 93 Lbs.	\$937

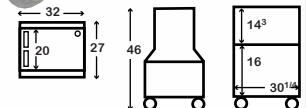

TWP46P • 32"W x 27"D x 46"H • 93 Lbs.	\$979
TWP46 • 32"W x 27"D x 46"H • 91 Lbs.	\$979

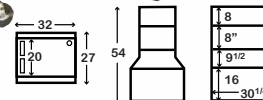

TVW554 • 32"W x 27"D x 54"H • 85 Lbs.	\$643
TVW554C • w/cabinet • 116 Lbs.	\$1037

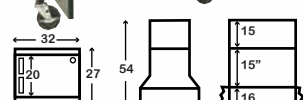

TVWE54C • 32"W x 27"D x 54"H • 106 Lbs.	\$982
---	-------

UL Listed Models

These UL listed models incorporate all the features of other TVW tables in addition to:

- Heavy gauge steel back panel with TVW48EUL.
- LSB model safety belt.

TVW48EUL - UL listed wide base table with electric assembly, 4" casters, 2 fixed, 2 swivel with brake and LSB safety belt. Assembly required.

TVW44EUL - UL listed. Same as above, 44" high.

TVW48CEUL - UL listed wide base cabinet table with electric assembly, 4" casters, 2 fixed, 2 swivel with brake and LSB safety belt. Assembly required.

TVW44CEUL - UL listed. Same as above but 44" high

TVW554 - Wide base with electric and 4" casters.

TVW554C - Same as above with cabinet.

TVWE54C - Wide base with locking cabinet, electric and 4" casters.

TWP46 - UL listed wide base table with electric assembly. Includes 8" semi-pneumatic wheels, 2 fixed, 2 swivel with brake and LSB safety belt. Assembly required.

TWP46P - Wide base table with electric assembly. Includes 8" non-marring pneumatic wheels, 2 fixed, 2 swivel. Non UL. Assembly required.

Audio/Visual

TVS Video Tables

- All models have 20"D x 32"W shelves.
- Roll formed shelves with baked-on powder coat paint finish.
- 1" square tubular steel legs with durable powder coat paint finish.
- Integral safety push handle and slots for safety belt.
- 3-outlet, 15' UL and CSA listed electric assembly.
- 4" casters, two with locking brake. 2" casters standard on some models.
- 1/2" retaining lip and sure grip safety pads prevent equipment from sliding.
- Cabling hole in top and middle shelves for easy cord pass through.
- Plug snap keeps plug secured to wrapped cord.
- Cabinet models have reinforced doors with full piano hinges and set of two keys.
- Assembly required.



TVS44C



TVS48



TVS36

TVS554

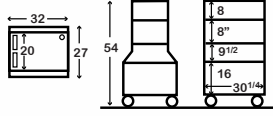

TVS54

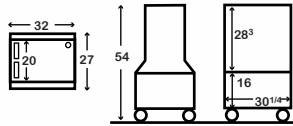

TVS34

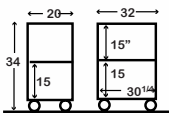

TVS54C

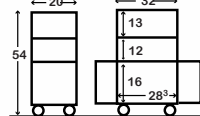

TVS54C

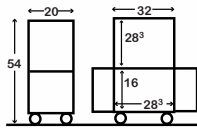

TVS48C

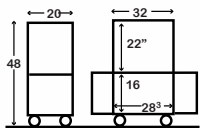

TVS554	• 5 shelf video table	• 32" W x 20"D x 54"H	• 81 Lbs.	• \$588
TVS54	• 3 shelf video table	• 32" W x 20"D x 54"H	• 55 Lbs.	• \$478
TVS48	• 3 shelf video table	• 32" W x 20"D x 48"H	• 54 Lbs.	• \$467
TVS44	• 3 shelf w/2" casters	• 32" W x 20"D x 44"H	• 49 Lbs.	• \$445
TVS34	• 3 shelf w/2" casters	• 32" W x 20"D x 34"H	• 48 Lbs.	• \$436
TVS36	• 2 shelf w/VCR DVD holder	• 32 1/2" W x 21" D x 36" H	• 44 Lbs.	• \$344
Cabinet Models				
TVS54C	• 4 shelf video table	• 32" W x 20"D x 54"H	• 96 Lbs.	• \$957
TVS54C	• 3 shelf video table	• 32" W x 20"D x 54"H	• 83 Lbs.	• \$863
TVS48C	• 3 shelf video table	• 32" W x 20"D x 48"H	• 82 Lbs.	• \$852
TVS44C	• 3 shelf w/2" casters	• 32" W x 20"D x 44"H	• 77 Lbs.	• \$836
TVS34C	• 3 shelf w/2" casters	• 32" W x 20"D x 34"H	• 76 Lbs.	• \$821

TVS44C

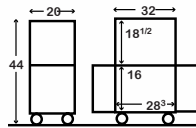

TVS34C

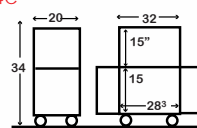

Large Screen Multi-Media Cart

TV40RT - 40" high, pyramid shape, two shelf, large screen multi-media cart with 5" casters, two with locking brake, 3-outlet 15' UL & CSA listed electric assembly, and 2" wide 20' long safety strap with easy lock buckle. Includes 18 1/2" x 17" accessory shelf which mounts under top shelf. Constructed of 7/8" high-density particleboard with resilient vinyl T-moulding. Assembly required. Black color. Wt. 103 lbs.



TV40RT • 42 3/4"W x 24"D x 40"H • 103 Lbs.

\$509



Shown with optional LRS ratchet strap. Order separately.



TVP44LT • 39⁵/₈" W x 27⁵/₈" D x 44" H • 126 Lbs. \$1140

Shown with optional LRS ratchet strap. Order separately.



TVP44SP • 37¹/₄" W x 25¹/₄" D x 44" H • 121 Lbs. \$1111

Large Screen Monitor Tables

- Designed to move heavy equipment easily.
- Heavy gauge steel, arc welded.
- Safety push handle.
- 1 1/2" retaining lip on all shelves.
- 3-outlet, 15' electric assembly, UL and CSA listed.
- 8" non-marring pneumatic tires, 2 fixed, 2 swivel with brake.
- Slots in top shelf for optional safety strap.
- Non-skid safety pads.
- Durable baked-on powder coat paint.
- Lifetime warranty.

TVP44SP - Three shelf table with semi-pneumatic tires. Holds up to 37" TV monitor. 121 lbs.

TVP44 - Three shelf table. Pyramid shape ensures greater stability. 121 lbs.

TVP44C - Same as above with locking cabinet. Holds up to 37" TV monitor. 165 lbs.

TVP44LT - Heavy-duty three shelf table. Holds up to 40" TV monitor. 126 lbs.

TVP44LTC - Same as above with locking cabinet. Holds up to 40" TV monitor. 170 lbs.

TVP32 - Two shelf table. Pyramid shape ensures greater stability. 96 lbs.

TVP32LT - Heavy-duty two shelf large screen monitor table. 101 lbs.



TVP44LTC • 39⁵/₈" W x 27⁵/₈" D x 44" H • 170 Lbs. \$1636



TVP44C • 37¹/₄" W x 25¹/₄" D x 44" H • 165 Lbs. \$1577

TVP44 • w/out cabinet • 121 Lbs. \$1111



Shown with optional LRS ratchet strap. Order separately.

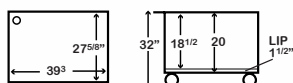

TVP32LT • 39¹/₂" W x 27¹/₂" D x 32" H • 101 Lbs. \$946



Shown with optional LRS ratchet strap. Order separately.

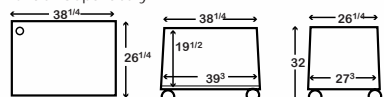

TVP32 • 38¹/₂" W x 26¹/₄" D x 32" H • 96 Lbs. \$944



SP8 Solid rubber high profile semi-pneumatic tires available in place of full pneumatic wheels. Add suffix "SP" to model number. Example: TVP44SP.



FR8 heavy duty 8" foam rubber casters. Add suffix "FR" to model number.

Audio/Visual

Universal Table Accessories

Equipment Holder

MTO Supply and equipment holder. Holds pens, screwdrivers etc... between tension mounted loops. Includes 12 hooks that mount to loops. 2 lbs.\$22



SAFETY BELT

LRS2 15' long, 1" wide ratcheting safety strap with "J" hooks. 2 lbs. \$55



SAFETY BELT

LHB 10 feet long, 2 inches wide safety belt. Wt. 1 lbs.\$64



SAFETY BELT

LSB 8 feet long, 1 inch wide strap with "J" hooks and easy lock buckle. Wt. 1 lbs.\$50



RATCHET STRAP

LRS 12 feet long, 1 inch wide strap with ratcheting buckle. Wt. 1 lbs.\$61



SAFETY STRAP

LSS 10 feet long, 1 inch wide safety strap with easy-lock buckle. Wt. 1 lbs.\$27
LSS2 Same as above, 10 feet long, 2 inches wide.\$34



ELECTRONIC SECURITY SYSTEM

LSA Alarm lock with 6-foot cable. Provides extra security by emitting an ear piercing alarm when tampered with. Wt. 2 lbs. \$92
LSAK Same as above but keyed alike. Wt. 2 lbs.\$92
LSAP Optional - two additional mounting plates. 1 lb. \$26



SECURITY SYSTEM

LSK 6' cable, two mounting plates and lock. Wt. 2 lbs.\$53
LSO Optional - two additional mounting plates. Wt. 1 lbs.\$24
LCK 3-foot cable, two mounting plates and lock. Wt. 3 lbs.\$46



ELECTRICAL CORD WRAP

SW Plastic cord wrap for small plastic carts. Wt. 1 lb.\$14
LW Plastic cord wrap for large plastic carts. Wt. 1 lb.\$21



WIRE CD HOLDER

LCDWR Wire CD holder, holds 24 CD's. Wall mount or desktop application. Chrome color. 5 1/2"W x 15"H x 5 1/4"D. Wt. 2 lbs.\$10



DUAL WHEEL CASTERS

DW 4" dual wheel casters. Wt. 10 lbs.\$64
In lieu of standard casters add suffix "DW"\$26



5" CASTERS

C5 Heavy duty 5" ball bearing casters, two with locking brake. Wt. 5 lbs.\$68
In lieu of standard casters add suffix "C5"\$37



BIG WHEEL ASSEMBLY

LBW Two 8" big wheel rolling ball bearing, hard rubber wheels. Wt. 11 lbs.\$96

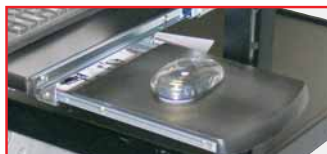

SLIDE OUT MOUSE SHELF

EMS Mounts to existing pull-out keyboard shelf on Luxor's Endura workstations. Minor modifications required for installation on tables purchased prior to 1997. Wt. 8 lbs.\$64



SIDE SHELF

LES 12"W x 18"D. Fits on the side of 18"D plastic workstations. Wt. 7 lbs.\$43



SUPPLY BASKETS

T5 For use with, 24" wide Endura models and LEW units. Wt. 5 lbs.\$52

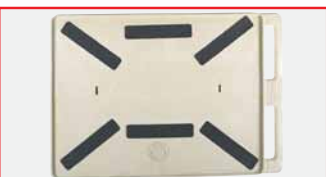

SAFETY STRIPS

LSGS Set of six 2" x 10" adhesive strips with sure grip surface. Keeps equipment from sliding. Wt. 1 lbs.\$51

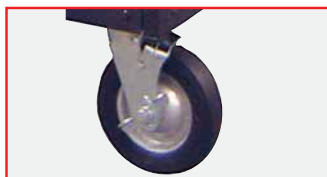

FOAM RUBBER CASTERS

FR8 FR8 heavy duty 8" foam rubber casters. Add suffix "FR" to model number. Wt. 29 lbs.\$169



VCR COMPARTMENT

TRVC Enclose your video equipment for security. Fits all LE Endura models. Wt. 7 lbs.\$44



RECOIL POWER ASSEMBLY

RE20 Two-outlet, 20' heavy duty cord, UL listed. Extends and locks. Wt. 4 lbs.\$115



ELECTRIC ASSEMBLY

ESE Optional 6-outlet, 15' surge suppressing electric assembly with reset. Wt. 4 lbs.\$83



ELECTRIC

LEES 3-outlet surge suppressing power cord and cord wrap bracket. Wt. 3 lbs.\$90

Audio/Visual

Endura® Video/equipment Tables

- Top shelf reinforced with one aluminum bar.
- Integral safety push handle is molded into top shelf for a sturdy sure grip.
- Recessed door handle on locking cabinet models.
- Full piano door hinge for maximum strength on cabinet models.
- Big wheel models are UL listed.
- Lifetime warranty. Molded plastic shelves and legs won't stain, scratch, dent or rust.
- 1/4" retaining lip and sure grip safety pads prevent equipment from sliding.
- "Cable track" cord management system keeps cords neatly secured and free of entanglements.
- Cabling hole in top shelf with cord guide cover.
- 4" ball bearing casters, two with locking brake.
- 3 outlet, 15' surge suppressing electric assembly, UL and CSA listed.
- Electric assembly in handle, cabinet and big wheel designs are patented.



LE26C

LE26

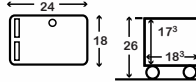

LE26 • 24"W x 18"D x 26"H • 23 Lbs.	\$274
LEB26 • with 8" big wheels • 33 Lbs.	\$351
LE26C • with locking cabinet • 46 Lbs.	\$550
LEB26C • with big wheels & cabinet • 55 Lbs.	\$607



LE34

LEB34C

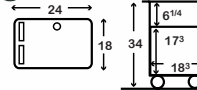

LE34 • 24"W x 18"D x 34"H • 30 Lbs.	\$631
LEB34 • with 8" big wheels • 35 Lbs.	\$403
LE34C • with locking cabinet • 53 Lbs.	\$610
LEB34C • with big wheels & cabinet • 58 Lbs.	\$694



LE42WC

Walnut cabinet available for any unit. Add "WC"

LE42

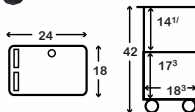

LE42 • 24"W x 18"D x 42"H • 32 Lbs.	\$334
LEB42 • with 8" big wheels • 37 Lbs.	\$412
LE42C • with locking cabinet • 55 Lbs.	\$616
LEB42C • with big wheels & cabinet • 60 Lbs.	\$708



3-outlet, 15' surge suppressing electric assembly, UL and CSA listed. Molded cord wrap attaches around table leg and swings out for easy access.



18" Deep x 24" Wide top shelf reinforced with single aluminum bar.

Available in black, gray and putty with walnut or gray cabinet. For walnut add "WC" to model number
Ex: LE26WC



Multi-Height Endura® Tables

Height adjusts from 16" - 42"

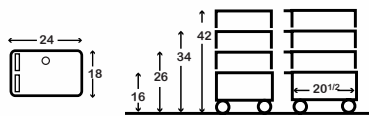

LEDUO • 24"W x 18"D x 16-42"H • Multi-height open shelf table with 3-outlet surge electric • 28 lbs.	\$341
LEBDUO • 24"W x 18"D x 16-42"H • Same as above with 8" big wheels • 38 lbs.	\$423
LEDUOC • 24"W x 18"D x 16-42"H • Multi-height with locking cabinet & surge electric • 51 lbs.	\$628
LEBDUOC • 24"W x 18"D x 16-42"H • Same as above with 8" big wheels • 60 lbs.	\$681



LE26 - Open shelf table with surge electric. Wt. 23 lbs.

LEB26 - (UL) listed. Open shelf table with surge electric, 8" big wheels on one end and LSS safety strap. Wt. 33 lbs.

LE26C - Locking cabinet table with surge electric. Wt. 46 lbs.

LEB26C - (UL) listed. Locking cabinet table with surge electric, 8" big wheels on one end and LSS safety strap. Wt. 55 lbs.

LE34 - Open shelf table with surge electric. Wt. 30 lbs.

LEB34 - (UL) listed. Open shelf table with surge electric, 8" big wheels on one end and LSS safety strap. Wt. 35 lbs.

LE34C - Locking cabinet table with surge electric. Wt. 53 lbs.

LEB34C - (UL) listed. Locking cabinet table with surge electric, 8" big wheels on one end and LSS safety strap. Wt. 58 lbs.

LE42 - Open shelf table with surge electric. Wt. 32 lbs.

LEB42 - (UL) listed. Open shelf table with surge electric, 8" big wheels on one end and LSS safety strap. Wt. 37 lbs.

LE42C - Locking cabinet table with surge electric. Wt. 55 lbs.

LEB42C - (UL) listed. Locking cabinet table with surge electric, 8" big wheels on one end and LSS safety strap. Wt. 60 lbs.

Audio/Visual

Endura® Video Tables

- Top shelf reinforced with two aluminum bars.
- Integral safety push handle is molded into top shelf for a sturdy sure grip.
- Recessed door handle on cabinet models.
- Full piano door hinge for maximum strength on cabinet models.
- Locking cabinet includes set of two keys.
- Electric assembly in handle, cabinet and big wheel designs are patented.
- 8" big wheel models available.
- Lifetime warranty. Molded plastic shelves and legs won't stain, scratch, dent or rust.
- 1/2" retaining lip and self adhesive safety strips prevent equipment from sliding.
- "Cable track" cord management system keeps cords neatly secured and free of entanglements.
- Cabling hole in top shelf with cord guide cover.
- 4" ball bearing casters, two with locking brake.

LE27 - Open shelf table with surge electric. Wt. 43 lbs.

LEB27 - Open shelf table with surge electric, 8" big wheels on one end. Wt. 48 lbs.

LE27C - Locking cabinet table with surge electric. Wt. 74 lbs.

LEB27C - Locking cabinet table with surge electric, 8" big wheels on one end. Wt. 84 lbs.

LE40 - Open shelf table with surge electric. Wt. 52 lbs.

LEB40 - Open shelf table with surge electric, 8" big wheels on one end. Wt. 60 lbs.

LE40C - Locking cabinet table with surge electric. Wt. 84 lbs.

LEB40C - Locking cabinet table with surge electric, 8" big wheels on one end. Wt. 90 lbs.

LE48 - Open shelf table with surge electric. Wt. 53 lbs.

LEB48 - Same as above with 8" big wheels on one end. Wt. 60 lbs.

LE48C - Locking cabinet table with surge electric. Wt. 85 lbs.

LEB48C - Same as above with 8" big wheels on one end. Wt. 92 lbs.

LE54 - Open shelf table with surge electric. Wt. 54 lbs.

LEB54 - Open shelf table with surge electric, 8" big wheels on one end. Wt. 62 lbs.

LE54C - Locking cabinet table with surge electric. Wt. 86 lbs.

LEB54C - Locking cabinet table with surge electric, 8" big wheels on one end. Wt. 93 lbs.



LE27C

LEB27

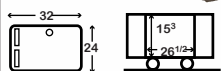

LE27 • 32"W x 24"D x 27"H • 43 Lbs. \$447

LEB27 • with 8" big wheels • 48 Lbs. \$532

LE27C • with locking cabinet • 74 Lbs. \$845

LEB27C • with big wheels & cabinet • 84 Lbs. \$940



LEB40C

LE40

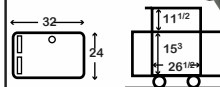

LE40 • 32"W x 24"D x 40"H • 52 Lbs. \$532

LEB40 • with 8" big wheels • 60 Lbs. \$629

LE40C • with locking cabinet • 84 Lbs. \$940

LEB40C • with big wheels & cabinet • 90 Lbs. \$1029



LE48

LEB48C

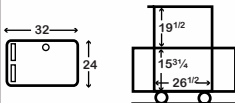

LE48 • 32"W x 24"D x 48"H • 53 Lbs. \$550

LEB48 • with 8" big wheels • 60 Lbs. \$636

LE48C • with locking cabinet • 85 Lbs. \$958

LEB48C • with big wheels & cabinet • 92 Lbs. \$1050



LEB54C

LE54

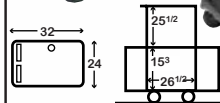

LE54 • 32"W x 24"D x 54"H • 54 Lbs. \$563

LEB54 • with 8" big wheels • 62 Lbs. \$648

LE54C • with locking cabinet • 86 Lbs. \$975

LEB54C • with big wheels & cabinet • 93 Lbs. \$1062



Multi-Height Endura® Tables

Height adjusts from 27" - 54"

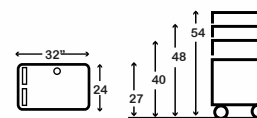

LELDUO • 32"W x 24"D x 27-54"H • Multi-height open shelf table with 3-outlet surge electric • 56 lbs. \$591

LELBDUO • 32"W x 24"D x 27-54"H • Same as above with 8" big wheels • 65 lbs. \$674

LELDUOC • 32"W x 24"D x 27-54"H • Multi-height with locking cabinet & surge electric • 88 lbs. \$1005

LELBDUOC • 32"W x 24"D x 27-54"H • Same as above with 8" big wheels • 97 lbs. \$1096



Endura® Video Tables



Large 42" wide top shelf available for any 32" W x 24" D LE unit (except two shelf units with cabinet).

Add "WT" to model number.
Example- **LEB54WT**



LE40WT • 42"W x 24"D x 40"H • 55 Lbs.	\$562
LE48WT • 42"W x 24"D x 48"H • 56 Lbs.	\$580
LE54WT • 42"W x 24"D x 54"H • 57 Lbs.	\$592

WT • 42"W x 24"D • Add \$32 to cost of large LE unit.



32" x 24" LE models top shelf reinforced with two aluminum bars.

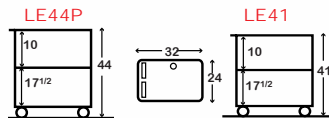

LE44P • 32"W x 24"D x 44"H • 76 Lbs.	\$886
LE41 • Same w/5" plate casters • 41"H • 60 Lbs.	\$785

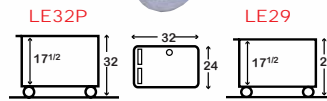

LE32P • 32"W x 24"D x 32"H • 66 Lbs.	\$798
LE29 • Same w/5" plate casters • 29"H • 49 Lbs.	\$700



FR8 heavy duty 8" foam rubber casters. Add suffix "FR" to model number.



Heavy duty solid core 5" plate casters available in lieu of pneumatic tires. See models LE29 and LE41.



SP8 Solid rubber high profile semi-pneumatic tires are available in place of full pneumatic wheels. Add suffix "SP" to model number.
Example LE44SP.

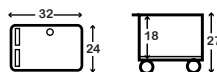

LPT27 • 32"W x 24"D x 27"H • 39 Lbs.	\$330
---	-------

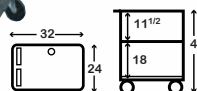

LPT48 • 32"W x 24"D x 48"H • 55 Lbs.	\$460
LPT40 • Same as above 40"H • 54 Lbs.	\$445
LPT54 • Same as above 54"H • 56 Lbs.	\$437

LPT27 - Two shelf table with lower tray, 4" casters, two with brake. 27" high. Wt. 39 lbs.

LPT40 - 40" high three shelf table with same features as above. Wt. 54 lbs.

LPT48 - 48" high table with same features as above. Wt. 55 lbs.

LPT54 - 54" high table with same features as above. Wt. 56 lbs.

LPTBW - Optional big wheel assembly. Wt. 11 lbs.

LPE - Optional electric assembly, UL approved. Wt. 3 lbs.

Audio/Visual

Endura® Editing/Production Centers

Production Centers Feature:

- Fluid pan head mono pod camera mount.
- Molded plastic shelves and legs won't stain, scratch, dent or rust.
- Integral push-pull handle.
- Cord management system.
- 3-outlet, 15' surge suppressing electric assembly, UL and CSA listed.
- Reinforced doors and cabinet panels are heavy gauge steel with baked-on powder coat paint finish.
- Doors on cabinet models have full piano hinges, two point locking system and set of two keys.
- Mono pod mount adjusts from 34" - 56" from middle shelf.
- 8" big wheels

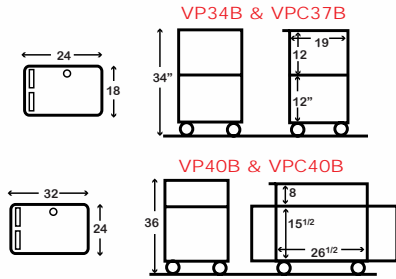

Editing Centers Feature:

- Lifetime warranty. Molded plastic shelves and legs won't stain, scratch, dent or rust.
- Integral safety push handle is molded into top shelf for a sturdy sure grip.
- Top shelf reinforced with two aluminum bars except LE33 and LEB33
- Comes with 3 outlet, 15' surge suppressing electric assembly, UL and CSA listed.
- 4" casters, two with locking brake.
- 1/2" retaining lip and self adhesive safety strips prevent equipment from sliding.
- Cabling hole in top shelf with cord guide cover.

LEVC Carts Feature:

- Top shelf reinforced with one aluminum bar on models LEVC34 and LEVC42.
- Top shelf reinforced with two aluminum bars on model LEVC45.
- Integral safety push handle is molded into top shelf for a sturdy sure grip.
- Lifetime warranty. Molded plastic shelves and legs won't stain, scratch, dent or rust.
- 4" ball bearing casters, two with locking brake.
- Assembly required.
- TRVC is also sold separately. Fits all LE Endura models.
- Complete with 3 outlet, 15' surge suppressing electric assembly, UL and CSA listed.

LEVC42 - 42" two-shelf Endura® equipment table with tamper-resistant video compartment. Complete with 3-outlet, 15' surge suppressing electric assembly, UL and CSA listed, 4" casters, two with locking brake. 24"W x 18"D x 42"H. Wt. 29 lbs.

LEVC34 - Same features as above 34"H.

LEVC45 - Same features as above 32"W x 24"D x 35 1/2"H.

Endura® Professional Production Centers



Cameras Not Included.

VPC37B • 24"W x 18"D x 34"H • Open shelf production center • 43 Lbs.	\$670
VPC40B • 24"W x 18"D x 36"H • Production center with cabinet • 66 Lbs.	\$926
VPC37B • 24"W x 18"D x 34"H • Production center with cabinet • 66 Lbs.	\$926
VPC40B • 24"W x 18"D x 36"H • Production center with cabinet • 25 Lbs.	\$1278

Endura® Editing Centers

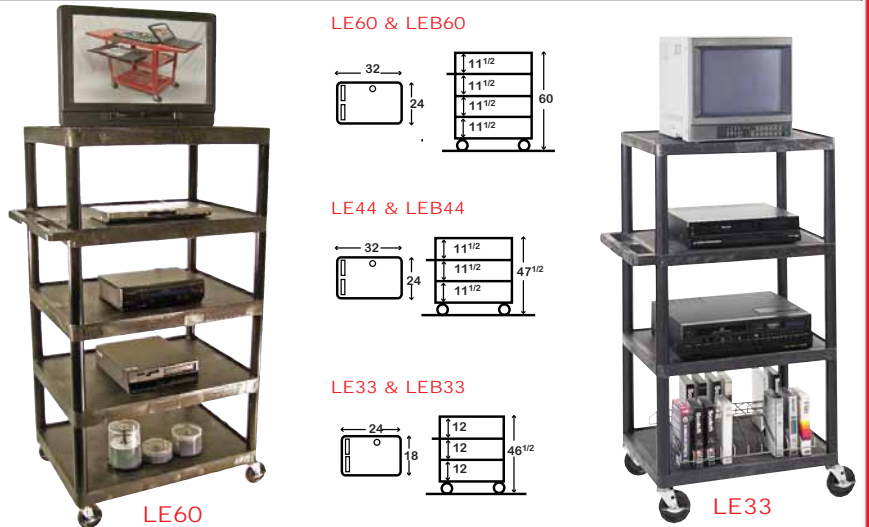

LE60 • 32"W x 24"D x 60"H • 5 Shelf editing center • 81 Lbs.	\$742
LEB60 • 32"W x 24"D x 60"H • 5 Shelf editing center w/8" big wheels • 81 Lbs.	\$866
LE44 • 32"W x 24"D x 47 1/2"H • 4 Shelf editing center • 52 Lbs.	\$653
LEB44 • 32"W x 24"D x 47 1/2"H • 4 Shelf editing center w/8" big wheels • 74 Lbs.	\$734
LE33 • 24"W x 18"D x 46 1/2"H • 4 Shelf editing center • 36 Lbs.	\$362
LEB33 • 24"W x 18"D x 46 1/2"H • 4 Shelf editing center w/big wheels • 41 Lbs.	\$447

LEVC42 • 24"W x 18"D x 42"H • 29 Lbs.	\$347	LEVC45 • 32"W x 24"D x 35 1/2"H • 47 Lbs.	\$500
LEVC34 • 24"W x 18"D x 34"H • 27 Lbs.	\$337		

Audio/Visual

Endura® Video Consoles

- 3-outlet, 15' surge suppressing electric assembly, UL and CSA listed.
- Convenient cord wrap on back panel. Plug snap keeps plug secured to wrapped cord.
- Recessed door handles.
- Ventilation louvers in back panels.
- 4" casters, two with locking brake.
- Integral safety push handle is molded into shelf.
- Retaining lip on top shelf.
- Cabinet doors and panels are heavy gauge steel with baked-on powder coat paint finish. Cabinet design is patented.
- Reinforced locking doors have full piano hinges. Includes set of 2 keys.
- Provisions for cable pass through between shelves and cable hole in top shelf.



LE56LC • 32"W x 24"D x 55"H • 159 Lbs. \$849



LEF40C • 32"W x 24"D x 44 1/2"H • 111 Lbs. \$796



LEF56C • 32"W x 24"D x 59 1/2"H • 159 Lbs. \$960



LEB65C • 32"W x 24"D x 59 1/2"H • 161 Lbs. \$899

LE65C • w/out 8" big wheels • 134 Lbs. \$749



LEF42C • 24"W x 18"D x 42"H • 77 Lbs. \$660

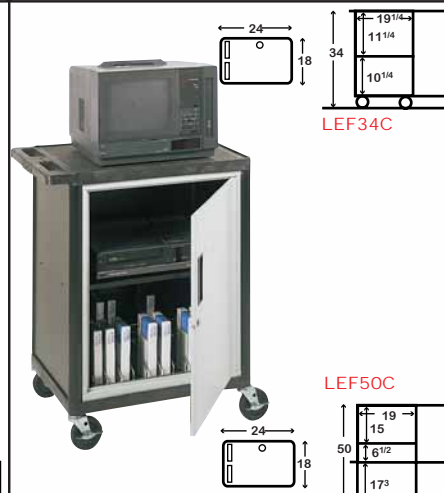

LEF34C • 24"W x 18"D x 34"H • 66 Lbs. \$532

LE50C • 24"W x 18"D x 50"H • 68 Lbs. \$608

LEB50C • 24"W x 18"D x 50"H • 73 Lbs. \$689

LE56LC - 55" high partially enclosed lower locking video console with 4" casters, two with locking brake and 3-outlet, 15' surge suppressing electric assembly, UL and CSA listed. Wt. 159 lbs.

LEF40C - 44" high locking video console with 4" casters, two with locking brake, 3-outlet, 15' surge suppressing electric assembly, UL and CSA listed, and one shelf. Wt. 111 lbs. Shown with optional LECS metal shelf. Order separately. Wt. 18 lbs.

LEF56C - 59" high locking video console with 4" casters, two with locking brake and 3-outlet, 15' surge suppressing electric assembly, UL and CSA listed. Wt. 159 lbs.

LE65C - 65" high partially enclosed locking video console with 4" casters, two with locking brake and 3-outlet, 15' surge suppressing electric assembly, UL and CSA listed. Wt. 134 lbs.

LEB65C - Same as above with 8" big wheels on one end. Wt. 161 lbs.

LEF42C - 42" high locking video console with 4" casters, two with locking brake and 3-outlet, 15' surge suppressing electric assembly, UL and CSA listed. Wt. 77 lbs.

LEF34C - 34" high locking video console with 4" casters, two with locking brake and 3-outlet, 15' surge suppressing electric assembly, UL and CSA listed. Wt. 66 lbs.

LE50C - 50" high partially enclosed locking video console with 4" casters, two with locking brake and 3-outlet, 15' surge suppressing electric assembly, UL and CSA listed. Assembly required. Wt. 68 lbs.

LEB50C - Same as above with 8" big wheels on one end. Wt. 73 lbs.

Low Priced Plastic Tables

24"W x 18"D shelves

- Lifetime warranty. Molded plastic shelves and legs won't stain, scratch, dent or rust.
- Electric in handle and big wheel design are patented.
- Cabling hole in top shelf for cord management.
- Integral safety push handle and cord wrap.
- Retaining lip around each shelf.
- Optional 3-outlet, 15' UL listed power cord mounts in handle.
- 4" ball bearing casters, two with locking brake.
- Heavy duty 8" big wheel models available.
- Assembly required.

LP26 Series



LP26	• 26" H • Open shelf table • 20 Lbs.	\$183
LP26E	• 26" H • With electric • 21 Lbs.	\$243
LP26BW	• 26" H • With 8" big wheels • 29 Lbs.	\$270
LP26EBW	• 26" H • Electric and 8" big wheels • 25 Lbs.	\$323
LP26C	• 26" H • With locking cabinet • 43 Lbs.	\$478
LP26CE	• 26" H • With cabinet and electric • 44 Lbs.	\$538
LP26CBW	• 26" H • With cabinet and 8" big wheels • 52 Lbs.	\$568
LP26CEBW	• 26" H • Electric, cabinet, 8" big wheels • 48 Lbs.	\$629

LP34 Series



LP34	• 34" H • Open shelf table • 24 Lbs.	\$197
LP34E	• 34" H • With electric • 25 Lbs.	\$258
LP34BW	• 34" H • With 8" big wheels • 28 Lbs.	\$285
LP34EBW	• 34" H • Electric and 8" big wheels • 30 Lbs.	\$340
LP34C	• 34" H • With locking cabinet • 49 Lbs.	\$472
LP34CE	• 34" H • With cabinet and electric • 49 Lbs.	\$530
LP34CBW	• 34" H • With cabinet and 8" big wheels • 51 Lbs.	\$559
LP34CEBW	• 34" H • Electric, cabinet, 8" big wheels • 61 Lbs.	\$616

LP42 Series

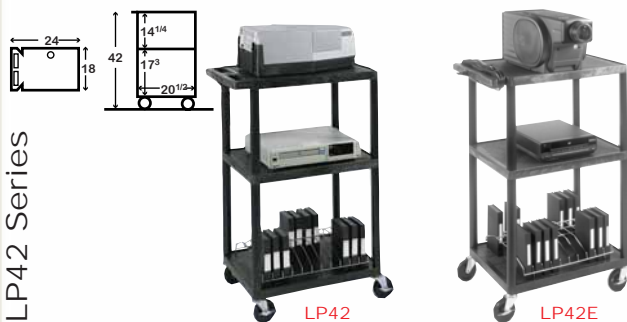

LP42	• 42" H • Open shelf table • 24 Lbs.	\$207
LP42E	• 42" H • With electric • 27 Lbs.	\$264
LP42BW	• 42" H • With 8" big wheels • 31 Lbs.	\$291
LP42EBW	• 42" H • Electric and 8" big wheels • 31 Lbs.	\$348
LP42C	• 42" H • With locking cabinet • 47 Lbs.	\$480
LP42CE	• 42" H • With cabinet and electric • 49 Lbs.	\$539
LP42CBW	• 42" H • With cabinet and 8" big wheels • 54 Lbs.	\$568
LP42CEBW	• 42" H • Electric, cabinet, 8" big wheels • 64 Lbs.	\$627

Multi-Height Series
24" W x 18" D & 24" W x 32" D

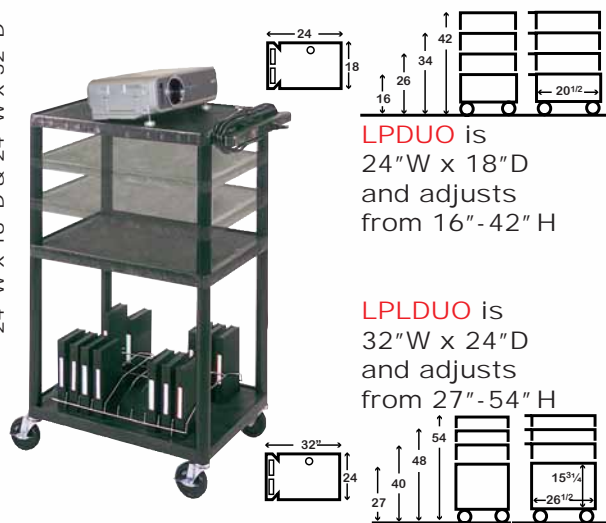

LPDUO is 24"W x 18"D and adjusts from 16" - 42" H

LPLDUO is 32"W x 24"D and adjusts from 27" - 54" H

LPDUO	• Multi-height table • 25 Lbs.	\$227
LPDUOE	• With electric • 26 Lbs.	\$287
LPDUOBW	• With 8" big wheels • 32 Lbs.	\$314
LPDUOEBW	• With electric and 8" big wheels • 32 Lbs.	\$369
LPDUOC	• With locking cabinet • 48 Lbs.	\$503
LPDUOCE	• With cabinet and electric • 49 Lbs.	\$562
LPDUOCBW	• With cabinet and 8" big wheels • 55 Lbs.	\$586
LPDUOCEBW	• With cabinet, electric & big wheels • 55 Lbs.	\$648
LPLDUO	• Large multi-height table • 52 Lbs.	\$486
LPLDUOE	• With electric • 54 Lbs.	\$551
LPLDUOBW	• With 8" big wheels • 60 Lbs.	\$578
LPLDUOEBW	• With electric and 8" big wheels • 62 Lbs.	\$633

EMCPU - CPU tower holder fits most plastic carts.



32" W x 24" D shelves

Low Priced Plastic Tables

- Lifetime warranty. Molded plastic shelves and legs won't stain, scratch, dent or rust.
- Electric in handle and big wheel design are patented.
- Cabling hole in top shelf for cord management.

- Integral safety push handle and cord wrap.
- Retaining lip around each shelf.
- Optional 3-outlet, 15' UL listed power cord mounts in handle.

- 4" ball bearing casters, two with locking brake.
- Heavy duty 8" big wheel models available.
- Assembly required.

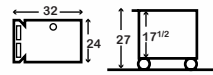

LP27 Series



LP27E

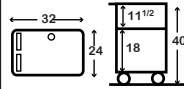

LP40 Series



LP40

LP27 • 27" H • Open shelf table • 36 Lbs.	\$330	LP40 • 40" H • Open shelf table • 44 Lbs.	\$426
LP27E • 27" H • With electric • 36 Lbs.	\$417	LP40E • 40" H • With electric • 46 Lbs.	\$490
LP27BW • 27" H • With 8" big wheels • 41 Lbs.	\$417	LP40BW • 40" H • With 8" big wheels • 54 Lbs.	\$516
LP27EBW • 27" H • Electric and 8" big wheels • 41 Lbs.	\$474	LP40EBW • 40" H • Electric and 8" big wheels • 55 Lbs.	\$572
LP27C • 27" H • With locking cabinet • 68 Lbs.	\$704	LP40C • 40" H • With locking cabinet • 77 Lbs.	\$808
LP27CE • 27" H • With locking cabinet and electric • 70 Lbs.	\$762	LP40CE • 40" H • With cabinet and electric • 78 Lbs.	\$894
LP27CEBW • 27" H • Electric, cabinet, 8" big wheels • 68 Lbs.	\$848	LP40CEBW • 40" H • Electric, cabinet, 8" big wheels • 84 Lbs.	\$953

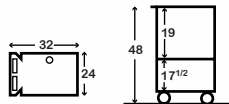

LP48 Series



LP48C

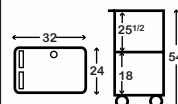

LP54 Series



LP54

LP48 • 48" H • Open shelf table • 47 Lbs.	\$444	LP54 • 54" H • Open shelf table • 48 Lbs.	\$456
LP48E • 48" H • With electric • 48 Lbs.	\$508	LP54E • 54" H • With electric • 49 Lbs.	\$519
LP48BW • 48" H • With 8" big wheels • 55 Lbs.	\$535	LP54BW • 54" H • With 8" big wheels • 56 Lbs.	\$547
LP48EBW • 48" H • Electric and 8" big wheels • 55 Lbs.	\$591	LP54EBW • 54" H • Electric and 8" big wheels • 60 Lbs.	\$602
LP48C • 48" H • With locking cabinet • 79 Lbs.	\$827	LP54C • 54" H • With locking cabinet • 80 Lbs.	\$840



L220 - Adjustable magnetic whiteboard with an aluminum frame. Easy flip locks allow you to adjust the unit from 31"H - 47"H. Can be used as a tabletop or 31" free standing floor unit. Comes complete with a handle for easy transport. The whiteboard is bright white porcelain over metal and measures 16"W x 22"H x 1"D. The aluminum frame measures 21"W x 31 - 47"H x 21"D. Assembly required. Wt. 11 lbs.

L240 - Adjustable magnetic whiteboard with an aluminum frame. Easy knob adjustment allows you to adjust the unit from 40"H - 57"H. Can be used as a tabletop or free standing floor unit. Comes complete with a handle for easy transport and a 2" tray for marker and eraser storage. The whiteboard is bright white porcelain over metal and measures 26"W x 36"H x 1"D. The aluminum frame measures 27"W x 40 - 57"H x 29"D. Assembly required. Wt. 22 lbs.

L270 - Double sided magnetic whiteboard with an aluminum frame. Knob adjustment locks the whiteboard into place once you have it at the required position. Comes complete with 2" casters, two with locking brake. The whiteboard measures 22"W x 34"H x 1"D. The aluminum frame measures 32"W x 57"H x 27"D. Assembly required.

L340 - Large double sided magnetic whiteboard with a heavy duty aluminum frame. The reversing mechanism is designed to make flipping to the other side a cinch. Easy adjusting knob locks the whiteboard into place once you have it at the required position. Comes complete with 2" casters, two with locking brake. The whiteboard measures 46"W x 34"H x 1"D. The aluminum frame measures 47"W x 73"H x 24"D. Assembly required. Wt. 38 lbs.



L220 • 21"W x 21"D x 31-47"H • 11 Lbs. \$308



L240 • 27"W x 29"D x 40-57"H • 22 Lbs. \$370



L270 • 32"W x 27"D x 57"H • 30 Lbs. \$258



L340 • 47"W x 24"D x 73"H • 38 Lbs. \$575

Audio/Visual

Economy Easels



L250 • Aluminum Easel • 68"H • 7 Lbs. \$302



L200 • Aluminum Easel • 68"H • 5 Lbs. \$214

L250 - Portable aluminum lecturer's easel with fold out adjustable chart holder and quick release easel pad clamps. Push button leg release allows for easy height adjustment and compact storage size. 68"H. Wt. 7 lbs.

L200 - Portable aluminum poster easel with fold out adjustable chart holder. Leg release allows for easy height adjustment and compact storage size. 68"H. Wt. 5 lbs.

C200 - Water repellent nylon carrying case will accommodate models L200 and L250. Wt. 3 lbs.

C300 - Water repellent nylon carrying case will accommodate model L300. 43" x 31" x 2". Wt. 4 lbs.



C200

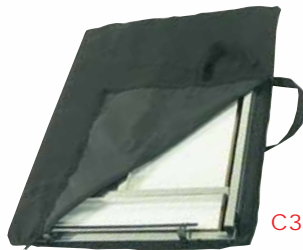

C300



L300 - Lecturer's pad/presentation easel, features aluminum tubular frame, a white board surface which can be used with dry erase markers or for a slide presentation. Includes 24" marker tray and will accommodate easel pad. Push button leg release allows for easy height adjustment and compact storage size. Floor or table top application. 72"H. Wt. 14 lbs.

P504P - Package of 3 plain easel pads, 50 sheets each. 21"W x 30"H. Wt. 22 lbs.

L100 - Hardwood poster easel constructed of solid mahogany with a satin finish. Light wt. yet sturdy. 65"H. Assembly required. Wt. 5 lbs.

L150 - Heavy duty hardwood poster easel. Solid mahogany A-frame construction with a satin finish. Adjustable chart holder. Folds flat for storage. 63"H. Assembly required. Wt. 15 lbs.

C200 • Carry Case for L200 & L250 • 3 Lbs. \$72

L300 • Whiteboard Easel • 72"H • 14 Lbs. \$431

C300 • Carry Case for L300 • 4 Lbs. \$72

P504P • 3 Easel Pads • 21"W x 30"H • 22 Lbs. \$100



L100 • Hardwood Easel • 65"H • 5 Lbs. \$56



L150 • Hardwood Easel • 63"H • 15 Lbs. \$152



Audio/Visual

Lecterns/Wood Laminate

LX9128 - Adjustable height lectern complete with 2" casters, 2 with brake. Plastic knob on adjusting mechanism allows for height adjustments. Top with retainer lip tilts to allow for flat work surface. Constructed of heavy-duty laminate with steel frame. Minimal assembly required. Red Oak with black frame. Wt. 23 lbs.

LX50 - All steel electrically welded lectern with black finish. Tilts back on rear wheels for easy mobility. Ships assembled. Wt. 43 lbs.

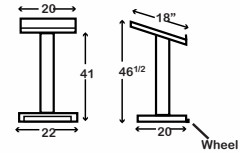
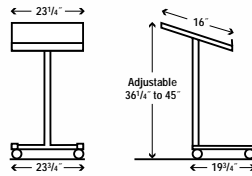

LX9128 • 23 1/4" W x 19 1/4" D x 36 1/4"-45" H • 23 Lbs. \$186

LX50 • 20" W x 20" D x 46 1/2" H • 43 Lbs. \$246

LD Series

- Available in light executive gray color.
- Pockets made from durable, injection molded plastic, mounted on tubular steel frames.
- Standard pocket size of 12⁵/₈"W x 9¹/₄"H x 1"D.
- For easy mobility, most models come complete with 2" casters, two with locking brake.
- Ships via UPS.



LD3



LD4

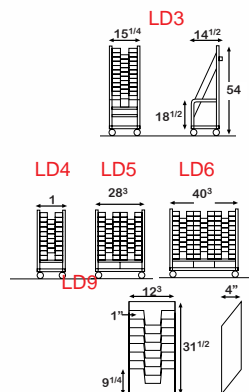

LD5



LD6



LD9

LD3 • 15 ¹ / ₄ "W x 14 ¹ / ₂ "D x 54"H • 23 Lbs. • 12 pocket mobile literature holder	\$281
LD4 • 14 ¹ / ₂ "W x 12"D x 34 ¹ / ₂ "H • 16 Lbs. • 8 pocket mobile literature holder	\$199
LD5 • 28 ³ / ₄ "W x 12"D x 34 ¹ / ₂ "H • 22 Lbs. • 16 pocket mobile literature holder	\$302
LD6 • 40 ³ / ₄ "W x 12"D x 34 ¹ / ₂ "H • 27 Lbs. • 24 pocket mobile literature holder	\$335
LD9 • 12 ⁵ / ₈ "W x 4"D x 31 ¹ / ₂ "H • 14 Lbs. • 8 pocket partition style literature rack	\$134

LH Series

LH models feature:

- Available as wall mounts or desktop application.
- Clear acrylic pockets.
- Standard pocket size of 8⁷/₈"W x 11³/₄"H x 3"D, except where noted.
- Hardware for mounting included with units.
- Ships via UPS.



LH3H3V



LH2H4V



LHCF

LHDTF

LH1 • 11 ¹ / ₈ "W x 12 ¹ / ₄ "H • 4 Lbs. • 1 pocket literature holder
LH2H • 21"W x 12 ¹ / ₄ "H • 6 Lbs. • 2 pocket horizontal literature holder
LH3H • 30 ³ / ₄ "W x 12 ¹ / ₄ "H • 9 Lbs. • 3 pocket horizontal literature holder
LH3V • 11 ¹ / ₈ "W x 36 ³ / ₄ "H • 10 Lbs. • 3 pocket vertical literature holder
LH2H3V • 21"W x 36 ³ / ₄ "H • 16 Lbs. • 6 pocket literature holder
LH2H4V • 21"W x 49"H • 22 Lbs. • 8 pocket literature holder
LH3H3V • 30"W x 37"H • 24 Lbs. • 9 pocket literature holder
LHCF • 3 ¹ / ₈ "W x 8 ⁷ / ₈ "D x 12 ³ / ₈ "H • 8 Lbs. • 1 pocket desk top literature holder
LHDTF • 9 ¹ / ₂ "W x 9 ¹ / ₂ "D x 16 ³ / ₈ "H • 6 Lbs. • 3 pocket desk top literature holder

LDW8 - Mobile wire literature rack with black powder coat finish. Comes with eight, 1" deep and 14" wide display area. Comes complete with 1" chrome furniture casters. Measures 14"W x 12"D x 49"H. Black color. Wt. 22 lbs.

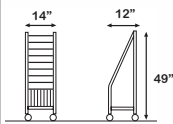

LDW24 - Same as LDW8. 1" deep and 30" wide display area. Measures 30"W x 12"D x 49"H. Black color. Wt. 32 lbs.

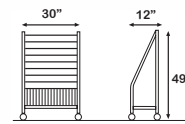

LDW8 • 14"W x 12"D x 49"H • 22 Lbs.

LDW24 • 30"W x 12"D x 49"H • 32 Lbs.

Storage Systems

Library Book and Video Trucks

- Heavy gauge steel construction.
- Quiet and easy rolling anti-shimmy 4" casters.
8" big wheel models also available.
- Most models ship knocked-down for economical, damage free shipping.
- 11" shelf clearance, excluding MT2.
- Double slanted shelves provide a 6 1/2" deep shelf on each side.
- Baked-on powder coat paint finish.

These library book trucks and video tape storage trucks offer a wide range of color and style.

Colorize your environment by choosing the color cart and accent stripe that best suits your particular style.

Use the following color codes when ordering:

Book Truck Colors



Putty (no code) Royal Blue (RB) Burgundy (BY) Forest Green (FG) Camel (CM) Silver (SV) Black (BK)
 New! New!

Accent Stripe Colors



Walnut (W) Silver (SV) Royal Blue (RB) Burgundy (BY) Forest Green (FG) Camel (CM)

The following examples use black for the book truck color, red for the model number and blue for the accent stripe color (if any):



RBMT222RB



BYMT122BY



BKMT222W

New Colors!



RBMT22



MT2



MT3

New Color!



SVMT122SV



RBMTB22RB

Big wheel available for any model. Add "B" to the model number. Ex: MTB12

MT2 • 32"W x 24"D x 60"H • Two slanted shelves. Provides 9½" deep shelves. Putty color only. • 33 Lbs.
MT3 • 32"W x 24"D x 60"H • Big wheel book caddie. Three single slanted shelves provide 7½" deep shelves. Putty only. • 33 Lbs.
MT11 • 28¾"W x 17"D x 30¾"H • Two flat shelf utility truck. • 45 Lbs.
MT12 • 28¾"W x 17"D x 30¾"H • Two 6⅞" slanted shelves and one flat shelf truck. • 45 Lbs.
MT22 • 28¾"W x 17"D x 30¾"H • Four 6⅞" slanted shelves truck. • 45 Lbs.
MT111 • 28¾"W x 17"D x 41"H • Three flat shelf utility truck. • 62 Lbs.
MT112 • 28¾"W x 17"D x 41"H • Two 6⅞" deep slanted and two flat shelf truck. • 62 Lbs.
MT122 • 28¾"W x 17"D x 41"H • Four 6⅞" deep slanted and one flat shelf truck. • 62 Lbs.
MT222 • 28¾"W x 17"D x 41"H • Six 6⅞" deep slanted truck. • 62 Lbs.

Video Trucks



VT2 • 32"W x 24"D x 60"H • Two slanted shelves. Provides 9½" deep shelves. Putty color only. • 33 Lbs.
VT22 • 28¾"W x 17"D x 30¾"H • Four 6⅞" slanted shelves truck. • 45 Lbs.
VT222 • 28¾"W x 17"D x 41"H • Six 6⅞" deep slanted truck. • 62 Lbs.
B • 8" big wheels added to any book or video truck • 10 Lbs.

Index

AOHT1826	57	GNTC11BK	53	LE32P	69	LEM32T	23	LLTS24	32	LPLDUOE	72
ATC232	52	HL13	49	LE33	70	LEM32TWR	24	LLTSE	32	LPLDUOEBW	72
ATC332	52	IBC4	50	LE34	67	LEM32TWRK	24	LMA	33	LPT27	69
ATV56	60	IBC5	50	LE34C	67	LEM32TWRKPS	24	LMC	19	LPT40	69
LEB33	70	IBCFA	51	LE40	68	LEM32TWRT	24	LMC2	19	LPT42	51
ATV56B	60	IEP	51	LE40C	68	LEM32TWRTK	24	LMMCPU	33	LPT44	51
ATV56BC	60	IPTS	50, 51	LE40WT	69	LEM332KB	22	LMMW48	33	LPT48	69
ATV56C	60	ISB	50, 51	LE41	69	LEM332KBC	22	LP26	72	LPT54	69
ATV56KB4	19	ISD	51	LE42	67	LEM58	26	LP26BW	72	LPTBW	69
ATW48CEUL	61	ITB	50, 51	LE42C	67	LEMPF	26	LP26C	72	LRS	66
ATW48EUL	61	JCB30	49	LE42PC	18	LEMPS	26	LP26CBW	72	LRS2	66
ATW56	61	JCB40	49	LE44	70	LEMRO	21, 22	LP26CE	72	LSA	66
ATW56C	61	JCB8	49	LE44P	69	LEMS	26	LP26CEBW	72	LSAK	66
AV26	60	L100	75	LE48	68	LEMSDUO	26	LP26E	72	LSAP	66
AV26B	60	L100S2	47	LE48C	68	LEMSS	26	LP26EBW	72	LSB	66
AV34	60	L100S3	47	LE48WT	69	LEMST	26	LP27	73	LSC25WMT	20
AV34B	60	L150	75	LE50C	71	LEPS3	24	LP27BW	73	LSC50WMT	20
AV42	60	L200	75	LE54	68	LES	66	LP27C	73	LSCW60	20
AV42B	60	L220	74	LE54C	68	LEVC34	70	LP27CE	73	LSGS	66
AVJ42	60	L240	74	LE54WT	69	LEVC42	70	LP27CEBW	73	LSK	66
AVJ422KB4	19	L250	75	LE554	33	LEVC45	70	LP27E	73	LSO	66
AVJ42B	60	L270	74	LE554TO	33	LEW26	22	LP27EBW	73	LSPM	7
AVJ42BC	60	L300	75	LE56LC	71	LEW28	21	LP34	72	LSS	66
AVJ42C	60	L340	74	LE58	26	LEW29C	21	LP34BW	72	LSS2	66
AVJ42CKD	61	LACT2030	28	LE60	70	LEW32	21	LP34C	72	LT34	17
AVJ42KB	20	LAMC2936	17	LE65C	71	LEW32TWR	21	LP34CBW	72	LT342S	17
AVJ42KBC	20	LAMC3037	17	LEB26	67	LEW35	21	LP34CE	72	LT34PC	18
AVJ42KBCDL	19	LBW	66	LEB27C	68	LEW40C	21	LP34CEBW	72	LT45	17
AVJ42KD	61	LCD20	36	LEB34	67	LEWKB	21, 22	LP34E	72	LT45C	17
AVJCPU	20	LCDWR	66	LEB34C	67	LFT71	34	LP34EBW	72	LT45CLL	17
AVJOH	57	LCK	66	LEB40	68	LH1	79	LP40	73	LT45LL	17
AVJOH48	57	LCKU1A	29	LEB40C	68	LH2H	79	LP40BW	73	LT45PC	18
AVJOH48M25	34	LCT15	30	LEB42	67	LH2H3V	79	LP40C	73	LTE1	12
AVJOH48M5	34	LCT2	29	LEB42C	67	LH2H4V	79	LP40CE	73	LTE10	13
AVJOH48MM	34	LCT26	29	LEB44	70	LH3H	79	LP40CEBW	73	LTE11	13
AVJOH48MM2	34	LCT29	31	LEB48	68	LH3H3V	79	LP40E	73	LTE12	13
AVJOH48T	57	LCT43	30	LEB48C	68	LH3V	79	LP40EBW	73	LTE1PA	12
BC45	50	LCT5A	29	LEB50C	71	LHB	66	LP42	72	LTE2	12
BC55	50	LCT6	29	LEB54	68	LHCF	79	LP42BW	72	LTE35	12
BCB45	50	LCT6B	29	LEB54C	68	LHDAWS	28	LP42C	72	LTE4	12
BCB55	50	LCTCH	29	LEB60	70	LHDTF	79	LP42CBW	72	LTE6	12
BUSTC111PR	53	LCTE	29	LEB65C	71	LICW3018	48	LP42CE	72	LTE7	14
BUSTC121GY	53	LCTL1830	27	LEB66C	71	LICW4218	48	LP42CEBW	72	LTE8	14
C200	75	LCTL2428	27	LEBDUO	67	LICWES	48	LP42E	72	LTE9	13
C300	75	LCTL2435	27	LEBDUOC	67	LICWT2918	47	LP42EBW	72	LTEV	13
C5	54, 66	LCTL2452	27	LEDUO	67	LICWT3014	47	LP48	73	LTEV2	13
C51	54	LCTL29	27	LEDUOC	67	LIW3639	47	LP48BW	73	LTEVD	13
CS36	34	LCTSB	29	LEES	66	LIW4239	47	LP48C	73	LTVS	14
CS36S	34	LCW120	31	LEF34C	71	LIWBR	48	LP48E	73	LUD2	10
CSC47	32	LCW120D	31	LEF40C	71	LIWCD	48	LP48EBW	73	LUD3	10
CSC57	32	LCW120DB	31	LEF42C	71	LIWPS	48	LP54	73	LUFMPRC	11
CSC58KD	32	LCW180	31	LEF56C	71	LIWRE	48	LP54BW	73	LUFMPRG	11
CSC61	32	LCW180B	31	LLEBDUO	68	LIWRO	48	LP54C	73	LUMA	10
DVC	62	LCW2948	28	LLEBDUOC	68	LIWSS	48	LP54E	73	LUPM	10
DW	66	LDDFS68	11	LLELDUO	68	LIWUB	48	LP54EBW	73	LUPMC	10
EMCA48	35	LDDFS80	11	LLELDUOC	68	LKCP10	36	LPCSA	54	LUPMSS	11
EMCA48T	35	LDW24	79	LEM32	23	LKCP11	36	LPD300	49	LUPMW	10
EMCPU	72	LDW8	79	LEM32FT	25	LKCP12	36	LPDUO	72	LUPMWX	11
EMS	23, 66	LE26	67	LEM32FTO	25	LKCP14	36	LPDUOBW	72	LVC	62
ESE	22, 66	LE26C	67	LEM32K	23	LKCP15	36	LPDUOC	72	LVDH	7
FR8 21, 55, 65, 66, 69		LE27	68	LEM32P	25	LLMSC	15	LPDUOCBW	72	LW	66
FRTVW48281	62	LE27C	68	LEM32P5	25	LLMSC2537	15	LPDUOCE	72	LWT970	48
GNSTC111GN	53	LE29	69	LEM32PT	25	LLMSD	15	LPDUOCEBW	72	LX50	76
				LEM32PT5	25	LLMSW	15	LPDUOE	72	LX9128	35, 76
				LEM32S	24	LLMSW2537	15	LPDUOEBW	72	LXAPL	7
						LLMSWB	15	LPE	69	LXCTM1	11
						LLPMS	7	LPLDUO	72	LXCTM2	11
						LLSW100	15	LPLDUOBW	72	LXPBL	7

LXPSD	.11	PTC21	.55	TLMD2	.21, 22
LXSCS	.7	RDSTC111YW	.53	TLMS	.39
LXUA1330L	.6	RDSTC221BU	.53	TLOH29	.40
LXUF1330L	.6	RE20	.66	TLOH38	.40
LXUF2637	.6	S24	.40	TLPC	.39
LXUF3760	.6	SC14	.50	TLSB	.37
LXUT1330L	.6	SCB30	.50	TRVC	.66
LXUT2637	.6	SCB30C	.50	TV40RT	.64
LXUT3760	.6	SP100	.14	TVES54C	.64
MB3624	.56	SP8	21, 55, 65, 69	TVP32	.65
MB4836	.56	SPD140	.49	TVP32LT	.65
MB6036	.56	SST2L	.46	TVP44	.65
MB7240	.56	SST2S	.46	TVP44C	.65
MMC56	.34	STBW/LTBW	.54	TVP44LT	.65
MRC51	.46	STC11	.54	TVP44LTC	.65
MRC52	.46	STC111	.54	TVP44SP	.65
MRCW1	.46	STC1111	.54	TVS34	.64
MRCW2	.46	STC112	.54	TVS34C	.64
MSB42	.49	STC12	.54	TVS36	.64
MSC37	.20	STC121	.54	TVS44	.64
MT11	.81	STC122	.54	TVS44C	.64
MT111	.81	STC21	.54	TVS48	.64
MT112	.81	STC211	.54	TVS48C	.64
MT12	.81	STC2111	.54	TVS54	.64
MT122	.80	STC212	.54	TVS54C	.64
MT2	.80	STC221	.54	TVS554	.64
MT22	.80	SW	.66	TVW42	.63
MT222	.80, 81	T5	.66	TVW44	.63
MT3	.80	TC11	.55	TVW44C	.62
MTC30DL/N	.51	TC111	.55	TVW44CEUL	.63
MTC30DLL/N	.51	TC1111	.55	TVW44EUL	.63
MTC40DLL/N	.51	TC112	.55	TVW44i	.62
MTC40DN	.51	TC12	.55	TVW48	.63
MTCL	.51	TC121	.55	TVW48C	.62
MTCLL	.51	TC122	.55	TVW48CEUL	.63
MTO	.66	TC21	.55	TVW48EUL	.63
MWC54	.33	TC211	.55	TVW48i	.62
OEPS26	.23	TC2111	.55	TVW54	.63
OEPS32	.23	TC212	.55	TVW54C	.62
OHS32	.58	TC221	.55	TVW54i	.62
OHS42	.58	TL16PS	.39	TVW554	.63
OHT20	.59	TL1830	.40	TVW554C	.63
OHT29	.57	TL1830MD	.40	TVWE54C	.63
OHT292S	.57	TL1837	.39	TWP46	.63
OHT30	.59	TL2428YY	.38	TWP46P	.63
OHT32	.58	TL2435RR	.38	UCC1	.30
OHT39	.57	TL2452	.39	VC	.62
OHT40	.59	TL2453	.39	VP34B	.70
OHT40C	.59	TL2454	.39	VP40B	.70
OHT42	.58	TL2458	.39	VPC37B	.70
OHT42C	.58	TL24P4	.39	VPC40B	.70
OHT42PS	.58	TL28	.38	VT2	.81
OHT42PSC	.58	TL3628	.38	VT22	.81
OHT50	.59	TL3635	.38	VT222	.81
OHT50C	.59	TL36W	.38	WT	.69
P504P	.75	TL37TV	.40		
P8	.21, 55	TL4	.37		
PC42KB	.18	TL4828	.38		
PC44KBC	.18	TL4828MM	.40		
PC51KB	.18	TL4835	.38		
PCS24	.30	TL4835MM	.40		
PPD200	.49	TL4850	.37		
PS2633	.56	TL48W	.38		
PS3144	.56	TL6028	.37		
PS3800	.56	TL6035	.37		
PS3945	.16	TL6050	.37		
PS57OKD	.32	TLKB	.37		
PTC111	.55	TLMD	.21, 22		



LUXOR

2008-2009 • Over 30 New Products • 2008-2009 • Over 30 New Products •

