



Instructions for All In One Photocell Feeder

THANK YOU for your purchase of the All-In-One Photocell Feeder. Please read this sheet before operating the unit. If you should have any questions about this product or any other Moultrie product, please contact us using the information on the back of this sheet. To help us to better serve you, please complete and mail the enclosed Registration Card.

IA PURCHASED WITH EXPANDABLE BUCKET

Expand Feeder by pulling firmly on both ends until sections click and lock permanently into place.

If sections do not lock into place, confirm that the internal alignment ribs are in the correct position. Remove the lid and look down inside bucket. Verify that the vertical ribs along the side are aligned with the small notches located in the top of each section.

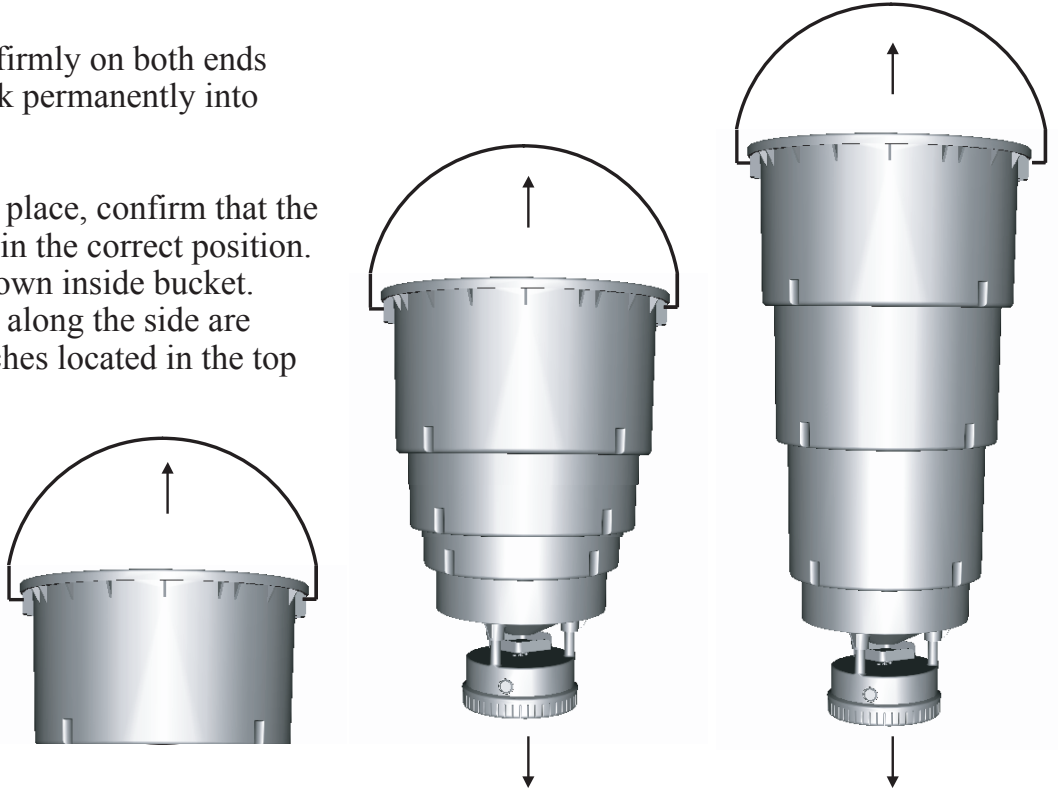

IB PURCHASED WITHOUT EXPANDABLE BUCKET

CAUTION: WEAR EYE PROTECTION

The All-In-One Feeder will mount to any drum or bucket.

- 1** Turn bucket over, measure and mark the center of the bottom.
- 2** Center the provided Template on the bottom of the bucket and secure with tape. Drill three 5/16" Feeder Leg Holes.
- 3** Using a hole saw, drill a 2-1/4" hole in the center of the bottom of your bucket.
- 4** Rotate the Mounting Legs outward on the Feeder Mounting Bracket. Attach Feeder to Bucket using three provided 1/4"x 1/2" screws, washers, and nuts as shown.

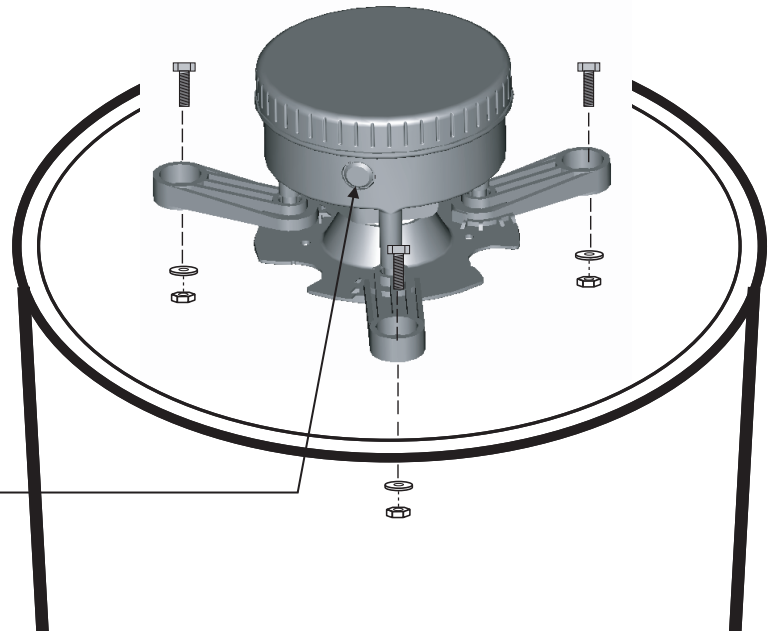
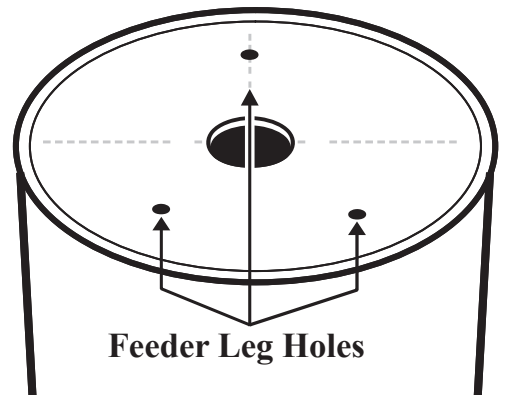

Solar Panel Receptacle
The Moultrie Solar Panel upgrade (MFH-DSP) will greatly extend battery life and may be purchased at a Moultrie Distributor or by calling Moultrie using the telephone number on back side of this sheet.

II INSTALLING BATTERIES AND TESTING

CAUTION: WEAR EYE PROTECTION

1 INSTALLING BATTERIES: To install the batteries or adjust the feed settings, remove the bottom of the feeder by rotating it counter clockwise as shown. Install four (4) AA Alkaline or Moultrie rechargeable batteries with the negative side of the battery going to the battery holder spring clip. Replace bottom by rotating clockwise until secure.

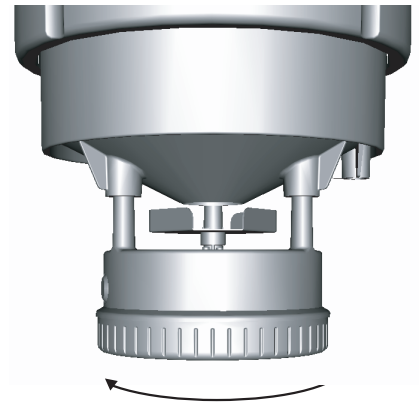

Rotate Counter Clockwise to Open

2 TEST FEEDER: To test Feeder, press and release the small push-button switch located on the circuit board. **GET AWAY FROM FEEDER AFTER PRESSING SWITCH.** The Feeder will run one test cycle three seconds after the small push-button switch is pressed.

III PROGRAMMING FEEDER

Your feeder uses a light level detector to assist in determining when to distribute feed. The feeder distributes two times per day - once shortly after daybreak and again in the evening. After a feed distribution cycle, the light detector is disabled for 7 hours to prevent false readings that could occur due to cloud cover or lightning.

1 Locate the **Switch Panel** inside Feeder.

	= 4 Seconds	DISPENSES APPROX.	0.8 Pounds of Feed
	= 6 Seconds	DISPENSES APPROX.	1.0 Pound of Feed
	= 8 Seconds	DISPENSES APPROX.	1.3 Pounds of Feed
	= 10 Seconds	DISPENSES APPROX.	1.6 Pounds of Feed
	= 12 Seconds	DISPENSES APPROX.	1.9 Pounds of Feed
	= 14 Seconds	DISPENSES APPROX.	2.2 Pounds of Feed
	= 16 Seconds	DISPENSES APPROX.	2.4 Pounds of Feed
	=	Feed approximately 30 minutes before dark.	
	=	Feed just before dark	

2 You can regulate the amount of feed dispensed by setting the switches to the desired **Run Time** as shown in chart on right. Amount of feed distributed is approximate and will vary.

3 The evening feed time is modifiable as shown in chart on right.

NOTE: This equipment has been tested and found to comply with the limits of Part 15 of the FCC Rules. These limits are designed to provide reasonable protection against harmful interference in a residential installation. This equipment generates, uses and can radiate radio frequency energy and, if not installed and used in accordance with the instructions, may cause harmful interference to radio communications. However, there is no guarantee that interference will not occur in a particular installation. If this equipment does cause harmful interference to radio or television reception, which can be determined by turning the equipment off and on, the user is encouraged to try to correct the interference by one or more of the following measures:

- Reorient or relocate the receiving antenna.
- Increase the separation between the equipment and receiver.
- Connect the equipment into an outlet on a circuit different from that to which the receiver is connected.
- Consult the dealer or an experienced radio/TV technician for help.



Our Service Department will gladly answer any questions you have. Call 205-664-6700 or 800-653-3334, Monday - Friday, 8:00 AM to 5:00 PM CST. www.moultriefeeders.com