



Instructions for EZ Fill Feeder

THANK YOU for your purchase of the EZ Fill Feeder, a top quality Moultrie product. Please read this sheet before assembling the product. If you should have any questions about this or any other Moultrie product, please contact us using the information on the reverse side of this sheet. To help us to better serve you, please complete and mail the attached Registration Card.

I ASSEMBLING HOPPER

1 Attach provided **Hinge** to **Hopper Top Section** using two 1" long bolts. Inside the **Hopper**, place a washer and lock-nut on each screw. Place **Hopper Lid** on **Hopper Top** and thread **Hinge Pin** through hole. Slide **Cotter Pin** through hole in **Hinge Pin** and spread legs as shown.

2 Attach the **Strike** to the **Hopper Lid** and **Catch** to the **Hopper Top** using four provided 1/2" long screws as shown. Inside the **Hopper**, place a washer and lock-nut on each screw.

3 Place **Hopper Bottom Section** on **Hopper Top Section** as shown. For each of the nine holes, insert provided 1" long bolt through a washer, the **Hopper Junction Ring**, another washer, lock-washer, and into the nut as shown. Use a wrench to tighten each of the nuts.

4 Slide the three provided **Square Leg Receivers** into the **Hopper** as shown.

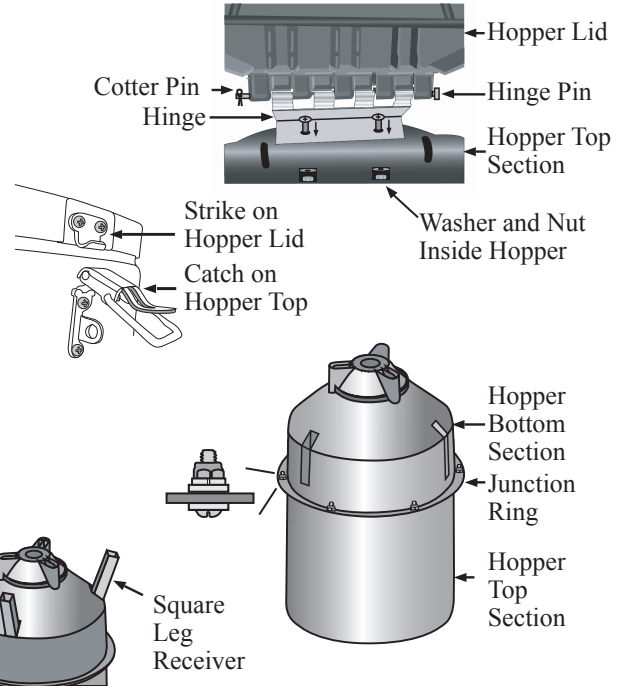

II MOUNTING FUNNEL, FEEDER, AND GUARD

1 Place **Funnel** over the bottom opening and secure to the **Hopper** using the two provided 3/4" long screws as shown.

2 The components of the Feeder are wire-tied together for your convenience. The **Spacer** goes against the **Hopper** followed by the **Feeder**. Secure items to Hopper using provided 1.5" long screws and washer as shown.

3 Route **Wire** through **Hole** in **Hopper** and secure **Grommet** by pressing firmly as shown.

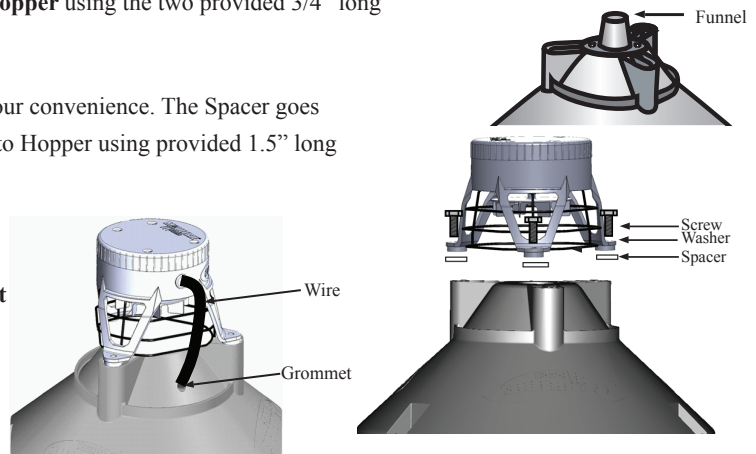

III STANDING UP FEEDER

Assemble three **Leg Poles** using two **Leg Sections** each as shown. Align the spring clip in the **Leg Section** with a hole in the other **Leg Section**. Attach provided **Feeder Feet** to bottom of **Leg Poles** as shown. Lay Hopper on side. Install a **Leg Pole** on the inside of each of the **Square Leg Receivers**. With two **Leg Poles** against the ground as shown, carefully stand up the **Feeder** assembly.

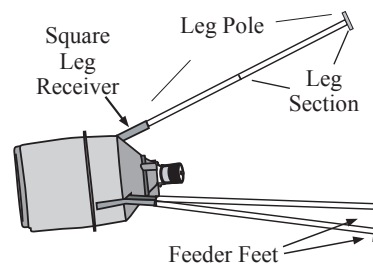

DO NOT EXCEED 200 POUNDS OF FEED

IV INSTALLING CONTROL BOX AND BATTERY

CAUTION: WEAR EYE PROTECTION

- 1 Hold Control Box near holes on the side of the Hopper and route wire through 3/4" hole. Align threaded studs on back of Control Box with holes in side of Hopper. From inside Hopper, secure Control Box to Hopper using provided four nuts and washers. Reach inside Hopper and plug lower unit wire into Control Box wire connector. Attach wire to inside wall of hopper using provided adhesive-backed wire straps.
- 2 Open Control Box door and install a 6-Volt Alkaline (ex. Energizer™) or Moultrie rechargeable battery by attaching the Red Alligator Clip to the positive terminal (+) and the Black Alligator Clip to the negative (-) terminal.



Feeder is Solar Panel Ready

The Moultrie Solar Panel upgrade (MFH-DSP) will greatly extend battery life and may be purchased at a Moultrie Distributor or by calling Moultrie using the telephone number below.

V CONFIGURING AND TESTING FEEDER

Your Feeder will feed up to six times per day and has been factory set to feed at 7:00am and 6:00pm for six seconds. To change the factory settings or add additional feed times, follow the instructions below. The Battery Level is displayed every seven seconds. It is recommended that the battery be replaced when the %BATTERY reading is 25% or below.

SET TIME OF DAY: Press the UP or DOWN button until the correct time of day appears. Press and release button to single-step through the minutes or hold down to advance quickly. The feeder will not run while buttons are being pressed and waits 10 seconds from the last button press before it is activated. The feeder is activated when the display alternates between the CURRENT TIME and %BATTERY.

SET FEED TIMES: Press the SET button until the correct Timer Number appears in the upper right hand corner as shown. Press the UP or DOWN button to set the Feed Time.

SET RUN DURATION: Press the SET button again to set the RUN-TIME SECONDS which can range from zero to twenty seconds. Adjust RUN-TIME SECONDS using the chart below. Set the RUN-TIME SECONDS to zero to disable the specific timer.

RUN TIME (sec.)	4	6	8	10	12	14	16	18	20
Approx. feed dispensed (lbs.)	.75	1	1.5	2	2.5	3	3.5	4	4.5

TEST FEEDER: PRESS AND HOLD the SET button while the RUN-TIME SECONDS are displayed. Release the button and get away from the feeder when the message "TESTING GET AWAY" appears on the display.

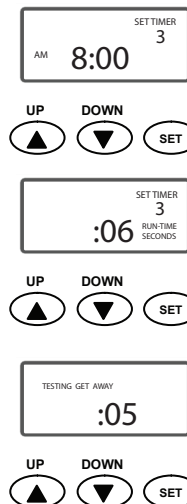

NOTE: This equipment has been tested and found to comply with the limits of Part 15 of the FCC Rules. These limits are designed to provide reasonable protection against harmful interference in a residential installation. This equipment generates, uses and can radiate radio frequency energy and, if not installed and used in accordance with the instructions, may cause harmful interference to radio communications. However, there is no guarantee that interference will not occur in a particular installation. If this equipment does cause harmful interference to radio or television reception, which can be determined by turning the equipment off and on, the user is encouraged to try to correct the interference by one or more of the following measures:

- Reorient or relocate the receiving antenna.
- Increase the separation between the equipment and receiver.
- Connect the equipment into an outlet on a circuit different from that to which the receiver is connected.
- Consult the dealer or an experienced radio/TV technician for help.



Our Service Department will gladly answer any questions you have. Call 205-664-6700 or 800-653-3334, Monday - Friday, 8:00 AM to 5:00 PM CST. www.moultriefeeders.com

07232010R7 / MFH-EZF30T

Warranty Registration

Thank you for purchasing Moultrie Products. To help us serve you better, please fill out and return below information to register your warranty. Register online www.moultriefeeders.com or return to: Moultrie 150 Industrial Road, Alabaster, AL 35007

Name: _____ Phone Number: _____

Address: _____

City, State, Zip: _____

Email Address: _____

Which model did you purchase? _____

Dealer and town purchased: _____ Date purchased: _____

Comments: _____

Check this box if you wish to receive future promotional offers from Moultrie via e-mail and U.S. mail