



Instructions for ATV Spreader Electric Feedgate

THANK YOU for your purchase of the ATV Spreader, a top quality Moultrie product. Please read this sheet before assembling the unit. If you should have any questions about this or any other Moultrie product, please contact us using the information on the reverse side of this sheet. To help us to better serve you, please complete and mail the enclosed Warranty Card.

I MOUNTING BRACKET TO ATV RACK

Secure provided **Mounting Bracket** to the rack of your ATV using provided **U-Bolts**, washers, and nuts. Rotate **Mounting Bracket Legs** to a position that will allow a **U-Bolt** to be connected around each end of the **Mounting Bracket Leg** as shown.

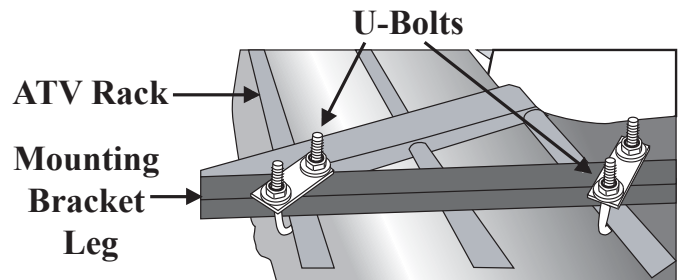

II ATTACHING SPREADER AND STRAP

1 Slide the square hitch on the **ATV Spreader** frame into the mating receiver on the **Mounting Bracket**

2 Thread provided **Ratchet Strap** through eyebolt on back of Spreader Frame. Place **Ratchet Strap** S-hooks around the front of your ATV rack (close to seat). Adjust tension on **Ratchet Strap** until firm.

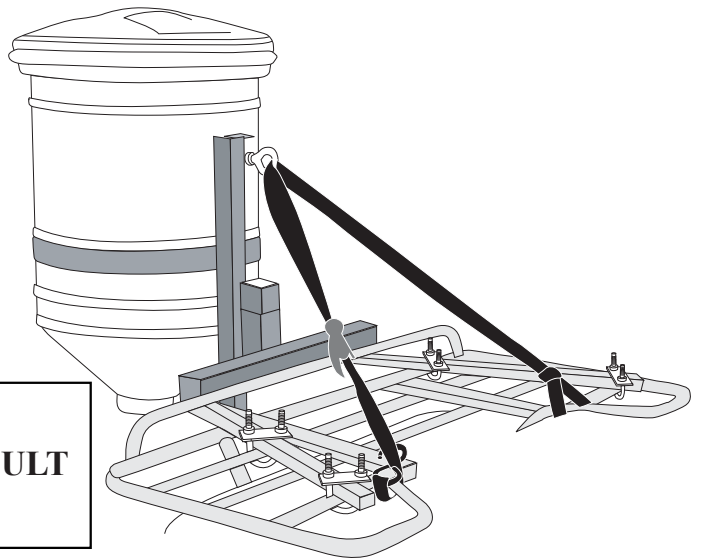

FAILURE TO PROPERLY CONNECT AND MONITOR THE RATCHET STRAP MAY RESULT IN DAMAGE TO THE ATV OR SPREADER

III CONNECTING HAND CONTROL

1 Plug the white connector that is on the end of the long wire exiting the **Hand Control** into the mating connector on the **Feedgate**.

2 Connect the black connector that is on the end of the long wire exiting the **Hand Control** into the mating connector on the **Spin Motor**.

3 Plug the lighter plug into your ATV's accessory receptacle.

IV ADDING MATERIAL AND ADJUSTING STRAP

1 Add desired material such as feed, fertilizer, seed, etc. to hopper and attach lid.

2 With the material loaded, verify that **Ratchet Strap** is tight enough to hold the hopper body perpendicular to the ATV rack. Tighten as necessary.

V

CALIBRATING AND OPERATING UNIT



CAUTION: WEAR EYE PROTECTION

1 CALIBRATE: To assure proper operation, the ATV Spreader should be calibrated each time it is first connected to the ATV. Calibration should be performed with the ATV running.

To calibrate, hold the OFF button and press the ON button momentarily. While in calibration mode, the lights will flash rapidly. Once calibration is complete, the lights will go out and the gate will close. The unit is now ready for operation.

2 SET DISPENSING AMOUNT: The “1” position is the minimum amount and the “6” position is the maximum amount of material flow. Press the MORE or LESS button to achieve the desired opening amount. The Material Flow amount light flashes when the unit is not running and is on solid when the unit is running.

3 SPREAD MATERIAL: To spread material, press the ON button while moving at a constant rate. While ON, the MORE or LESS buttons may be pressed to achieve the desired material flow rate. To stop the unit, press the OFF button.

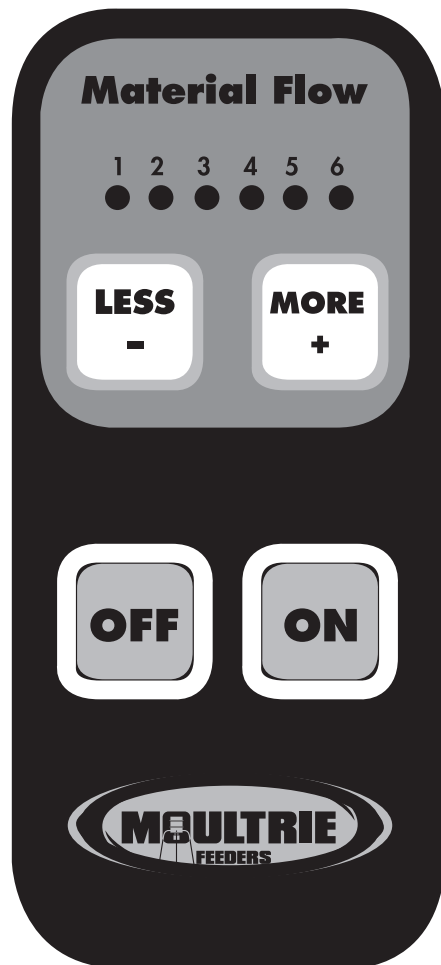

VI

CLEANING AND STORING UNIT

NOTE: FERTILIZER IS EXTREMELY CORROSIVE. After spreading material, completely wash and dry ATV Spreader; however, water should not get on the feedgate. A light coat of oil on all metal parts and the motor will help prevent rusting and corrosion.

To clean the feedgate, remove the two screws from the bottom and slide the cover forward until it drops off. Use a soft bristle brush to remove any dust from the gear or on the felt.

TIPS & POINTERS

1: (Q) Can I leave the ATV Spreader connected to my ATV when it is not in use? (A) Yes, however to reduce the possibility of damage to the spreader, it is highly recommended that the hopper is empty.

2: (Q) Should I operate my ATV differently when the ATV Spreader is loaded?
(A) Yes, the additional weight in the rear of the ATV will cause the front-end of the ATV to be lighter. Care must be taken when traveling up and down hills due to this shift in weight.

3: (Q) Can I get replacement parts for my ATV Spreader? (A) Yes, you may purchase the following Moultrie replacement parts.

- Bolt Pack** MFHP81564
- Motor** MFHP81747
- Wire Harness** MFHP81744
- Spin Plate** MFHP81145
- Mounting Bracket.....** MFHP60084

This equipment has been tested and found to comply with the limits for a Class B digital device pursuant to Part 15 of the FCC rules. These limits are designed to provide reasonable protection against harmful interference in a residential installation. This equipment generates, uses and can radiate radio frequency energy and, if not installed and used in accordance with the instructions, may cause harmful interference to radio communications. However, there is no guarantee that interference will not occur in a particular installation. If this equipment does cause harmful interference to radio or television reception, which can be determined by turning the equipment off and on, the user is encouraged to correct the interference by one or more of the following measures: • Increase the separation between the equipment and the receiver • Reorient or relocate the receiving antenna



Our Service Department will gladly answer any questions you have. Call 205-664-6700 or 800-653-3334, Monday - Friday, 8:00 AM to 5:00 PM CST. www.moultriefeeders.com