



Instructions for Pro Magnum Feeder Kit

THANK YOU for your purchase of the Pro Magnum Feeder Kit. Please read this sheet before operating the unit. If you should have any questions about this product or any other Moultrie product, please contact us using the information on the back of this sheet. To help us to better serve you, please complete and mail the enclosed Warranty Card.

I ASSEMBLING AND MOUNTING

1 Attach provided **Hinge** to **Hopper Top Section** using two 1" long bolts. Inside the **Hopper**, place a washer and lock-nut on each screw. Place **Hopper Lid** on **Hopper Top** and thread **Hinge Pin** through hole. Slide **Cotter Pin** through hole in **Hinge Pin** and spread legs as shown.

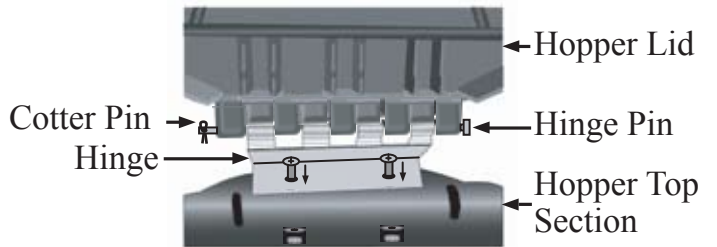

2 Attach the **Strike** to the **Hopper Lid** and **Catch** to the **Hopper Top** using four provided 1/2" long screws as shown. Inside the **Hopper**, place a washer and lock-nut on each screw.



3 Place **Hopper Bottom Section** on **Hopper Top Section** as shown. For each of the nine holes, insert provided 1" long bolt through a washer, the **Hopper Junction Ring**, another washer, lock-washer, and into the nut as shown. Use a wrench to tighten each of the nuts.

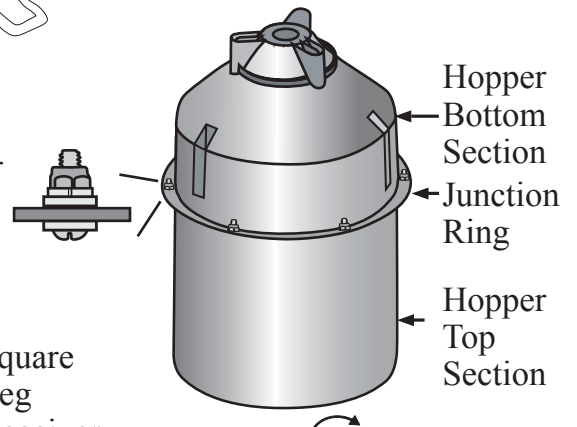

4 Slide the three provided **Square Leg Receivers** into the **Hopper** as shown.

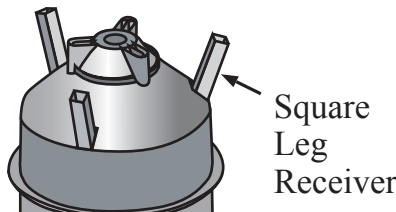

5 Turn provided **Wingnut** onto the **Dual Threaded Stud** until it reaches the bottom of the threads. Place the pointed side of **Dual Threaded Stud** into hole in **Plastic Drum**. Turn the **Dual Threaded Stud** into **Plastic Drum** until **Nut** is flush with plastic surface. Remove **Wingnut**. Repeat for the remaining two holes.

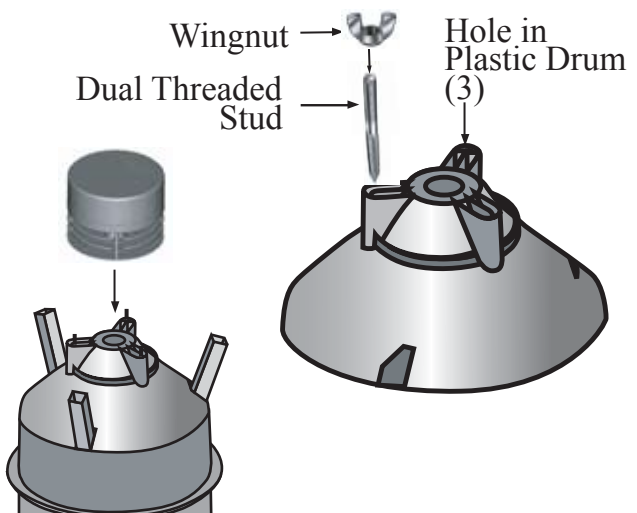

6 Place **Feeder** onto threaded studs and secure to **Hopper** using the three provided **Wingnuts**.

II STANDING UP FEEDER

Lay Hopper on side. Using three **Leg Sections**, install a **Leg Pole** on the inside of each of the **Square Leg Receivers**. With two **Leg Poles** against the ground as shown, carefully stand up the **Feeder** assembly.

NOTE: Distance between legs at ground should not exceed 75 inches. To prevent tipping, the **Feeder** must be placed on level ground.

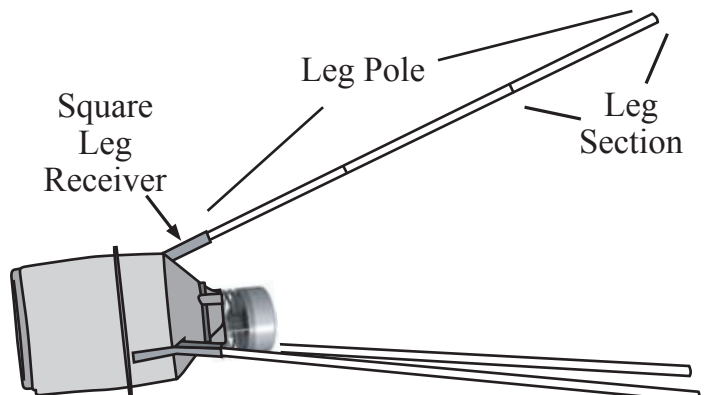

DO NOT EXCEED 200 POUNDS OF FEED

III INSTALLING BATTERIES



CAUTION: WEAR EYE PROTECTION

Remove bottom and install one or two 6-Volt Alkaline (ex. Energizer™) or Moultrie rechargeable batteries by attaching the Red Alligator Clip to the positive terminal (+) and the Black Alligator Clip to the negative (-) terminal.

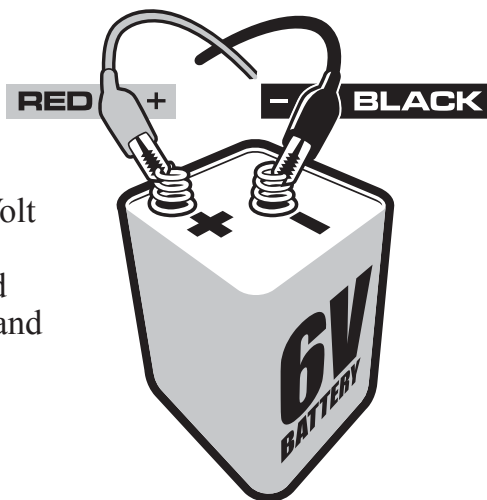

IV CONFIGURING AND TESTING FEEDER

Your Pro Magnum will feed up to six times per day and has been factory set to feed at 7:00am and 6:00pm for six seconds. To change the factory settings or add additional feed times, follow the instructions below. The Battery Level is displayed every seven seconds. It is recommended that the battery be replaced when the %BATTERY reading is 25% or below.

SET TIME OF DAY: Press the UP or DOWN button until the correct time of day appears. Press and release button to single-step through the minutes or hold down to advance quickly. The feeder will not run while buttons are being pressed and waits 10 seconds from the last button press before it is activated. The feeder is activated when the display alternates between the CURRENT TIME and %BATTERY.

SET FEED TIMES: Press the SET button until the correct Timer Number appears in the upper right hand corner as shown. Press the UP or DOWN button to set the Feed Time.

SET RUN DURATION: Press the SET button again to set the RUN-TIME SECONDS which can range from zero to twenty seconds. Adjust RUN-TIME SECONDS using the chart below. Set the RUN-TIME SECONDS to zero to disable the feed time.

RUN-TIME SECONDS	4	6	8	10	12	14	16	18
Approx. feed dispensed (lbs.)	.75	1	1.5	2	2.5	3	3.5	4

TEST TIMER: To test the Timer, PRESS AND HOLD the SET button while the RUN-TIME SECONDS are displayed. Release the button and get away from the feeder when the message “TESTING GET AWAY” appears on the display. The display will countdown five seconds before activating the motor for the number of RUN-TIME SECONDS programmed. The test feature is useful for assessing the amount of feed to dispense.

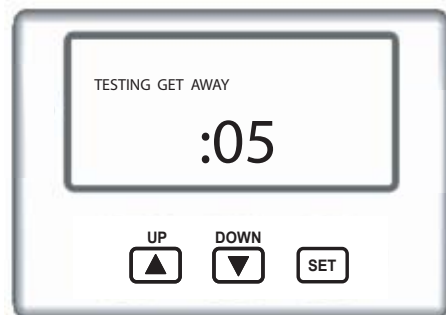
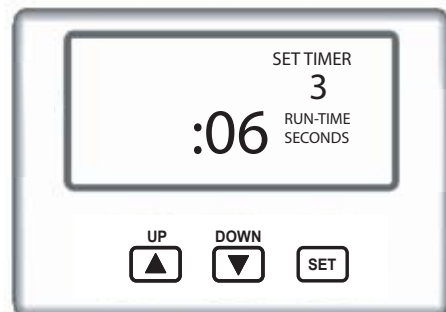
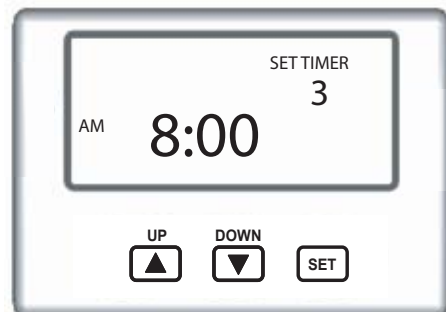

NOTE: This equipment has been tested and found to comply with the limits of Part 15 of the FCC Rules. These limits are designed to provide reasonable protection against harmful interference in a residential installation. This equipment generates, uses and can radiate radio frequency energy and, if not installed and used in accordance with the instructions, may cause harmful interference to radio communications. However, there is no guarantee that interference will not occur in a particular installation. If this equipment does cause harmful interference to radio or television reception, which can be determined by turning the equipment off and on, the user is encouraged to try to correct the interference by one or more of the following measures:

- Reorient or relocate the receiving antenna.
- Increase the separation between the equipment and receiver.
- Connect the equipment into an outlet on a circuit different from that to which the receiver is connected.
- Consult the dealer or an experienced radio/TV technician for help.



Our Service Department will gladly answer any questions you have. Call 205-664-6700 or 800-653-3334, Monday - Friday, 8:00 AM to 5:00 PM CST. www.moultriefeeders.com